

# Технические характеристики VACUTAP® VM®, VM 300, VMS®. Устройство РПН

2332907/06 RU



© Все права принадлежат компании Maschinenfabrik Reinhausen.

Информацию, содержащуюся в данной инструкции, запрещается копировать или передавать третьим лицам без письменного разрешения правообладателя.

Нарушение этого запрета может повлечь обращение в суд с требованием компенсации. Все права в области патентования и регистрации промышленных образцов и товарных знаков защищены.

После выпуска данной инструкции конструкция прибора может быть изменена.

Мы оставляем за собой право изменять технические характеристики и конструкции приборов, а также комплект поставки.

Решающее значение имеет информация, передаваемая при составлении предложений и заказов, а также достигнутые договоренности.

Оригинал данного документа составлен на немецком языке.

# Оглавление

<b>1 Вводная часть</b> .....	<b>5</b>	4.2.5 746223 .....	38
1.1 Обозначения устройств РПН .....	5	4.2.6 746229 .....	39
1.1.1 Пример обозначения устройства РПН .....	5	4.2.7 746220 .....	40
1.1.2 Число ступеней и принципиальная схема .....	5	4.2.8 746219 .....	41
1.2 Исполнения устройства РПН .....	7	4.2.9 746224 .....	42
1.3 Принципиальные схемы .....	7	4.2.10 746226 .....	43
<b>2 Технические характеристики</b> .....	<b>11</b>	4.2.11 10116560 .....	44
2.1 Характеристики устройства РПН .....	11	4.2.12 746230 .....	45
2.2 Допустимые условия окружающей среды .....	14	4.2.13 10117022 .....	47
2.3 Графики мощности ступеней .....	14	4.2.14 765192 .....	48
2.3.1 График мощности ступени для сетевого трансформатора VACUTAP® VM® и VM 300 .....	15	4.2.15 768698 .....	49
2.3.2 График мощности ступени для VACUTAP® VM® и VM 300 при эксплуатации при дуговой электропечи .....	16	4.2.16 769225 .....	50
2.3.3 График мощности ступени для сетевого трансформатора VACUTAP® VMS® III .....	17	4.2.17 769226 .....	51
2.4 Допустимые нагрузки напряжением .....	18	4.2.18 768851 .....	52
2.4.1 Изоляционные промежутки без избирателя с несколькими грубыми ступенями .....	18	4.3 Головка устройства РПН .....	53
2.4.2 Изоляционные промежутки с избирателем с несколькими грубыми ступенями .....	22	4.3.1 893899 .....	54
2.4.3 Возможные схемы .....	24	4.3.2 720026 .....	55
<b>3 Специальные исполнения</b> .....	<b>26</b>	4.3.3 720027 .....	56
3.1 Перемычки для параллельного подключения уровней избирателя .....	26	4.3.4 896762 .....	57
3.2 Комбинация устройств РПН для схемы соединения обмотки «треугольник» .....	26	4.3.5 893896 .....	58
3.3 Устройство РПН VACUTAP® VM III 650 Y...VM I 1503 с избирателем с несколькими грубыми ступенями (макс. пять грубых ступеней) .....	27	4.3.6 895168 .....	59
3.4 Двухфазное устройство РПН VACUTAP® VM II 302/352/502/652 .....	28	4.3.7 766161 .....	60
3.5 Устройство РПН для соединения по схеме «звезда» с разомкнутой нейтралью звезды .....	28	4.4 Масляный бак контактора .....	61
<b>4 Чертежи</b> .....	<b>29</b>	4.4.1 730336 .....	62
4.1 Обзор типов .....	29	4.5 Избиратель .....	63
4.1.1 899740 .....	30	4.5.1 890477 .....	64
4.1.2 10117026 .....	31	4.5.2 898013 .....	65
4.1.3 765835 .....	32	4.5.3 730335 .....	66
4.2 габаритные чертежи; .....	33	4.5.4 723590 .....	67
4.2.1 746221 .....	34	4.5.5 891108 .....	68
4.2.2 746227 .....	35	4.5.6 891110 .....	69
4.2.3 746222 .....	36	4.5.7 891109 .....	70
4.2.4 746228 .....	37	4.5.8 891107 .....	71
		4.5.9 725649 .....	72
		4.5.10 893934 .....	73
		4.5.11 893935 .....	74
		4.5.12 899598 .....	75
		4.5.13 898804 .....	76
		4.5.14 719733 .....	77
		4.5.15 898690 .....	78
		4.5.16 898691 .....	79
		4.5.17 898692 .....	80
		4.5.18 10117025 .....	81
		4.5.19 10117029 .....	82
		4.5.20 10116563 .....	83
		4.5.21 898041 .....	84
		4.5.22 891114 .....	85
		4.5.23 898695 .....	86
		4.5.24 898694 .....	87
		4.5.25 898693 .....	88

4.6 Электрические схемы (примеры) .....	89
4.6.1 SBI_2414658 .....	90
4.6.2 SBI_2414670 .....	91
4.6.3 SBI_2414631 .....	92
4.6.4 SBI_2407535 .....	93
4.6.5 SBI_2414636 .....	94
4.6.6 SBI_6228951 .....	95
4.6.7 SBI_6228952 .....	96



# 1 Вводная часть

Данный технический документ содержит подробную информацию о технических характеристиках изделия. Основную информацию см. в Общей части Технических Данных TD 61.

## 1.1 Обозначения устройств РПН

Устройства РПН каждого типа поставляются в различных исполнениях, которые могут отличаться числом фаз, максимальным расчетным рабочим током, максимальным напряжением для оборудования  $U_m$ , размерной серией избирателя и принципиальной схемой. Поэтому каждое исполнение устройства РПН обозначается в соответствии с этими характеристиками. Таким образом, по обозначению устройства РПН можно однозначно определить его характеристики.

### 1.1.1 Пример обозначения устройства РПН

Устройство РПН VACUTAP® VM III 650 Y-72,5 / C-10 19 1W R.

Обозначение типов	VACUTAP® VM III 650 Y-72,5 / C-10 19 1W R
VACUTAP® VM®	Тип устройства РПН
III	Количество фаз
650	Максимальный расчетный рабочий ток $I_m$ (А), а также количество рабочих секторов (последняя цифра) контактора однофазных устройств РПН
Y	Применение только в нейтрали звезды
72,5	Максимальное напряжение для оборудования $U_m$ (кВ)
C	Размерная серия избирателя
10 19 1W R	Принципиальная схема

Табл. 1: Пример обозначения устройства РПН

### 1.1.2 Число ступеней и принципиальная схема

Избиратель можно подобрать в соответствии с требуемым числом ступеней и схемой регулировочной обмотки. Принципиальные схемы различаются по числу контактов избирателя на один уровень, количеству рабочих положений, количеству средних положений, исполнению предызбирателя и типу привязки потенциала.

Пример: 10 19 1 WR

Обозначение принципиальной схемы	10 19 1 WR
10	Количество контактов на контактном круге избирателя
19	Макс. количество рабочих положений
1	Количество средних положений

Обозначение принципиальной схемы	10 19 1 WR
Вт	Исполнение предызбирателя W = реверсор G = грубая ступень
R	Тип привязки потенциала R = установленные потенциальные сопротивления S = переключатель потенциальных сопротивлений и потенциальные сопротивления на отдельной плите P = переключатель потенциальных сопротивлений с установленными потенциальными сопротивлениями

Табл. 2: Пример обозначения принципиальной схемы

## 1.2 Исполнения устройства РПН

В разделе «Обзор типов» [►Раздел 4.1, Страница 29] представлен обзор исполнений устройства РПН.

## 1.3 Принципиальные схемы

Далее представлены примеры принципиальных схем устройства РПН с обозначением присоединительных контактов избирателя по стандарту MR. Фактически выполнимые схемы соединений см. в разделе «Допустимые нагрузки напряжением».



Рис. 1: Принципиальные схемы без предызбирателя, VACUTAP® VM® I II III и VACUTAP® VMS® III, размерная серия избирателя С



Рис. 2: Принципиальные схемы при исполнении предызбирателя с реверсором, VACUTAP® VM® I II III и VACUTAP® VMS® III, раз- мерная серия избирателя С

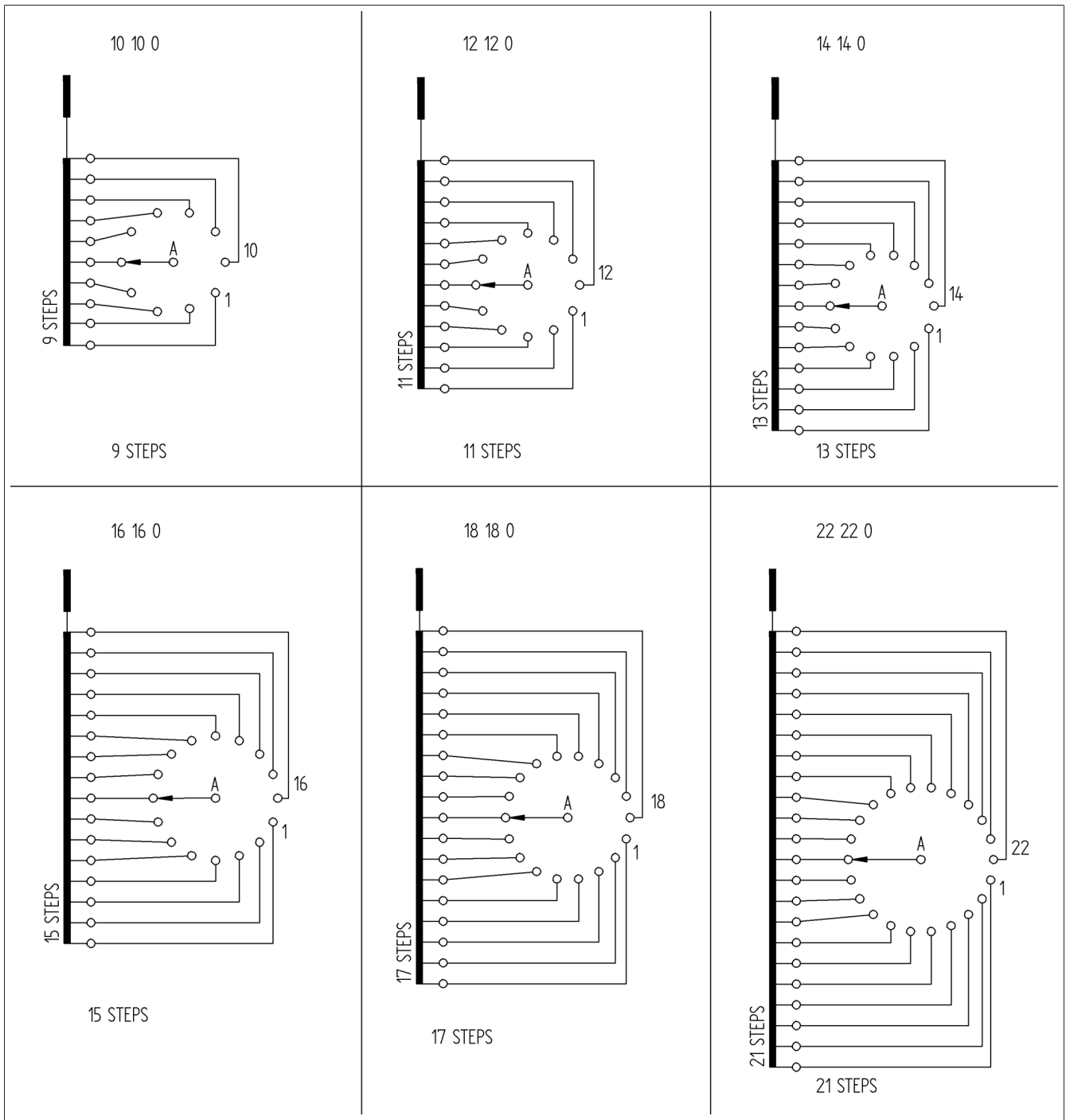

Рис. 3: Принципиальные схемы при переключении с грубой ступенью, VACUTAP® VM® I III и VACUTAP® VMS® III, размерная серия избирателя C

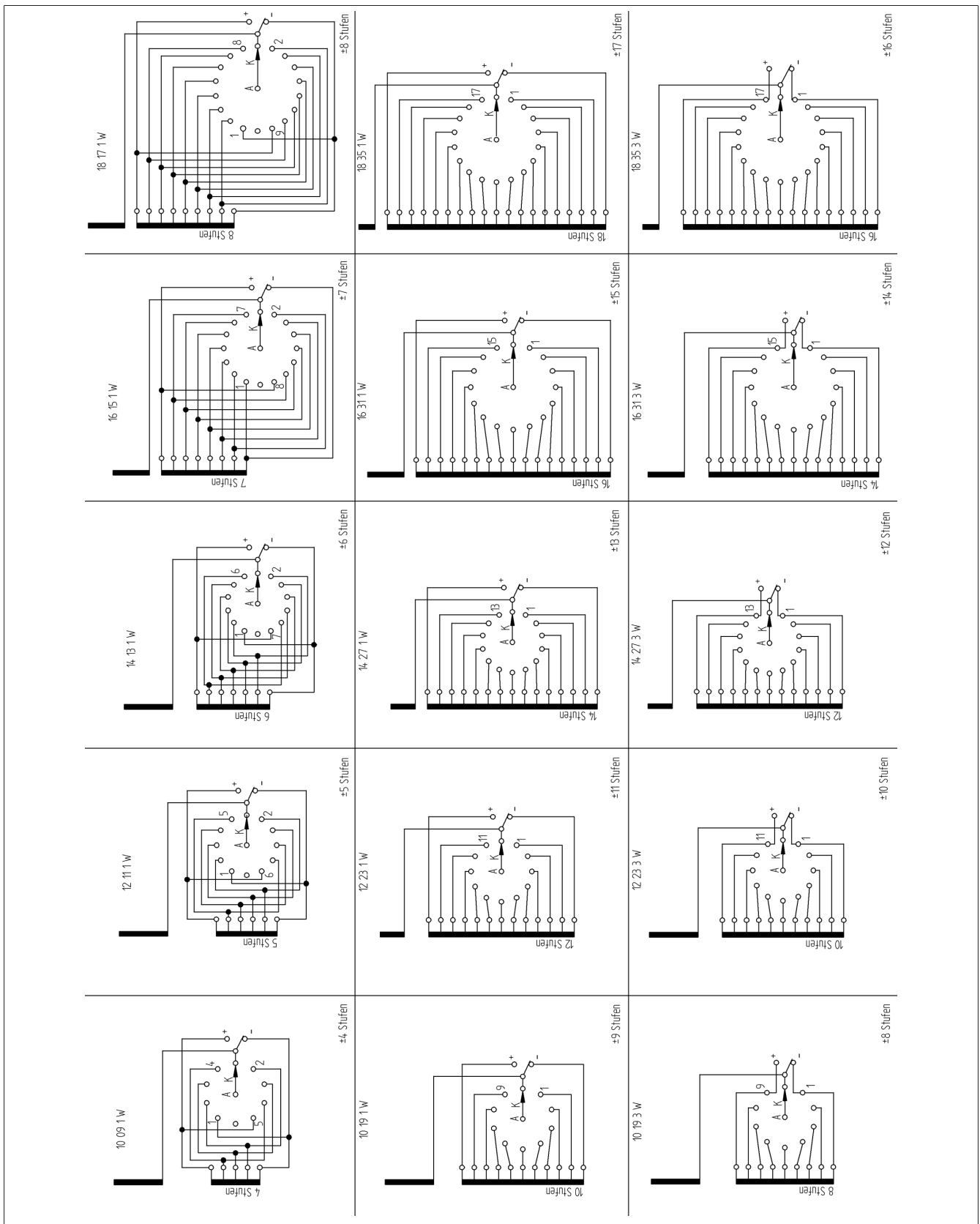

Рис. 4: Принципиальные схемы, VACUTAP® VM 300 и VACUTAP® VMS® III, размерная серия избирателя В

# 2 Технические характеристики

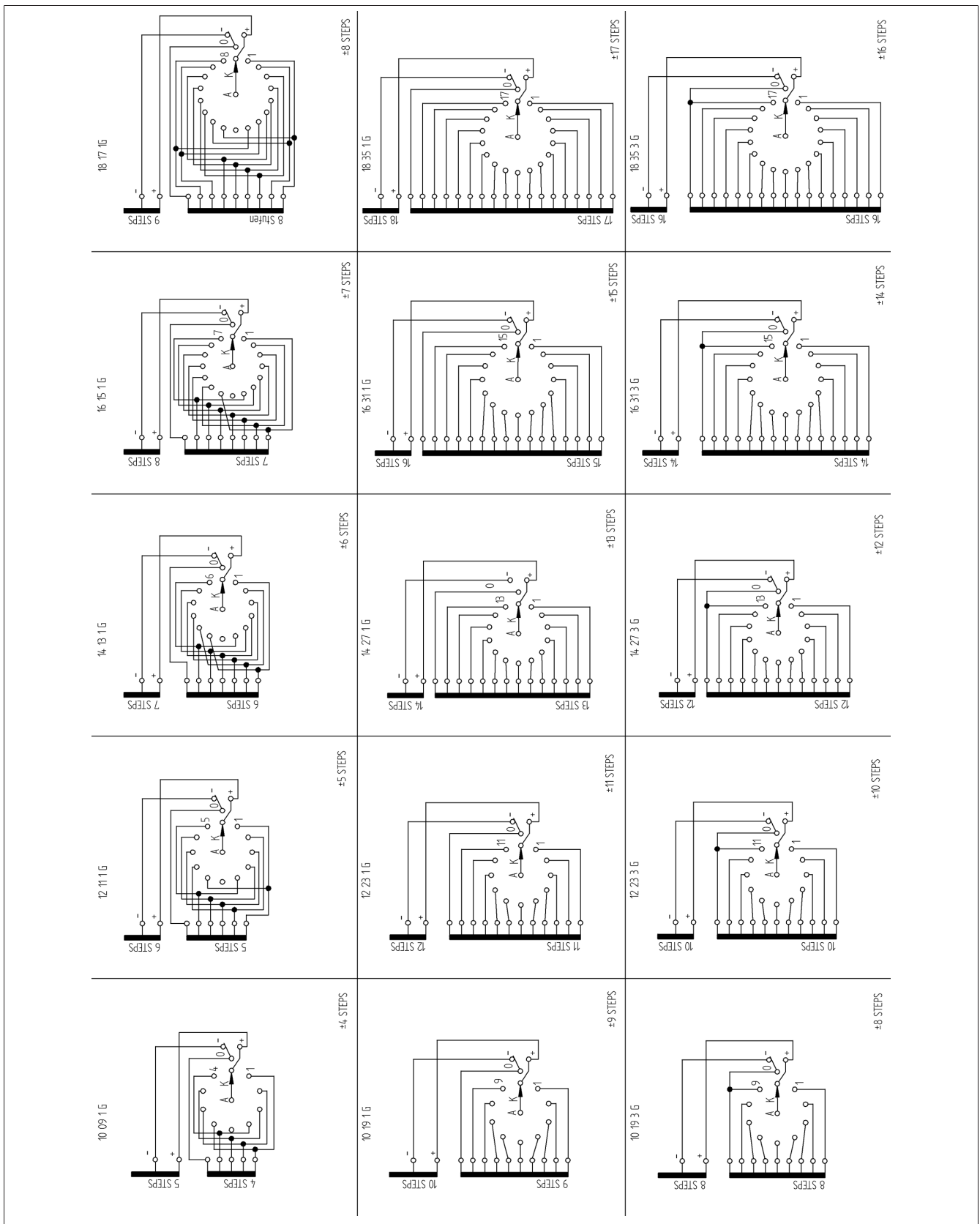
## 2.1 Характеристики устройства РПН

### Электрические характеристики VACUTAP® VM

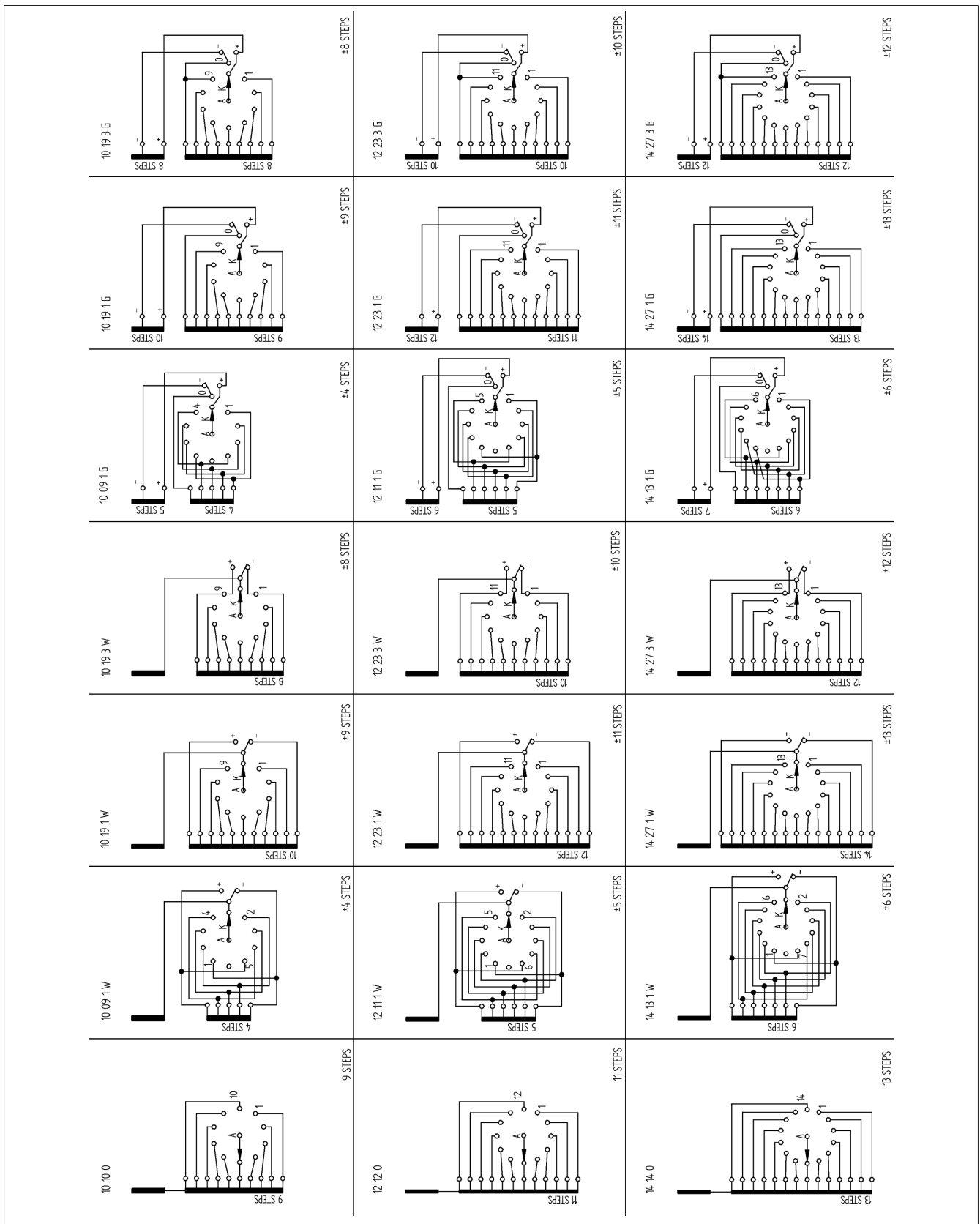
Устройство РПН	VM I 351	VM I 501	VM I 651	VM I 802	VM I 1002	VM I 1203	VM I 1503
Макс. расчетный рабочий ток $I_{rm}$ (A)	350	500	650	800	1 000	1 200	1 500
Расчетный кратковременный ток (кА)	4,2	5	6,5	8	10	12	15
Расчетная длительность к. з. (с)	3						
Расчетный ударный ток (кА)	10,5	12,5	16,25	20	25	30	37,5
Макс. расчетное напряжение ступени $U_{irm}$ (В) <sup>1</sup>	3 300						
Мощность ступени $P_{StN}$ (кВ·А)	1 155	1 625	1 625	2 600	2 600	3 500	3 500
Расчетная частота (Гц)	50...60						

Табл. 3: Электрические характеристики VACUTAP® VM I

Устройство РПН	VM II 352	VM II 502	VM II 652
Макс. расчетный рабочий ток $I_{rm}$ (A)	350	500	650
Расчетный кратковременный ток (кА)	4,2	5	6,5
Расчетная длительность к. з. (с)	3		
Расчетный ударный ток (кА)	10,5	12,5	16,25
Макс. расчетное напряжение ступени $U_{irm}$ (В) <sup>1</sup>	3 300		
Мощность ступени $P_{StN}$ (кВ·А)	1 155	1 625	1 625
Расчетная частота (Гц)	50...60		

Табл. 4: Электрические характеристики VACUTAP® VM II

Устройство РПН	VM III 350 Y	VM III 500 Y	VM III 650 Y
Макс. расчетный рабочий ток $I_{rm}$ (A)	350	500	650
Расчетный кратковременный ток (кА)	4,2	5	6,5
Расчетная длительность к. з. (с)	3		
Расчетный ударный ток (кА)	10,5	12,5	16,25
Макс. расчетное напряжение ступени $U_{irm}$ (В) <sup>1</sup>	3 300		
Мощность ступени ( $P_{StN}$ ) (кВ·А)	1 155	1 625	1 625
Расчетная частота (Гц)	50...60		

Табл. 5: Электрические характеристики VACUTAP® VM III

<sup>1</sup> Превышение максимального расчетного напряжения ступени на 10 %, обусловленное перевозбуждением трансформатора, допустимо, только если не превышена мощность ступени.

### Электрические характеристики VACUTAP® VM 300

Устройство РПН	VM I 301/VM II 302/VM III 300 Y
Макс. расчетный рабочий ток $I_{rm}$ (A)	300
Расчетный кратковременный ток (кА)	4
Расчетная длительность к. з. (с)	3
Расчетный ударный ток (кА)	10
Макс. расчетное напряжение ступени $U_{irm}$ (В) <sup>1</sup>	3 300
Мощность ступени $P_{stN}$ (кВ·А)	990
Расчетная частота (Гц)	50...60

Табл. 6: Электрические характеристики VACUTAP® VM 300

<sup>1</sup> Превышение максимального расчетного напряжения ступени на 10 %, обусловленное перевозбуждением трансформатора, допустимо, только если не превышена мощность ступени.

### Электрические характеристики VACUTAP® VMS®

Устройство РПН	VMS III 400 Y	VMS III 650 Y
Макс. расчетный рабочий ток $I_{rm}$ (A)	400	650
Расчетный кратковременный ток (кА)	4	6,5
Расчетная длительность к. з. (с)	3	
Расчетный ударный ток (кА)	10	16,25
Макс. расчетное напряжение ступени $U_{irm}$ (В) <sup>1</sup>	1 300	
Мощность ступени ( $P_{stN}$ ) (кВ·А)	520	845
Расчетная частота (Гц)	50...60	

Табл. 7: Электрические характеристики VACUTAP® VMS® III, размерная серия избирателя С

Устройство РПН	VMS III 400 Y
Макс. расчетный рабочий ток $I_{rm}$ (A)	400
Расчетный кратковременный ток (кА)	4
Расчетная длительность к. з. (с)	3
Расчетный ударный ток (кА)	10
Макс. расчетное напряжение ступени $U_{irm}$ (В) <sup>1</sup>	1 300
Мощность ступени ( $P_{stN}$ ) (кВ·А)	520
Расчетная частота (Гц)	50...60

Табл. 8: Электрические характеристики VACUTAP® VMS® III, размерная серия избирателя В



<sup>1</sup> Превышение максимального расчетного напряжения ступени на 10 %, обусловленное перевозбуждением трансформатора, допустимо, только если не превышена мощность ступени.

### Механические характеристики VACUTAP® VM

Количество рабочих положений	Без предызбирателя: макс. 18 С предызбирателем: макс. 35 С избирателем с несколькими грубыми ступенями: макс. 107
Количество оснащенных секторов	1...3
Размерные серии избирателя	B, C, D, DE (не для избирателя с несколькими грубыми ступенями)
Размеры	См. габаритные чертежи.
Вес	
Объем вытесняемого устройством РПН масла и масла в контакторе РПН	

Табл. 9: Механические характеристики VACUTAP® VM I III

### Механические характеристики VACUTAP® VM 300

Количество рабочих положений	Без предызбирателя: макс. 14 С предызбирателем: макс. 27
Количество оснащенных секторов	1...3
Размерные серии избирателя	B
Размеры	См. габаритные чертежи.
Вес	
Объем вытесняемого устройством РПН масла и масла в контакторе РПН	

Табл. 10: Механические характеристики VACUTAP® VM I 301/VM II 302/VM III 300 Y

### Механические характеристики VACUTAP® VMS®

Количество рабочих положений	Без предызбирателя: макс. 18 С предызбирателем: макс. 35
Количество оснащенных секторов	3
Размерные серии избирателя	C
Размеры	См. габаритные чертежи.
Вес	
Объем вытесняемого устройством РПН масла и масла в контакторе РПН	

Табл. 11: Механические характеристики VACUTAP® VMS® III, размерная серия избирателя C

Количество рабочих положений	Без предызбирателя: макс. 14 С предызбирателем: макс. 27
Количество оснащенных секторов	3
Размерные серии избирателя	B

Размеры	См. габаритные чертежи.
Вес	
Объем вытесняемого устройством РПН масла и масла в контакторе РПН	

Табл. 12: Механические характеристики VACUTAP<sup>®</sup> VMS<sup>®</sup> III, размерная серия избирателя В

## 2.2 Допустимые условия окружающей среды

Температура воздуха при эксплуатации	-25...50 °С
Температура изолирующей жидкости при работе	-25...105 °С (в аварийном режиме трансформатора до 115 °С)
Температура транспортировки и хранения	-40...50 °С
Температуры сушки	См. инструкцию по монтажу и вводу в эксплуатацию, раздел «Монтаж».
Прочность на сжатие	См. «Технические характеристики TD 61 — общая часть».
Изоляционная жидкость	<ul style="list-style-type: none"> <li>- Новые изоляционные масла из нефтепродуктов<sup>1</sup> согласно IEC 60296 и ASTM D3487 (эквивалентные стандарты по запросу).</li> <li>- Новые изоляционные масла из других первичных углеводородов согласно IEC 60296 или смеси этих масел с нефтепродуктами<sup>1</sup> согласно IEC 60296, ASTM D3487 или эквивалентным стандартам по запросу.</li> <li>- Альтернативные изоляционные жидкости, например натуральные и синтетические эфиры или силиконовые масла, используются по запросу.</li> </ul> <p><sup>1</sup> Газожидкостные масла (масла ГЖК) в данном контексте понимаются как нефтепродукты.</p>
Монтажная высота расширительного бака	См. «Технические характеристики TD 61 — общая часть».
Монтажная высота над уровнем моря	См. «Технические характеристики TD 61 — общая часть».

Табл. 13: Допустимые условия окружающей среды

## 2.3 Графики мощности ступеней

### 2.3.1 График мощности ступени для сетевого трансформатора VACUTAP® VM® и VM 300



Рис. 5: Мощность ступени (расчетное напряжение ступени)  $U_i$  при расчетном рабочем токе  $I_u$

### 2.3.2 График мощности ступени для VACUTAP® VM® и VM 300 при эксплуатации при дуговой электропечи

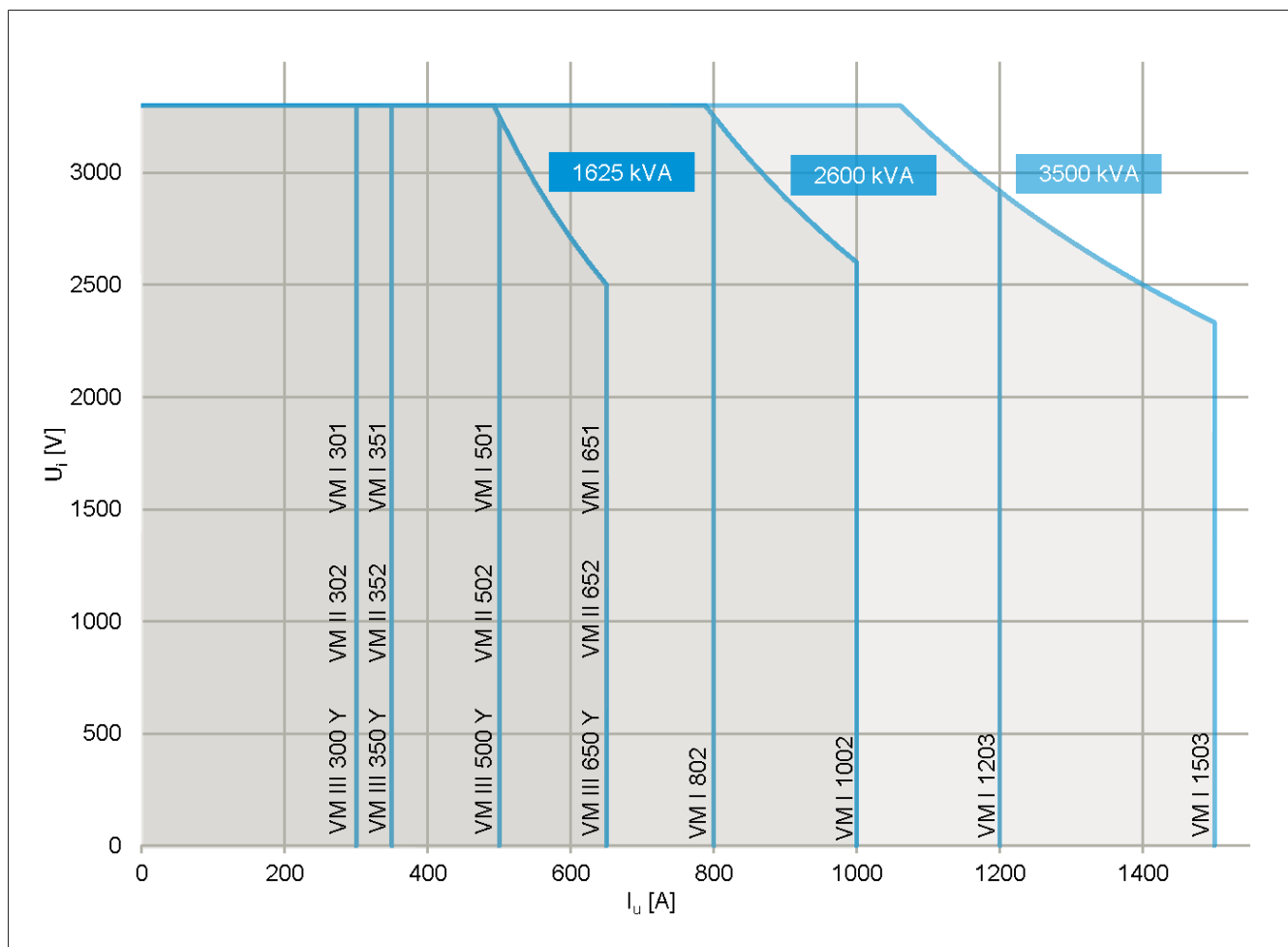

Рис. 6: Мощность ступени (расчетное напряжение ступени)  $U_{и}$ , при расчетном рабочем токе  $I_{р}$

### 2.3.3 График мощности ступени для сетевого трансформатора VACUTAP® VMS® III

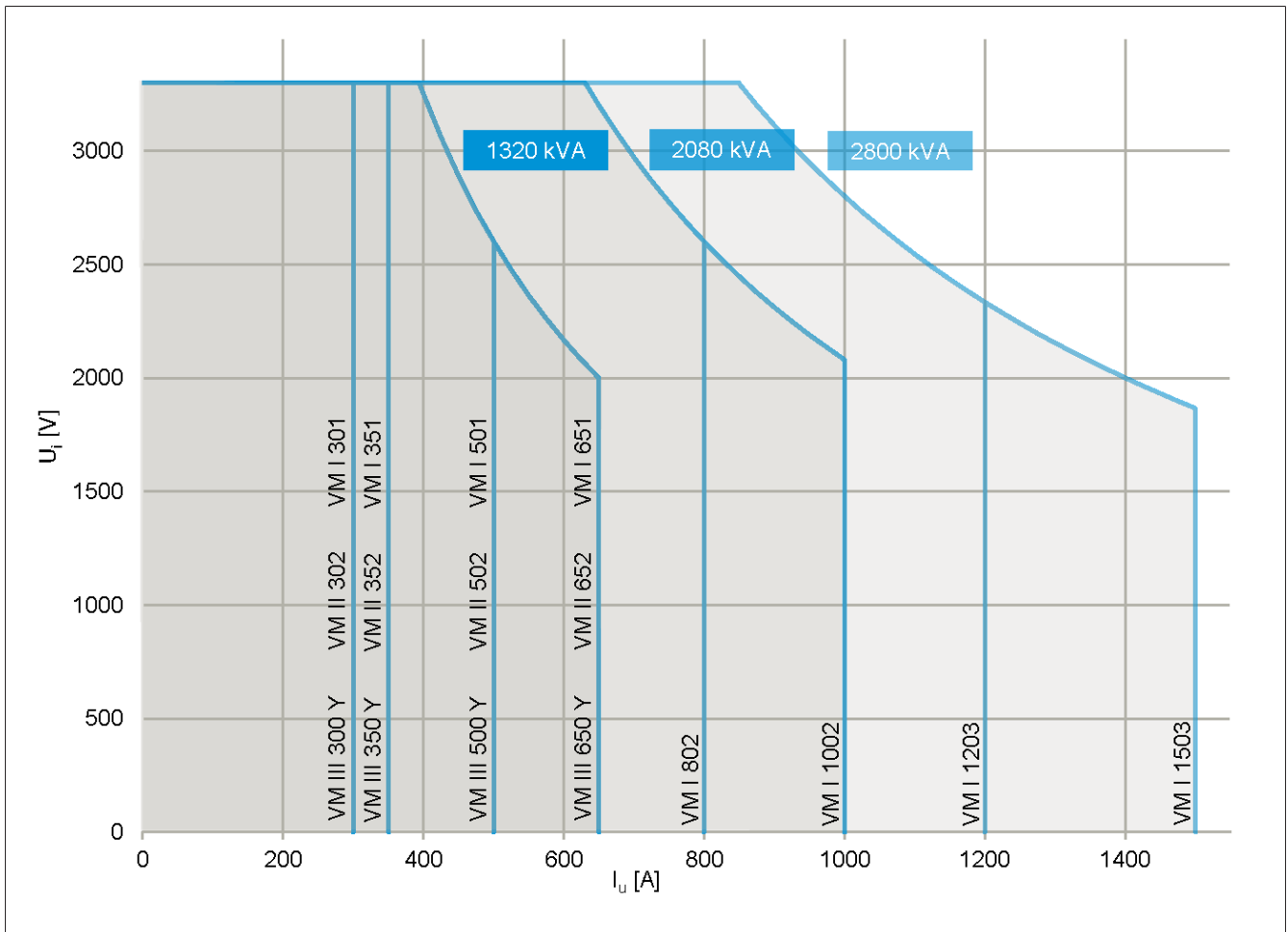

Рис. 7: Мощность ступени (расчетное напряжение ступени)  $U_{ir}$  при расчетном рабочем токе  $I_r$

## 2.4 Допустимые нагрузки напряжением

В этом разделе указаны допустимые нагрузки напряжением на устройство РПН.

При выборе устройства РПН следите за тем, чтобы наивысшие значения нагрузок не превышали расчетные выдерживаемые напряжения на изоляционных промежутках.

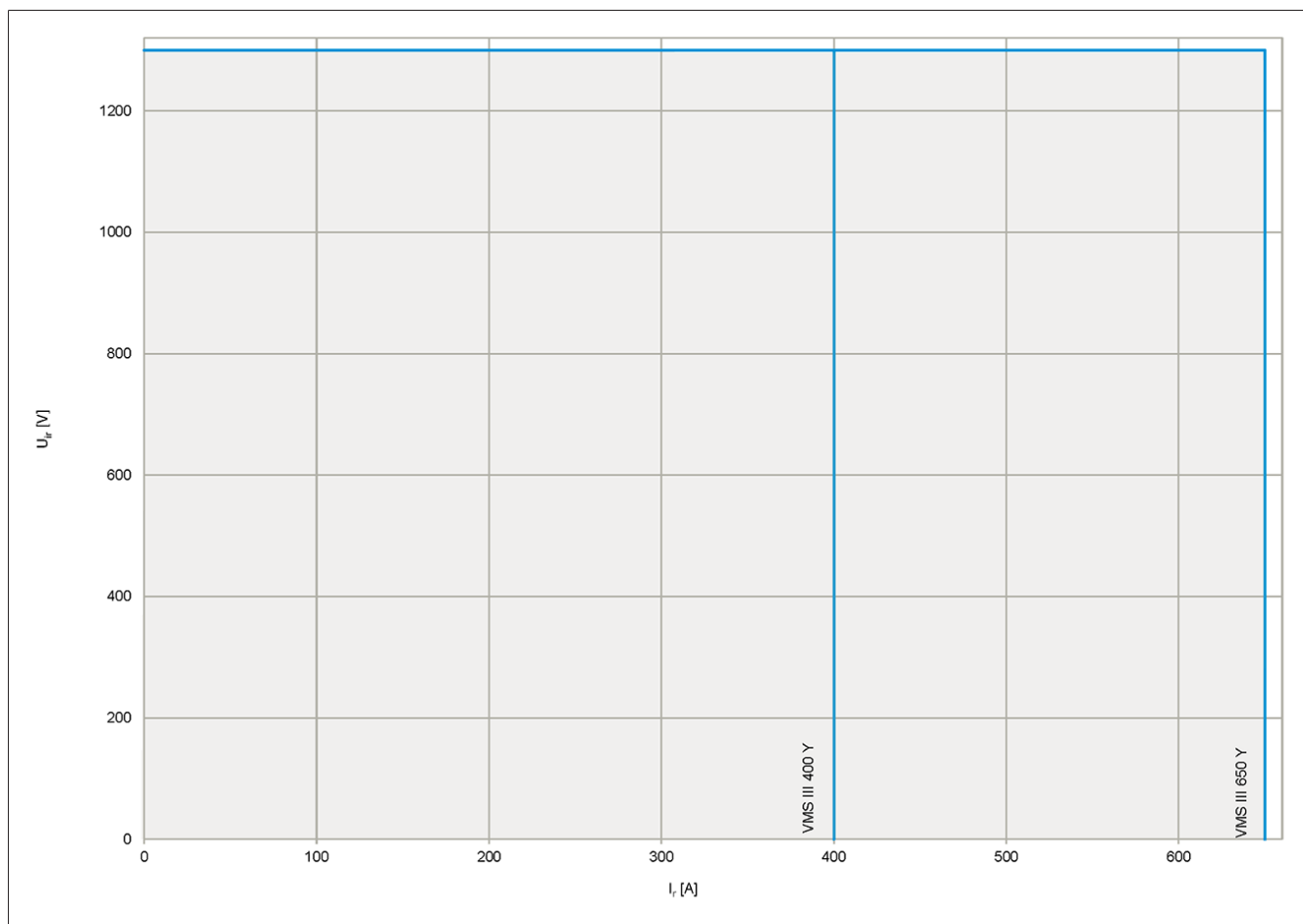
### 2.4.1 Изоляционные промежутки без избирателя с несколькими грубыми ступенями



Рис. 8: Изоляционные промежутки

a0	Между текущей и предварительно выбранной отпайкой на контакторе.
a1	Между контактами избирателя регулировочной обмотки одной ступени (подключенными или неподключенными).
a	Между началом и концом регулировочной обмотки, а в исполнениях с грубой ступенью также между началом и концом обмотки грубой ступени. Указание для переключения с грубой ступенью в положении предызбирателя –: прежде всего при нагрузке импульсным напряжением следует особо учитывать предельно допустимое испытательное напряжение а между концом обмотки грубой ступени, соединенной с контактом К избирателя, и контактом избирателя на конце регулировочной обмотки той же самой фазы.
b	Между контактами избирателя разных фаз и между контактами предызбирателя разных фаз, соединенных с началом или концом регулировочной обмотки или контактом избирателя.
f	Между отводящим контактом контактора и землей.
Дополнительно для переключения с грубой ступенью в положении предызбирателя +	
c1	От контакта – предызбирателя к отводу той же самой фазы.
c2	Между контактами – предызбирателя различных фаз.

### Краткие обозначения расчетного уровня изоляции

LI	Напряжение полного грозового импульса (кВ, 1,2/50 мкс)
LIC	Напряжение срезанного грозового импульса (кВ, 1,2/50/3 мкс)
SI	Напряжение коммутационного импульса (кВ, 250/2500 мкс)
AC	Приложенное напряжение (кВ, 50 Гц, 1 мин)

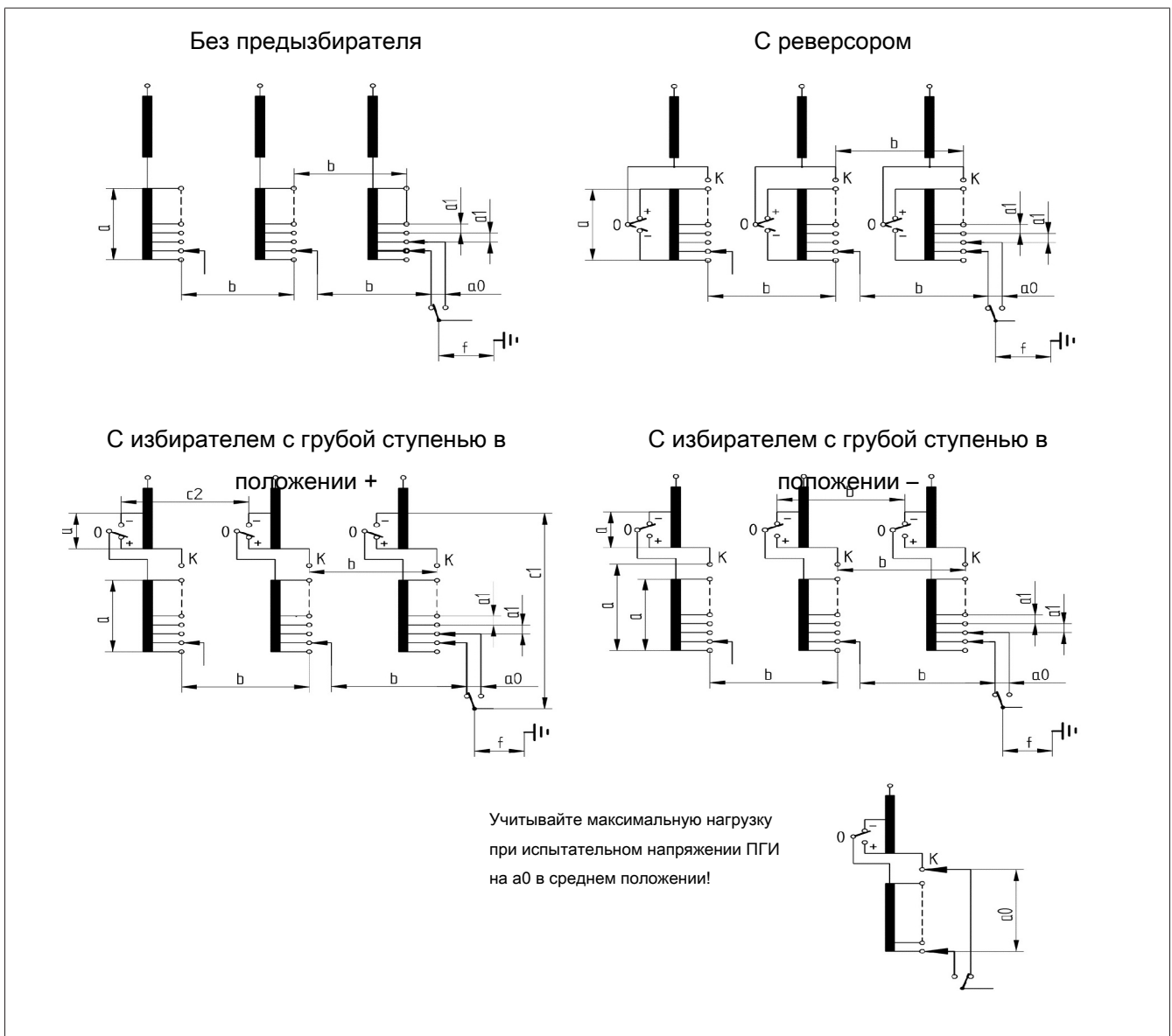
### Расчетный уровень изоляции контактора

Изоляционный промежуток f				
$U_m^1$	LI	LIC	SI	AC
72,5	350	385	-	140
123	550	605	460	230
170	750	825	620	325
245 <sup>2</sup>	1 050	1 155	850	460
300 <sup>2,3</sup>	1 050	1 155	850	460

Табл. 14: Расчетный уровень изоляции контактора

<sup>1</sup> Согласно IEC 60214-1 максимальное действующее значение напряжения между двумя фазами в трехфазной системе, на которое рассчитана изоляция устройства РПН.

<sup>2</sup> VACUTAP® VMS® только до  $U_m=170$  кВ.

<sup>3</sup> Только однофазные устройства РПН.

Расчетный уровень внутренней изоляции на избирателе для VACUTAP® VM® I II III (размерная серия избирателя В, С, D, DE) и VACUTAP® VMS® III (размерная серия избирателя С, без избирателя с несколькими грубыми ступенями)

Максимально допустимое рабочее напряжение на отдельных изоляционных промежутках избирателя соответствует половине приведенных ниже значений приложенного напряжения (АС).

Изоляционный промежуток		Размерная серия избирателя			
		В	С	D	DE
a0	LI	150 <sup>2</sup>			150 <sup>2</sup>
	LIC	165 <sup>2</sup>			165 <sup>2</sup>
	SI	100 <sup>2</sup>			100 <sup>2</sup>
	AC	20			20
a1	LI	150			150
	LIC	165			165
	SI	100			100
	AC	30			30
a	LI	265	350	490	550
	LIC	295	385	540	605
	SI	175	230	320	360
	AC	50	82	105	120
b <sup>1</sup>	LI	265	350	490	550
	LIC	295	385	540	605
	SI	175	230	320	360
	AC	50	82	146	160
c1	LI	485	545	590	660
	LIC	535	600	650	725
	SI	315	355	385	430
	AC	143	178	208	230
c2 <sup>1</sup>	LI	495	550	590	660
	LIC	545	605	650	725
	SI	325	360	385	430
	AC	150	182	225	250

Табл. 15: Расчетный уровень внутренней изоляции избирателя

<sup>1</sup> Не требуется для однофазных устройств РПН.

<sup>2</sup> Напряжение срабатывания варистора при полном грозовом импульсе 1,2/50 мкс: от 45 кВ ( $U_{100\%}(t)_{\text{норм}} \neq U_{75\%}(t)_{\text{норм}}$ ), остаточное напряжение при импульсном токе 3 кА: 56 кВ.



Расчетный уровень внутренней изоляции на избирателе для VACUTAP® VM 300 и VACUTAP® VMS® III (размерная серия избирателя В, без избирателя с несколькими грубыми ступенями)  
 Максимально допустимое рабочее напряжение на отдельных изоляционных промежутках избирателя соответствует половине приведенных ниже значений приложенного напряжения (АС).

Изоляционный промежуток		Размерная серия избирателя В
a0	LI	150 <sup>1</sup>
	LIC	165 <sup>1</sup>
	SI	100 <sup>1</sup>
	AC	20
a	LI	300
	LIC	330
	SI	195
	AC	70
b	LI	300
	LIC	330
	SI	195
	AC	70
c1	LI	400
	LIC	440
	SI	260
	AC	120
C2	LI	400
	LIC	440
	SI	260
	AC	120

Табл. 16: Расчетный уровень внутренней изоляции избирателя

<sup>1</sup>Напряжение срабатывания варистора при полном грозовом импульсе 1,2/50 мкс: от 45 кВ ( $U_{100\%}(t)_{норм} \neq U_{75\%}(t)_{норм}$ ), остаточное напряжение при импульсном токе 3 кА: 56 кВ.

## 2.4.2 Изоляционные промежутки с избирателем с несколькими грубыми ступенями



Рис. 9: Изоляционные промежутки для VACUTAP® VM® I II III (размерная серия избирателя B, C, D, с избирателем с несколькими грубыми ступенями)

a0	Между текущей и предварительно выбранной отпайкой на контакторе.
a1	Между контактами избирателя регулировочной обмотки одной ступени (подключенными или неподключенными).
a	Между началом и концом регулировочной обмотки и между подключенным контактом К и любыми точками регулировочной обмотки той же самой фазы.
b	Между контактами избирателя разных фаз и между подключенным контактом К одной фазы и любыми точками регулировочной обмотки другой фазы.
c1	Между любыми отпайками грубой ступени одной фазы и отводящим контактом контактора той же самой фазы.
c2	Между одноименными неподключенными отпайками грубой ступени разных фаз.
d1	Между подключенным и соседним с ним контактом грубой ступени в одной фазе.
d2	Между неподключенными соседними контактами грубой ступени в одной фазе.
d3	Между началом и концом всех грубых ступеней одной фазы.
f	Между отводящим контактом контактора и землей.

Изоляционный промежуток f см. в пункте «Расчетный уровень изоляции контактора».

Расчетный уровень внутренней изоляции на избирателе с избирателем с несколькими грубыми ступенями, VACUTAP® VM® I II III (размерная серия избирателя В, С, D)

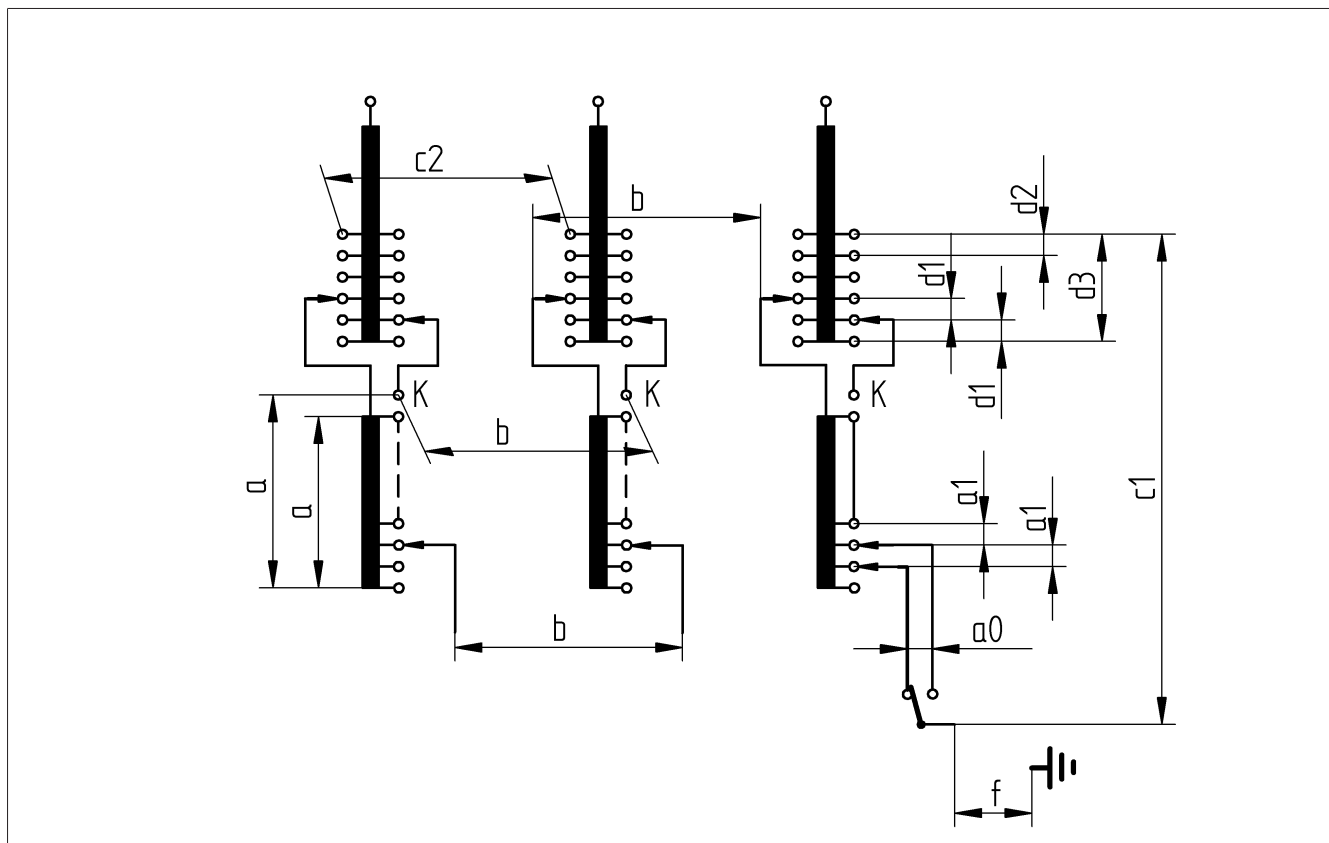
Максимально допустимое рабочее напряжение на отдельных изоляционных промежутках избирателя соответствует половине приведенных ниже значений приложенного напряжения (АС).

Изоляционный промежуток		Размерная серия избирателя		
		В	С	Д
a0	LI	150 <sup>2</sup>		
	LIC	165 <sup>2</sup>		
	SI	100 <sup>2</sup>		
	АС	20		
a1	LI	150		
	LIC, SI	Значения по запросу.		
	АС	30		
a	LI	265	350	450
	LIC, SI	Значения по запросу.		
	АС	50	82	105
b <sup>1</sup>	LI	265	350	450
	LIC, SI	Значения по запросу.		
	АС	50	82	146
c1	LI	455	525	590
	LIC, SI	Значения по запросу.		
	АС	127	165	210
c2 <sup>1</sup>	LI	455	525	590
	LIC, SI	Значения по запросу.		
	АС	127	165	215
d1	LI	265	350	450
	LIC, SI	Значения по запросу.		
	АС	50	82	105
d2	LI	350	450	450
	LIC, SI	Значения по запросу.		
	АС	82	105	105
d3	LI	350	450	490
	LIC, SI	Значения по запросу.		
	АС	82	105	120

Табл. 17: Расчетный уровень внутренней изоляции на избирателе с избирателем с несколькими грубыми ступенями

<sup>1</sup> Не требуется для однофазных устройств РПН.

<sup>2</sup> Напряжение срабатывания варистора при полном грозовом импульсе 1,2/50 мкс: от 45 кВ ( $U_{100\%}(t)_{\text{норм}} \neq U_{75\%}(t)_{\text{норм}}$ ), остаточное напряжение при импульсном токе 3 кА: 70 кВ.

## 2.4.3 Возможные схемы

### Возможные схемы с соответствующими размерными сериями избирателя для VACUTAP® VM® I II III

Указанные ниже схемы возможны при исполнении предызбирателя с реверсом и тремя средними положениями (3W), а также предызбирателя с грубой ступенью и тремя средними положениями (3G).

Без предызбирателя		С реверсором		С избирателем с грубой ступенью	
Схема соединения	Размерная серия избирателя	Схема соединения	Размерная серия избирателя	Схема соединения	Размерная серия избирателя
10050	B/C/D/DE	10071W	B/C/D/DE	10071G	B/C/D/DE
10060	B/C/D/DE	10081W	B/C/D/DE	10081G	B/C/D/DE
10070	B/C/D/DE	10091W	B/C/D/DE	10091G	B/C/D/DE
10080	B/C/D/DE	12101W	B/C/D/DE	12101G	B/C/D/DE
10090	B/C/D/DE	12111W	B/C	12111G	B/C
10100	B/C/D/DE	14111W	D/DE	14111G	D/DE
12110	B/C/D/DE	14121W	B/C	14121G	B/C
12120	B/C/D/DE	14131W	B/C	14131G	B/C
14130	B/C/D/DE	16121W	D/DE	16121G	D/DE
14140	B/C/D/DE	16131W	D/DE	16131G	D/DE
16150	B/C/D/DE	16141W	B/C/D/DE	16141G	B/C/D/DE
16160	B/C/D/DE	16151W	B/C	16151G	B/C
18170	B/C/D/DE	18151W	D/DE	18151G	D/DE
18180	B/C/D/DE	18161W	B/C	18161G	B/C
22190	B/C/D/DE	18171W	B/C	18171G	B/C
22200	B/C/D/DE	10191W	B/C/D/DE	10191G	B/C/D/DE
22210	B/C	12231W	B/C/D/DE	12231G	B/C/D/DE
22220	B/C	14271W	B/C/D/DE	14271G	B/C/D/DE
		16311W	B/C/D/DE	16311G	B/C/D/DE
		18351W	B/C/D/DE	18351G	B/C/D/DE

Табл. 18: Возможные схемы для VACUTAP® VM® I II III

### Возможные схемы для VACUTAP® VMS® III, размерная серия избирателя С

Указанные ниже схемы возможны при исполнении предызбирателя с реверсом и тремя средними положениями (3W), а также предызбирателя с грубой ступенью и тремя средними положениями (3G).

Переключение без предызбирателя	Переключение с реверсором	Переключение с избирателем с грубой ступенью
10050	10071W	10071G
10060	10081W	10081G
10070	10091W	10091G
10080	12101W	12101G

Переключение без предызбирателя	Переключение с реверсором	Переключение с избирателем с грубой ступенью
10090	12111W	12111G
10100	14121W	14121G
12110	14131W	14131G
12120	16141W	16141G
14130	16151W	16151G
14140	18161W	18161G
16150	18171W	18171G
16160	10191W	10191G
18170	12231W	12231G
18180	14271W	14271G
	16311W	16311G
	18351W	18351G

Табл. 19: Возможные схемы для VACUTAP® VMS® III, размерная серия избирателя С

### Возможные схемы для VACUTAP® VM 300 и VACUTAP® VMS® III, размерная серия избирателя В

Схемы, отмеченные цифрой <sup>1</sup>, возможны при исполнении предызбирателя с реверсом и тремя средними положениями (3W), а также предызбирателя с грубой ступенью и тремя средними положениями (3G).

Переключение без предызбирателя	Переключение с реверсором	Переключение с избирателем с грубой ступенью
10100	10091W	10091G
12120	12111W	12111G
14140	14131W	14131G
	10191W <sup>1</sup>	10191G <sup>1</sup>
	12231W <sup>1</sup>	12231G <sup>1</sup>
	14271W <sup>1</sup>	14271G <sup>1</sup>

Табл. 20: Возможные схемы для VACUTAP® VMS® III, размерная серия избирателя В

## 3 Специальные исполнения

### 3.1 Перемычки для параллельного подключения уровней избирателя

Деление тока на присоединительных контактах осуществляется с помощью двух параллельных уровней избирателя только на устройствах РПН VACUTAP® VM I 802/1002 и трех уровней избирателя только на устройствах VACUTAP® VM I 1203/1503.

Перемычки на присоединительных контактах избирателя необходимы, если регулировочная обмотка намотана в два или более проводника и каждый из этих проводников обмотки подводится в качестве отпайки к присоединительным контактам избирателя.

Эта мера препятствует:

- переходу уравнивающих токов в токопроводы избирателя и контактора;
- возникновению электрической дуги на подвижных перемычках между контактами избирателя;
- перенапряжению между соседними параллельно соединенными присоединительными контактами избирателя.

### 3.2 Комбинация устройств РПН для схемы соединения обмотки «треугольник»

Однофазные устройства РПН можно комбинировать с двухфазными устройствами РПН для регулирования напряжения обмоток трансформатора в схеме соединения обмотки «треугольник». Эта двухколонковая комбинация устройств РПН обозначается как VM III К (К — комбинация).

Возможные комбинации устройств РПН представлены ниже.

- VM I 301 с VM II 302
- VM I 351 с VM II 352
- VM I 501 с VM II 502
- VM I 651 с VM II 652

Соединение регулировочных обмоток должно соответствовать представленной ниже схеме.



Рис. 10: Комбинация устройств РПН VM III К для схемы соединения обмотки «треугольник» VM I 351/VM II 352 (a = VM I 351, b = VM II 352)

### 3.3 Устройство РПН VACUTAP® VM III 650 Y...VM I 1503 с избирателем с несколькими грубыми ступенями (макс. пять грубых ступеней)

Чтобы наиболее точно регулировать напряжение, требуется большое количество рабочих положений, которое может быть достигнуто при использовании избирателя с несколькими грубыми ступенями.

Например, использование избирателя с пятью грубыми ступенями и регулировочной обмотки с 18 отпайками позволяет достигнуть 107 рабочих положений.

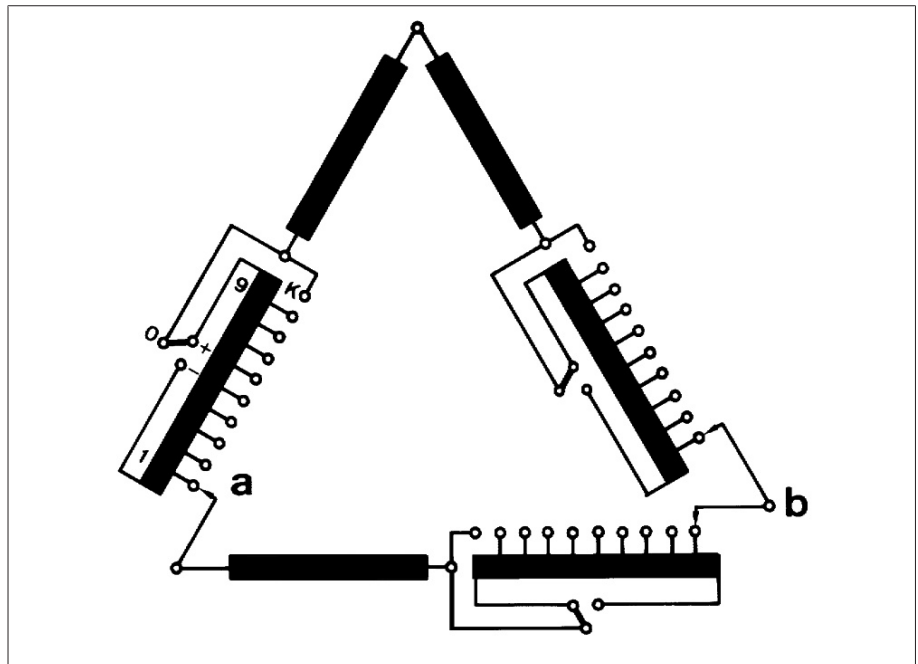
Грубые ступени расположены по обеим сторонам избирателя.

Возможна поставка устройств РПН для  $U_m = 72,5-300$  кВ и 2-5 грубых ступеней (конструктивный ряд избирателя В, С и D).

### 3.4 Двухфазное устройство РПН VACUTAP® VM II 302/352/502/652

Устройство РПН VM II 302/352/502/652 может поставляться в качестве двухфазного устройства РПН для однофазного выпрямителя со средней точкой, технические характеристики которого соответствуют характеристикам устройства РПН VM III 300 Y, VM III 350 Y, VM III 500 Y или VM III 650 Y.

### 3.5 Устройство РПН для соединения по схеме «звезда» с разомкнутой нейтралью звезды

Если устройство РПН имеет разомкнутую нейтраль звезды, то к ней можно подсоединять **только трансформаторы тока**, иначе на нейтрали звезды возникает недопустимое перенапряжение.



Запрещается подсоединять дроссельные катушки.

Подключение трех отводов масляного бака контактора (= разомкнутая нейтраль звезды)	VACUTAP VM III 300/350/500/650 Y	
Присоединение трансформатора тока и создание нейтрали звезды снаружи устройства РПН	А) Допустимые испытательные напряжения между отводящими контактами масляного бака контактора	
	– Расчетное выдерживаемое напряжение грозового импульса	< 140 кВ (1,2/50 мкс) <sup>1)</sup>
	– Расчетное напряжение ПЧ	1 кВ (50 Гц, 1 мин)
	В) Максимально допустимое рабочее напряжение между отводящими контактами масляного бака контактора	
<sup>1)</sup> Напряжение срабатывания варистора при полном грозовом импульсе 1,2/50 мкс: > 1,4 кВ; остаточное напряжение при импульсном токе 1000 А (8/20 мкс): < 3 кВ; максимально допустимая энергетическая нагрузка варистора < 100 Дж		

Табл. 21: Допустимые испытательные и рабочие напряжения для VACUTAP® VM III 300/350/500/650 Y



# 4 Чертежи

## 4.1 Обзор типов

© MASCHINENFABRIK REINHAUSEN GMBH 2018  
 THE REPRODUCTION, DISTRIBUTION AND UTILIZATION OF THIS DOCUMENT AS WELL AS THE COMMUNICATION OF ITS CONTENTS TO OTHERS WITHOUT EXPRESS AUTHORIZATION IS PROHIBITED. OFFENDERS WILL BE HELD LIABLE FOR THE PAYMENT OF DAMAGES. ALL RIGHTS RESERVED IN THE EVENT OF THE GRANT OF A PATENT, UTILITY MODEL OR DESIGN.

DATE	NAME	DOCUMENT NO.
DFTR. 13.07.2018	BUTERUS	SED 1663609 000 04
CHKD. 16.07.2018	WILHELM	SCALE
STAND. 16.07.2018	PRODASTSCHUK	CHANGE NO. 1086956

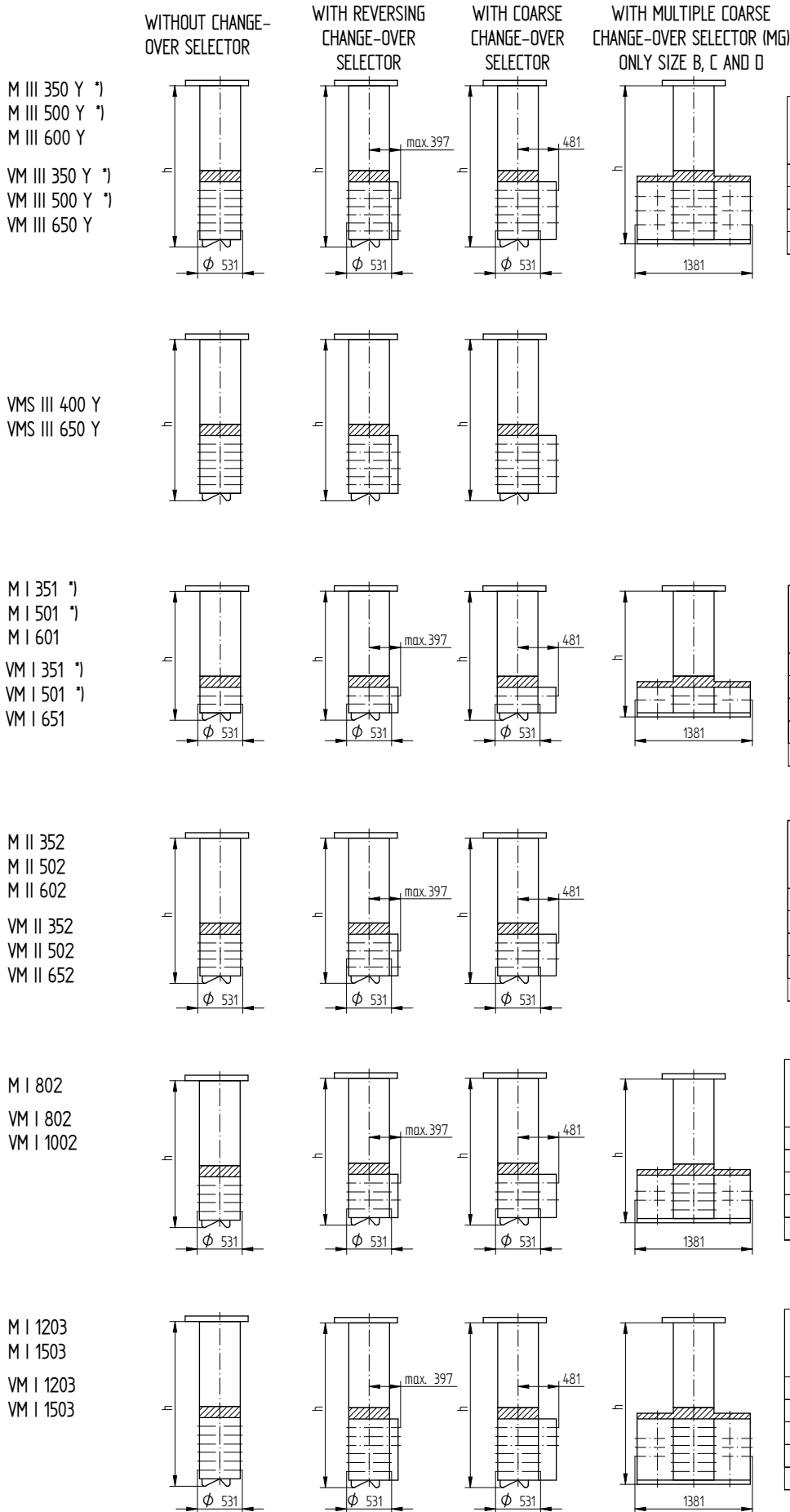

M III 350 Y \*)  
 M III 500 Y \*)  
 M III 600 Y  
 VM III 350 Y \*)  
 VM III 500 Y \*)  
 VM III 650 Y

VMS III 400 Y  
 VMS III 650 Y

M I 351 \*)  
 M I 501 \*)  
 M I 601  
 VM I 351 \*)  
 VM I 501 \*)  
 VM I 651

M II 352  
 M II 502  
 M II 602  
 VM II 352  
 VM II 502  
 VM II 652

M I 802  
 VM I 802  
 VM I 1002

M I 1203  
 M I 1503  
 VM I 1203  
 VM I 1503

\*) NOT AVAILABLE AS MULTIPLE COARSE CHANGE-OVER SELECTOR (MG)

INSTALLATION LENGTH h IN MM

U <sub>m</sub> [kV]	SELECTOR SIZE					
	B		C		D/DE	D
	0/W/G	MG	0/W/G	MG	0/W/G	MG
72,5	1894	1856	2069	2031	2524	2486
123	2024	1986	2199	2161	2654	2616
170	2154	2116	2329	2291	2784	2746
245	2254	2216	2429	2391	2884	2846

U <sub>m</sub> [kV]	SELECTOR SIZE	
	C	
	0/W/G	
72,5	2069	
123	2199	
170	2329	

U <sub>m</sub> [kV]	SELECTOR SIZE					
	B		C		D/DE	D
	0/W/G	MG	0/W/G	MG	0/W/G	MG
72,5	1514	1476	1589	1551	1784	1746
123	1644	1606	1719	1681	1914	1876
170	1774	1736	1849	1811	2044	2006
245	1874	1836	1949	1911	2144	2106
300	2026	1988	2101	2063	2296	2258

U <sub>m</sub> [kV]	SELECTOR SIZE			
	B	C	D/DE	
	0/W/G	0/W/G	0/W/G	
72,5	1704	1829	2154	
123	1834	1959	2284	
170	1964	2089	2414	
245	2064	2189	2514	
300	2216	2341	2666	

U <sub>m</sub> [kV]	SELECTOR SIZE					
	B		C		D/DE	D
	0/W/G	MG	0/W/G	MG	0/W/G	MG
72,5	1724	1686	1799	1761	1994	1956
123	1854	1816	1929	1891	2124	2086
170	1984	1946	2059	2021	2254	2216
245	2084	2046	2159	2121	2354	2316
300	2236	2198	2311	2273	2506	2468

U <sub>m</sub> [kV]	SELECTOR SIZE					
	B		C		D/DE	D
	0/W/G	MG	0/W/G	MG	0/W/G	MG
72,5	1934	1896	2009	1971	2204	2166
123	2064	2026	2139	2101	2334	2296
170	2194	2156	2269	2231	2464	2426
245	2294	2256	2369	2331	2564	2526
300	2446	2408	2521	2483	2716	2678

DIMENSION IN mm EXCEPT AS NOTED



ON-LOAD TAP-CHANGER OILTAP® M / VACUTAP® VM®, VMS®-C  
M-SELECTOR SIZE B/C/D/DE  
SURVEY OF MODELS

SERIAL NUMBER

MATERIAL NUMBER 8997404E SHEET 1/1

© MASCHINENFABRIK REINHAUSEN GMBH 2018  
 THE REPRODUCTION, DISTRIBUTION AND UTILIZATION OF THIS DOCUMENT AS WELL AS THE COMMUNICATION OF ITS CONTENTS TO OTHERS WITHOUT EXPRESS AUTHORIZATION IS PROHIBITED. OFFENDERS WILL BE HELD LIABLE FOR THE PAYMENT OF DAMAGES. ALL RIGHTS RESERVED IN THE EVENT OF THE GRANT OF A PATENT, UTILITY MODEL OR DESIGN.

WITHOUT  
CHANGE-OVER SELECTOR

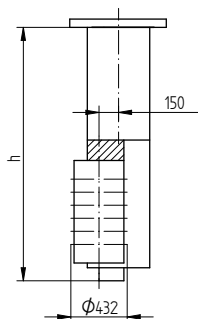

WITH  
CHANGE-OVER SELECTOR

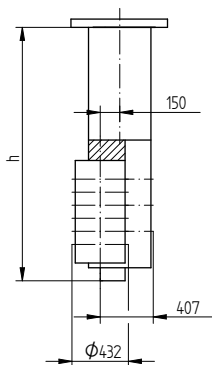

INSTALLATION LENGTH h IN MM

VMS III 400 Y

U <sub>m</sub> [kV]	SELECTOR SIZE B
72,5	1942
123	2072
170	2202

DATE	NAME	DOCUMENT NO.
11.07.2018	BUTERUS	SED 6185260 001 00
CHKD. 16.07.2018	WILHELM	CHANGE NO.
STAND. 16.07.2018	PRODASTSCHUK	1086956
		SCALE
		-

DIMENSION  
IN mm  
EXCEPT AS  
NOTED



ON-LOAD TAP-CHANGER VACUTAP® VMS®  
 SELECTOR SIZE B  
 SURVEY OF MODELS

SERIAL NUMBER

MATERIAL NUMBER	SHEET
101170260E	1/1

© MASCHINENFABRIK REINHAUSEN GMBH 2016  
 THE REPRODUCTION, DISTRIBUTION AND UTILIZATION OF THIS DOCUMENT AS WELL AS THE COMMUNICATION OF ITS CONTENTS TO OTHERS WITHOUT EXPRESS AUTHORIZATION IS PROHIBITED. OFFENDERS WILL BE HELD LIABLE FOR THE PAYMENT OF DAMAGES. ALL RIGHTS RESERVED IN THE EVENT OF THE GRANT OF A PATENT, UTILITY MODEL OR DESIGN.

DATE	NAME	DOCUMENT NO.
22.01.2016	RAEDLINGER	SED 24:16819 001 01
25.02.2016	TKBIRKMANN	CHANGE NO.
25.02.2016	PRODASTSCHUK	1072100
SCALE		-

DIMENSION  
IN mm  
EXCEPT AS  
NOTED



ON-LOAD TAP-CHANGER VACUTAP® VM 300  
SELECTOR SIZE B  
SURVEY OF MODELS

SERIAL NUMBER

MATERIAL NUMBER  
7658351E

SHEET  
1/1

without  
change-over selector

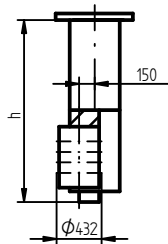
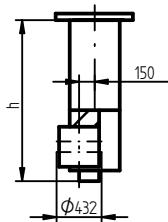
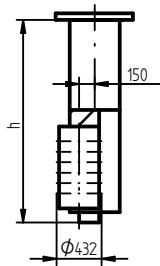

with  
change-over selector

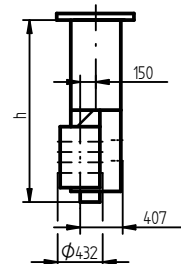
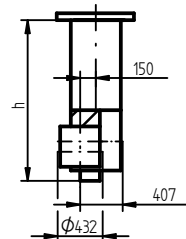
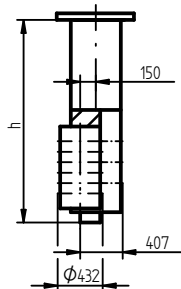

Installation length  $h$  in mm

VM III 300 Y

$U_m$ [kV]	Selector size B
72,5	1942
123	2072
170	2202
245	2302

VM I 301

$U_m$ [kV]	Selector size B
72,5	1542
123	1672
170	1802
245	1902

VM II 302

$U_m$ [kV]	Selector size B
72,5	1742
123	1872
170	2002
245	2102

## 4.2 габаритные чертежи;

© MASCHINENFABRIK REINHAUSEN GMBH 2015  
 THE REPRODUCTION, DISTRIBUTION AND UTILIZATION OF THIS DOCUMENT AS WELL AS THE COMMUNICATION OF ITS CONTENTS TO OTHERS WITHOUT EXPRESS AUTHORIZATION IS PROHIBITED. OFFENDERS WILL BE HELD LIABLE FOR THE PAYMENT OF DAMAGES. ALL RIGHTS RESERVED IN THE EVENT OF THE GRANT OF A PATENT, UTILITY MODEL OR DESIGN.

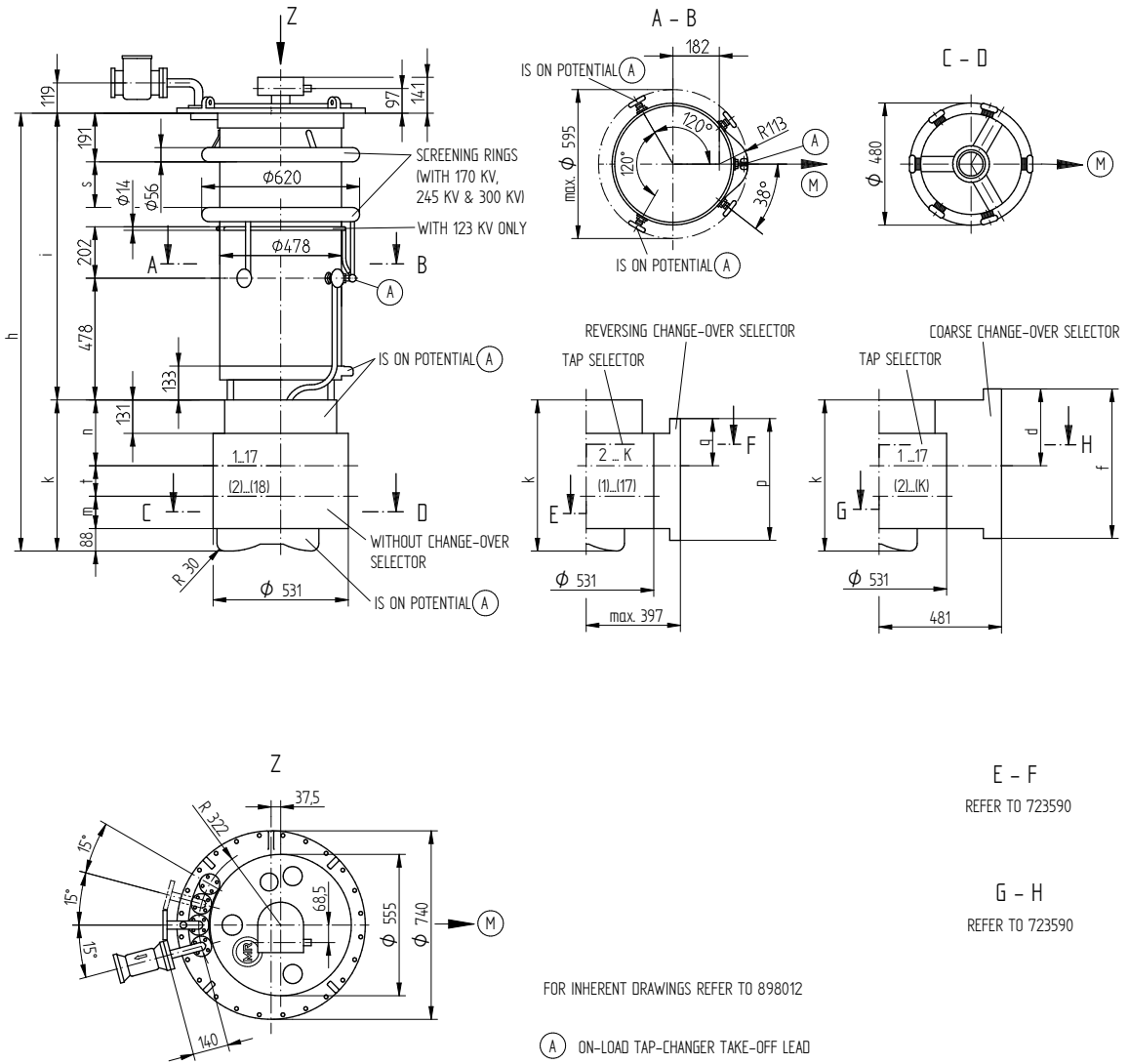

FOR INHERENT DRAWINGS REFER TO 898012

(A) ON-LOAD TAP-CHANGER TAKE-OFF LEAD

(M) DRIVE SIDE OF SELECTOR

FOR BINDING DESIGNATIONS OF TERMINALS AND PHASES REFER TO THE CONNECTION DIAGRAM OF THE ON-LOAD TAP-CHANGER.

SELECTOR SIZE	B					C					D / DE					
	U <sub>M</sub> [KV]	72,5	123	170	245	300	72,5	123	170	245	300	72,5	123	170	245	300
DIMENSIONS [MM]	h	1514	1644	1774	1874	2026	1589	1719	1849	1949	2101	1784	1914	2044	2144	2296
	i	996	1126	1256	1356	1508	996	1126	1256	1356	1508	996	1126	1256	1356	1508
	s	-	-	267	367	520	-	-	267	367	520	-	-	267	367	520
	k	518					593					788				
	n	233					258					323				
	m	102					127					192				
	t	95					120					185				
	q	160					185					250				
	p	403					478					673				
	d	276.5					3015					366.5				
f	512					587					782					
OIL VOLUME [DM <sup>3</sup> ]	130	150	170	190	210	130	150	170	190	210	130	150	170	190	210	
DISPLACEMENT [DM <sup>3</sup> ]	193	218	238	258	278	193	218	238	258	278	195	220	240	260	280	
WEIGHT [KG]	280	285	290	295	300	290	295	300	305	310	300	305	310	315	320	

DATE	NAME	DOCUMENT NO.
DFTR. 18.12.2015	RAEDLINGER	SED 2312716 001 01
CHKD. 01.12.2015	TKBIRKMAN	SCALE
STAND. 01.12.2015	PRODASTSCHUK	1:10
		CHANGE NO.
		1069171

DIMENSION IN mm EXCEPT AS NOTED



ON-LOAD TAP-CHANGER VACUTAP® VM  
 VM I 351/501/651 - B/C/D/DE - 0/W/G  
 DIMENSION DRAWING

SERIAL NUMBER

MATERIAL NUMBER 7462211E SHEET 1/1

© MASCHINENFABRIK REINHAUSEN GMBH 2015  
 THE REPRODUCTION, DISTRIBUTION AND UTILIZATION OF THIS DOCUMENT AS WELL AS THE COMMUNICATION OF ITS CONTENTS TO OTHERS WITHOUT EXPRESS AUTHORIZATION IS PROHIBITED. OFFENDERS WILL BE HELD LIABLE FOR THE PAYMENT OF DAMAGES. ALL RIGHTS RESERVED IN THE EVENT OF THE GRANT OF A PATENT, UTILITY MODEL OR DESIGN.

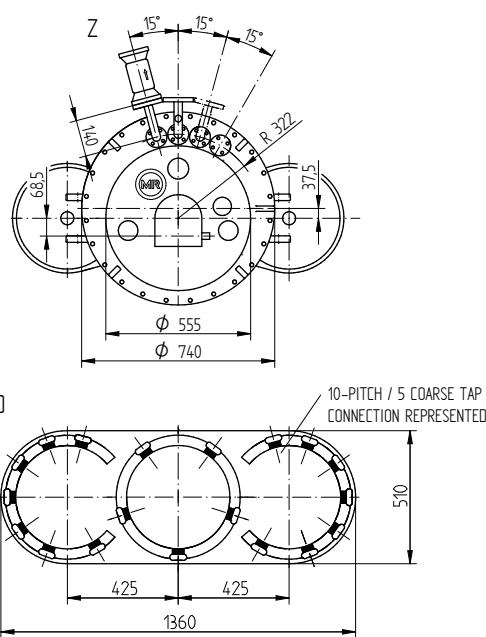
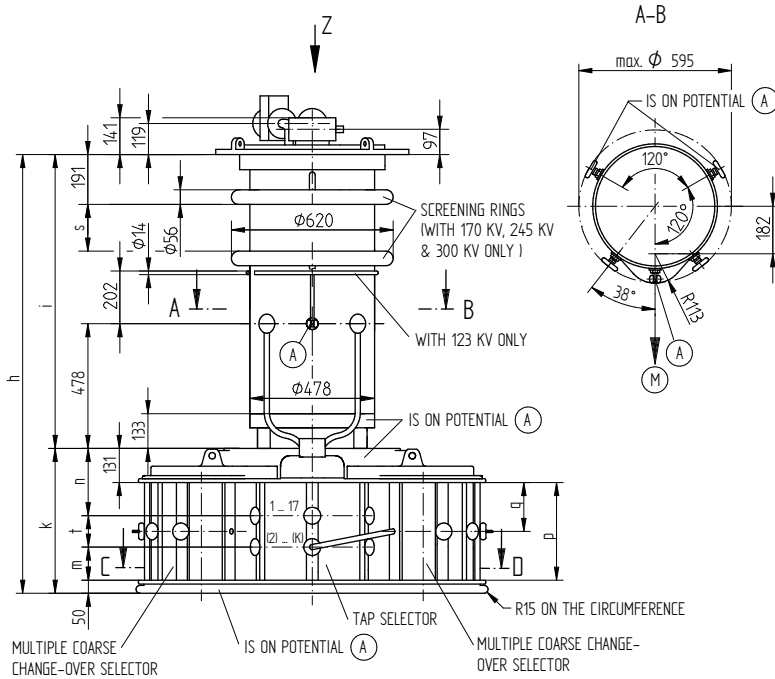

ARRANGEMENT OF SELECTOR CONTACTS, 2-5 COARSE TAP CONNECTIONS (PLAN VIEW)

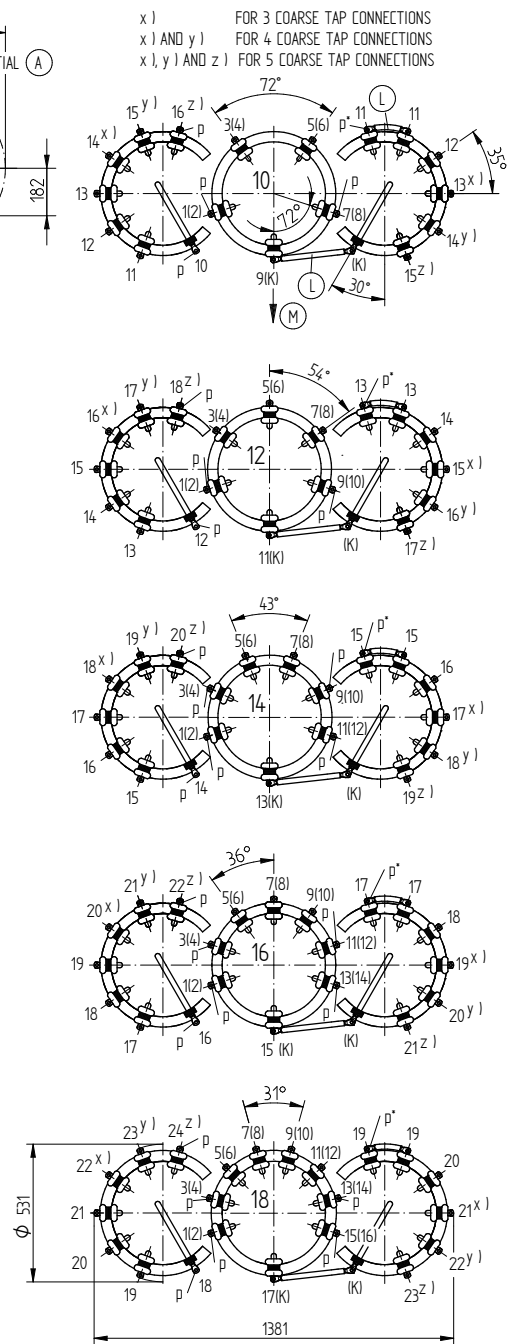

DOCUMENT NO.	SED 2315/40 001 02
NAME	RAEDLINGER
DATE	18.12.2015
SCALE	1:10
CHANGE NO.	TKBRKMANN
DFTR.	01.12.2015
CHKD.	1069171
STAND.	01.12.2015
PRODASTSCHUK	

p = CONNECTION MIN. 3 MM PAPER INSULATED  
 p\* = CONNECTION ALREADY 3 MM PAPER INSULATED BY MR

FOR BINDING DESIGNATIONS OF TERMINALS AND PHASES REFER TO THE CONNECTION DIAGRAM OF THE ON-LOAD TAP-CHANGER.

- (A) ON-LOAD TAP-CHANGER TAKE-OFF LEAD
- (L) CONNECTING LEAD
- (M) DRIVE SIDE OF SELECTOR

SELECTOR SIZE	B					C					D					
U <sub>M</sub> [KV]	72,5	123	170	245	300	72,5	123	170	245	300	72,5	123	170	245	300	
DIMENSIONS [MM]	h	1476	1606	1736	1836	1988	1551	1681	1811	1911	2063	1746	1876	2006	2106	2258
	i	996	1126	1256	1356	1508	996	1126	1256	1356	1508	996	1126	1256	1356	1508
	s	-	-	267	367	520	-	-	267	367	520	-	-	267	367	520
	k	-	-	480	-	-	-	-	555	-	-	-	-	750	-	-
	n	-	-	233	-	-	-	-	258	-	-	-	-	323	-	-
	m	-	-	102	-	-	-	-	127	-	-	-	-	192	-	-
	t	-	-	95	-	-	-	-	120	-	-	-	-	185	-	-
	q	-	-	149,5	-	-	-	-	187	-	-	-	-	284,5	-	-
	p	-	-	299	-	-	-	-	374	-	-	-	-	569	-	-
	OIL VOLUME [DM <sup>3</sup> ]	130	150	170	190	210	130	150	170	190	210	130	150	170	190	210
DISPLACEMENT [DM <sup>3</sup> ]	198	223	243	263	283	198	223	243	263	283	203	223	248	268	288	
WEIGHT [KG]	370	375	380	385	390	380	385	390	395	400	390	395	400	405	410	

DIMENSION IN mm EXCEPT AS NOTED



**ON-LOAD TAP-CHANGER VACUTAP® VM**  
 VM I 651 - B/C/D WITH MULTIPLE COARSE CHANGE-OVER SELECTOR  
 DIMENSION DRAWING

SERIAL NUMBER

MATERIAL NUMBER 7462271E  
 SHEET 1/1

© MASCHINENFABRIK REINHAUSEN GMBH 2015  
 THE REPRODUCTION, DISTRIBUTION AND UTILIZATION OF THIS DOCUMENT AS WELL AS THE COMMUNICATION OF ITS CONTENTS TO OTHERS WITHOUT EXPRESS AUTHORIZATION IS PROHIBITED. OFFENDERS WILL BE HELD LIABLE FOR THE PAYMENT OF DAMAGES. ALL RIGHTS RESERVED IN THE EVENT OF THE GRANT OF A PATENT, UTILITY MODEL OR DESIGN.

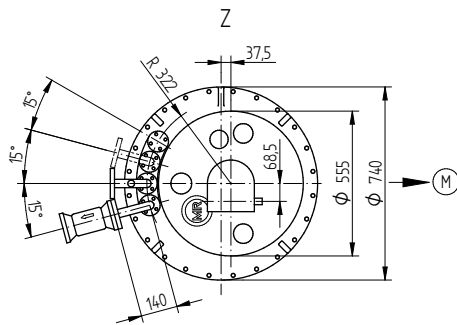
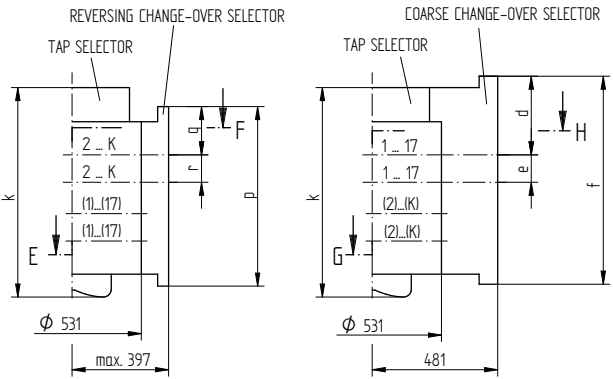
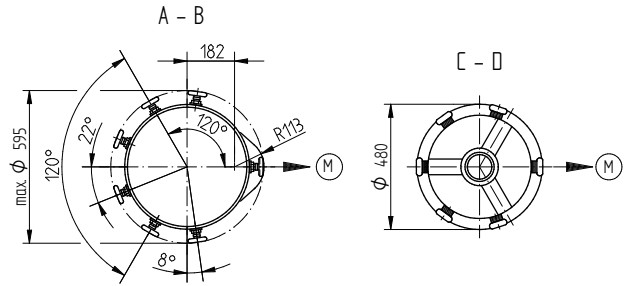
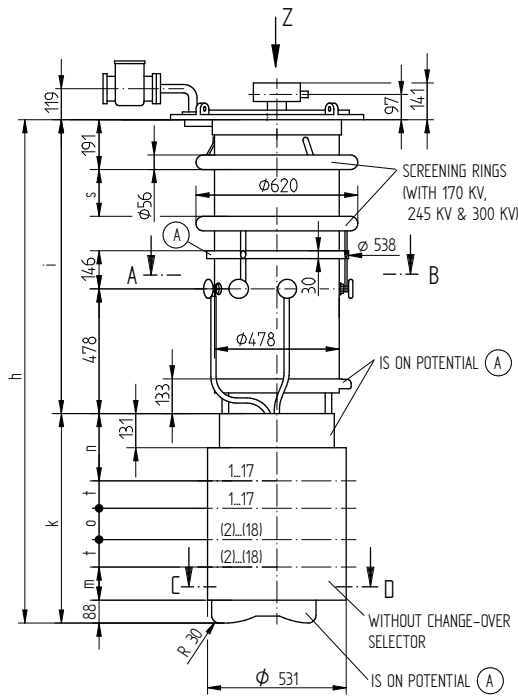

E - F  
REFER TO 723590

G - H  
REFER TO 723590

FOR INHERENT DRAWINGS REFER TO 898012

- (A) ON-LOAD TAP-CHANGER TAKE-OFF TERMINAL
- (M) DRIVE SIDE OF SELECTOR

FOR BINDING DESIGNATIONS OF TERMINALS AND PHASES REFER TO THE CONNECTION DIAGRAM OF THE ON-LOAD TAP-CHANGER.

SELECTOR SIZE	B					C					D / DE				
$U_m$ [KV]	72,5	123	170	245	300	72,5	123	170	245	300	72,5	123	170	245	300
h	1724	1854	1984	2084	2236	1799	1929	2059	2159	2311	1994	2124	2254	2354	2506
i	996	1126	1256	1356	1508	996	1126	1256	1356	1508	996	1126	1256	1356	1508
s	-		267	367	520	-		267	367	520	-		267	367	520
k						803					998				
n						258					323				
o						120					185				
m						127					192				
t						105					105				
r						105					105				
q						185					250				
p						688					883				
e						105					105				
d						3015					3665				
f						797					992				
OIL VOLUME [DM <sup>3</sup> ]	130	150	170	190	210	130	150	170	190	210	130	150	170	190	210
DISPLACEMENT [DM <sup>3</sup> ]	196	221	241	261	281	196	221	241	261	281	199	224	244	264	284
WEIGHT [KG]	310	315	320	325	330	320	325	330	335	340	330	335	340	345	350

DATE	NAME	DOCUMENT NO.
18.12.2015	RAEDLINGER	SED 2312691 001 02
01.12.2015	TKBIRKMAN	CHANGE NO.
01.12.2015	PRODASTSCHUK	1069171
SCALE	1:10	

DIMENSION IN mm EXCEPT AS NOTED



ON-LOAD TAP-CHANGER VACUTAP® VM  
 VM I 802/1002 - B/C/D/DE - O/W/G  
 DIMENSION DRAWING

SERIAL NUMBER

MATERIAL NUMBER  
7462222E

SHEET  
1/1



© MASCHINENFABRIK REINHAUSEN GMBH 2015  
 THE REPRODUCTION, DISTRIBUTION AND UTILIZATION OF THIS DOCUMENT AS WELL AS THE COMMUNICATION OF ITS CONTENTS TO OTHERS WITHOUT EXPRESS AUTHORIZATION IS PROHIBITED. OFFENDERS WILL BE HELD LIABLE FOR THE PAYMENT OF DAMAGES. ALL RIGHTS RESERVED IN THE EVENT OF THE GRANT OF A PATENT, UTILITY MODEL OR DESIGN.

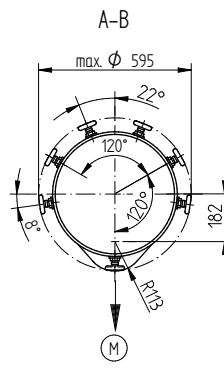
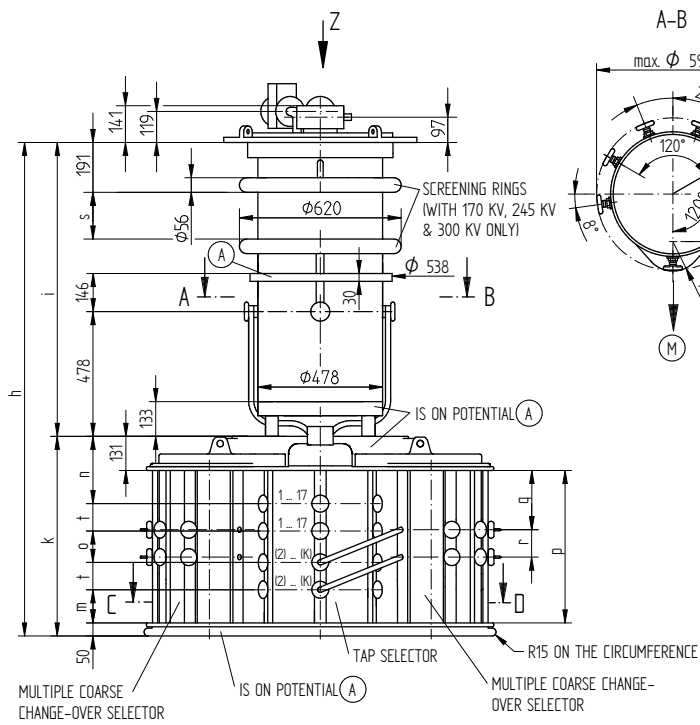

ARRANGEMENT OF SELECTOR CONTACTS, 2-5 COARSE TAP CONNECTIONS (PLAN VIEW)

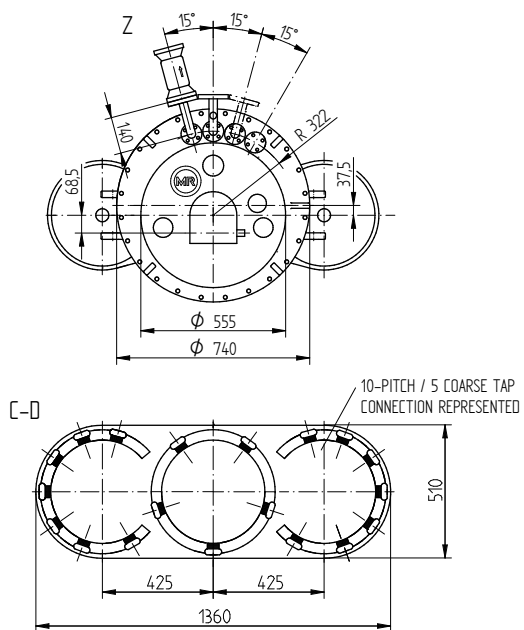
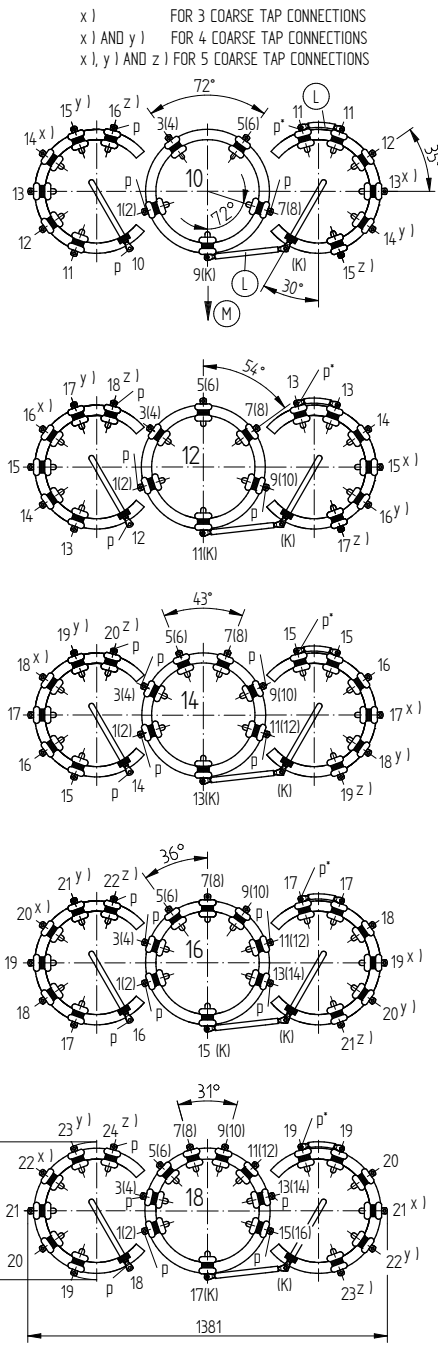

DOCUMENT NO.	SED 23/15/141 001 02
NAME	RAEDLINGER
DATE	18.11.2015
SCALE	1:10
CHANGE NO.	TKBRKMMANN
CHKD.	01.12.2015
PRODASTSCHUK	1069171
STAND.	01.12.2015

p = CONNECTION MIN. 3 MM PAPER INSULATED  
 p' = CONNECTION ALREADY 3 MM PAPER INSULATED BY MR

FOR BINDING DESIGNATIONS OF TERMINALS AND PHASES REFER TO THE CONNECTION DIAGRAM OF THE ON-LOAD TAP-CHANGER.

- (A) ON-LOAD TAP-CHANGER TAKE-OFF TERMINAL
- (L) CONNECTING LEAD
- (M) DRIVE SIDE OF SELECTOR

SELECTOR SIZE	B					C					D					
U <sub>M</sub> [KV]	72,5	123	170	245	300	72,5	123	170	245	300	72,5	123	170	245	300	
DIMENSIONS [MM]	h	1686	1816	1946	2046	2198	1761	1891	2021	2121	2273	1956	2086	2216	2316	2468
	i	996	1126	1256	1356	1508	996	1126	1256	1356	1508	996	1126	1256	1356	1508
	s	-	-	267	367	520	-	-	267	367	520	-	-	267	367	520
	k	-	-	690	-	-	-	-	765	-	-	-	-	960	-	-
	n	-	-	233	-	-	-	-	258	-	-	-	-	323	-	-
	o	-	-	95	-	-	-	-	120	-	-	-	-	185	-	-
	m	-	-	102	-	-	-	-	127	-	-	-	-	192	-	-
	t	-	-	105	-	-	-	-	105	-	-	-	-	105	-	-
	r	-	-	105	-	-	-	-	105	-	-	-	-	105	-	-
	q	-	-	189,5	-	-	-	-	227	-	-	-	-	324,5	-	-
	p	-	-	509	-	-	-	-	584	-	-	-	-	779	-	-
	OIL VOLUME [DM <sup>3</sup> ]	130	150	170	190	210	130	150	170	190	210	130	150	170	190	210
DISPLACEMENT [DM <sup>3</sup> ]	200	225	245	265	285	200	225	245	265	285	208	233	253	273	293	
WEIGHT [KG]	410	415	420	425	430	420	425	430	435	440	430	435	440	445	450	

DIMENSION IN mm EXCEPT AS NOTED



**ON-LOAD TAP-CHANGER VACUTAP® VM**  
 VM I 802/1002 - B/C/D WITH MULTIPLE COARSE C.-O. SELECTOR  
 DIMENSION DRAWING

SERIAL NUMBER	
MATERIAL NUMBER	SHEET
7462282E	1/1

© MASCHINENFABRIK REINHAUSEN GMBH 2015  
 THE REPRODUCTION, DISTRIBUTION AND UTILIZATION OF THIS DOCUMENT AS WELL AS THE COMMUNICATION OF ITS CONTENTS TO OTHERS WITHOUT EXPRESS AUTHORIZATION IS PROHIBITED. OFFENDERS WILL BE HELD LIABLE FOR THE PAYMENT OF DAMAGES. ALL RIGHTS RESERVED IN THE EVENT OF THE GRANT OF A PATENT, UTILITY MODEL OR DESIGN.

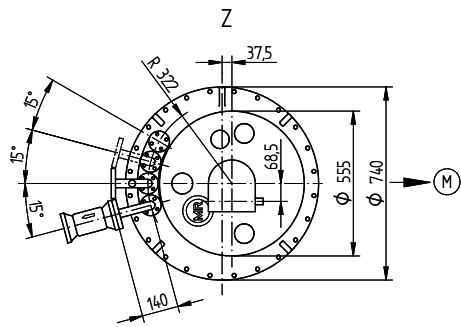
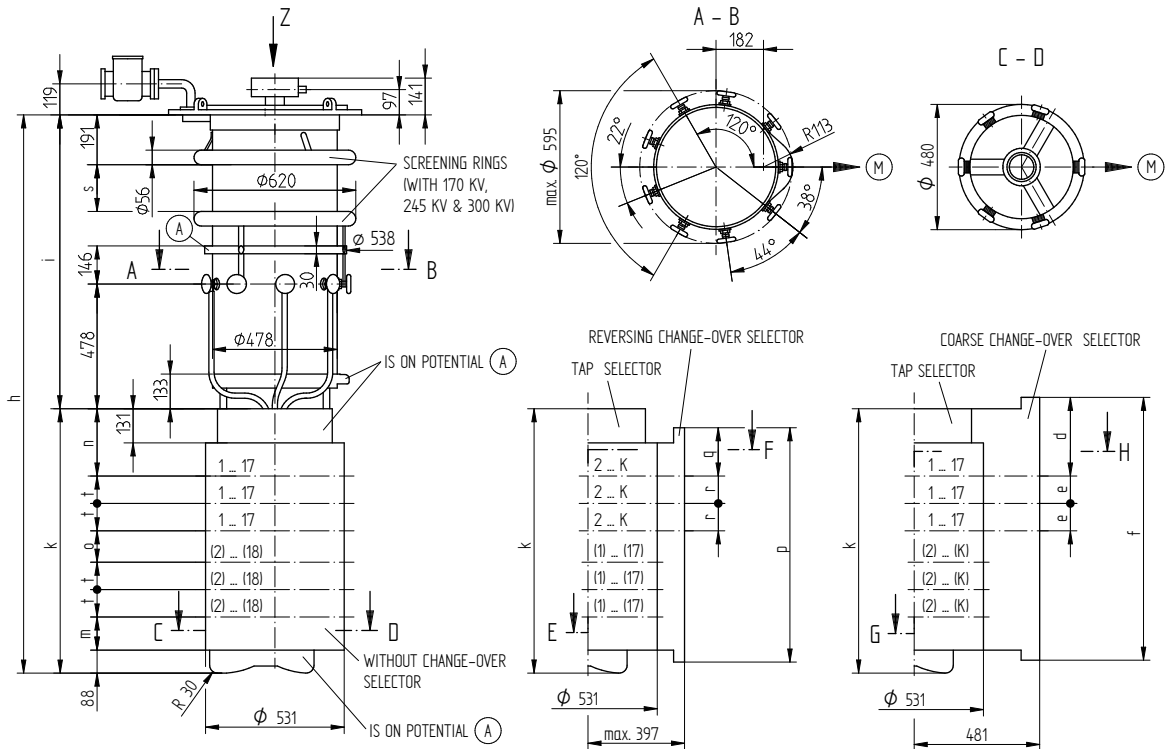

E - F  
 REFER TO 723590

G - H  
 REFER TO 723590

FOR INHERENT DRAWINGS REFER TO 898012

- (A) ON-LOAD TAP-CHANGER TAKE-OFF TERMINAL
- (M) DRIVE SIDE OF SELECTOR

FOR BINDING DESIGNATIONS OF TERMINALS AND PHASES REFER TO THE CONNECTION DIAGRAM OF THE ON-LOAD TAP-CHANGER.

DATE	NAME	DOCUMENT NO.
DFTR. 18.11.2015	RAEDLINGER	SED 2313229 001 01
CHKD. 01.12.2015	TKBIRKMAN	CHANGE NO.
STAND. 01.12.2015	PRODASTSCHUK	1069171
		SCALE 1:10

SELECTOR SIZE	B					C					D/DE				
	72,5	123	170	245	300	72,5	123	170	245	300	72,5	123	170	245	300
$U_m$ [KV]	72,5	123	170	245	300	72,5	123	170	245	300	72,5	123	170	245	300
h	1934	2064	2194	2294	2446	2009	2139	2269	2369	2521	2204	2334	2464	2564	2716
i	996	1126	1256	1356	1508	996	1126	1256	1356	1508	996	1126	1256	1356	1508
s	-	267	367	520		-	267	367	520		-	267	367	520	
k		938					1013					1208			
n		233					258					323			
o		95					120					185			
m		102					127					192			
t		105					105					105			
r		105					105					105			
q		160					185					250			
p		823					898					1093			
e		105					105					105			
d		276.5					301.5					366.5			
f		932					1007					1202			
OIL VOLUME [DM <sup>3</sup> ]	130	150	170	190	210	130	150	170	190	210	130	150	170	190	210
DISPLACEMENT [DM <sup>3</sup> ]	200	225	245	265	285	200	225	245	265	285	204	229	249	269	289
WEIGHT [KG]	350	355	360	365	370	360	365	370	375	380	375	380	385	390	395

DIMENSION IN mm EXCEPT AS NOTED



ON-LOAD TAP-CHANGER VACUTAP® VM  
 VM I 1203/1503 - B/C/D/DE - O/W/G  
 DIMENSION DRAWING

SERIAL NUMBER

MATERIAL NUMBER 7462231E SHEET 1/1



© MASCHINENFABRIK REINHAUSEN GMBH 2015  
 THE REPRODUCTION, DISTRIBUTION AND UTILIZATION OF THIS DOCUMENT AS WELL AS THE COMMUNICATION OF ITS CONTENTS TO OTHERS WITHOUT EXPRESS AUTHORIZATION IS PROHIBITED. OFFENDERS WILL BE HELD LIABLE FOR THE PAYMENT OF DAMAGES. ALL RIGHTS RESERVED IN THE EVENT OF THE GRANT OF A PATENT, UTILITY MODEL OR DESIGN.

DATE	NAME	DOCUMENT NO.
DFTR. 18.11.2015	RAEDLINGER	SED 2310512 001 01
CHKD. 01.12.2015	TKBIRKMAN	CHANGE NO.
STAND. 01.12.2015	PRODASTSCHUK	1069171
	SCALE	1:10

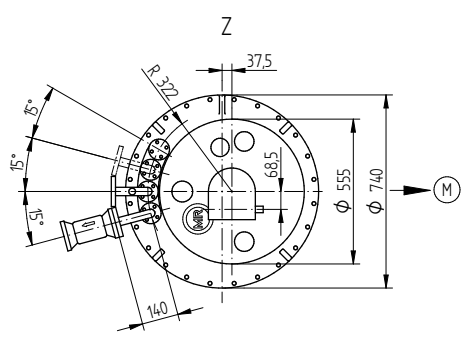
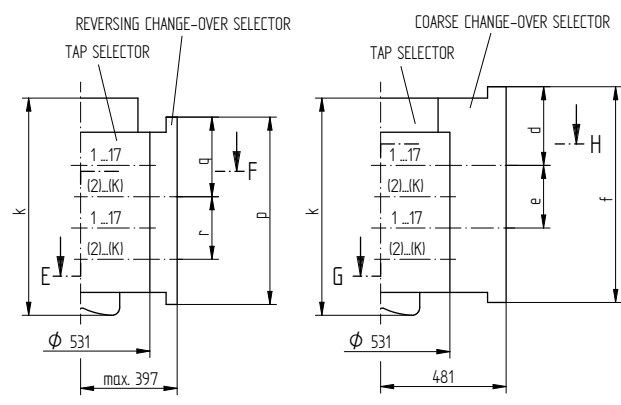
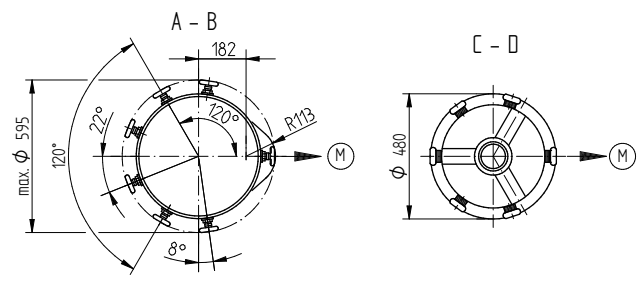
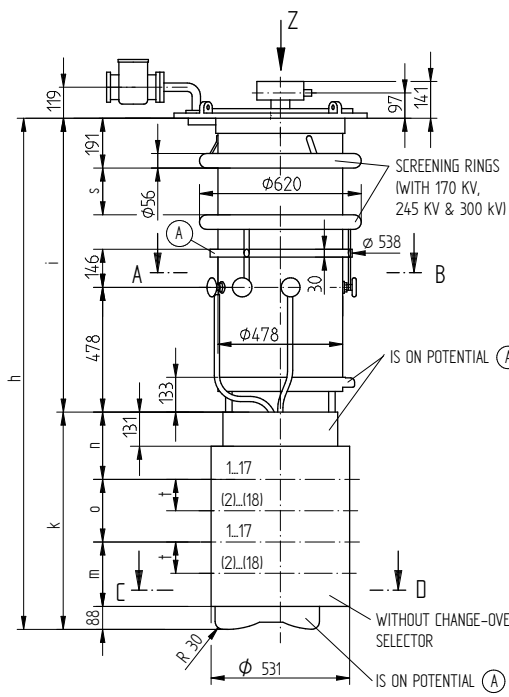

E - F  
REFER TO 723590

G - H  
REFER TO 723590

FOR INHERENT DRAWINGS REFER TO 898012

- (A) ON-LOAD TAP-CHANGER TAKE-OFF TERMINAL (NEUTRAL)
- (M) DRIVE SIDE OF SELECTOR

FOR BINDING DESIGNATIONS OF TERMINALS AND PHASES REFER TO THE CONNECTION DIAGRAM OF THE ON-LOAD TAP-CHANGER.

SELECTOR SIZE	B					C					D / DE					
	72,5	123	170	245	300	72,5	123	170	245	300	72,5	123	170	245	300	
$U_m$ [ kV ]	72,5	123	170	245	300	72,5	123	170	245	300	72,5	123	170	245	300	
DIMENSIONS [MM]	h	1704	1834	1964	2064	2216	1829	1959	2089	2189	2341	2154	2284	2414	2514	2666
	i	996	1126	1256	1356	1508	996	1126	1256	1356	1508	996	1126	1256	1356	1508
	s	-	-	267	367	520	-	-	267	367	520	-	-	267	367	520
	k	-	-	708	-	-	-	-	833	-	-	-	-	1158	-	-
	n	-	-	233	-	-	-	-	258	-	-	-	-	323	-	-
	o	-	-	190	-	-	-	-	240	-	-	-	-	370	-	-
	m	-	-	197	-	-	-	-	247	-	-	-	-	377	-	-
	t	-	-	95	-	-	-	-	120	-	-	-	-	185	-	-
	r	-	-	190	-	-	-	-	240	-	-	-	-	370	-	-
	q	-	-	255	-	-	-	-	305	-	-	-	-	435	-	-
	p	-	-	593	-	-	-	-	718	-	-	-	-	1043	-	-
	e	-	-	190	-	-	-	-	240	-	-	-	-	370	-	-
	d	-	-	276,5	-	-	-	-	301,5	-	-	-	-	366,5	-	-
f	-	-	702	-	-	-	-	827	-	-	-	-	1152	-	-	
OIL VOLUME [DM <sup>3</sup> ]	130	150	170	190	210	130	150	170	190	210	130	150	170	190	210	
DISPLACEMENT [DM <sup>3</sup> ]	196	221	241	261	281	196	221	241	261	281	199	224	244	264	284	
MAX. WEIGHT [KG]	310	315	320	325	330	320	325	330	335	340	330	335	340	345	350	

DIMENSION IN mm EXCEPT AS NOTED



ON-LOAD TAP-CHANGER VACUTAP® VM  
 VM II 352/502/652 - B/C/D/DE - O/W/G  
 DIMENSION DRAWING

SERIAL NUMBER	
MATERIAL NUMBER	SHEET
7462201E	1/1

© MASCHINENFABRIK REINHAUSEN GMBH 2018  
 THE REPRODUCTION, DISTRIBUTION AND UTILIZATION OF THIS DOCUMENT AS WELL AS THE COMMUNICATION OF ITS CONTENTS TO OTHERS WITHOUT EXPRESS AUTHORIZATION IS PROHIBITED. OFFENDERS WILL BE HELD LIABLE FOR THE PAYMENT OF DAMAGES. ALL RIGHTS RESERVED IN THE EVENT OF A PATENT, UTILITY MODEL OR DESIGN.

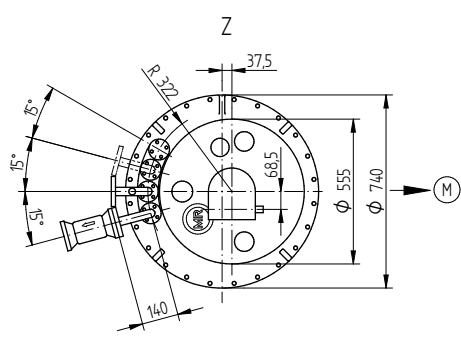
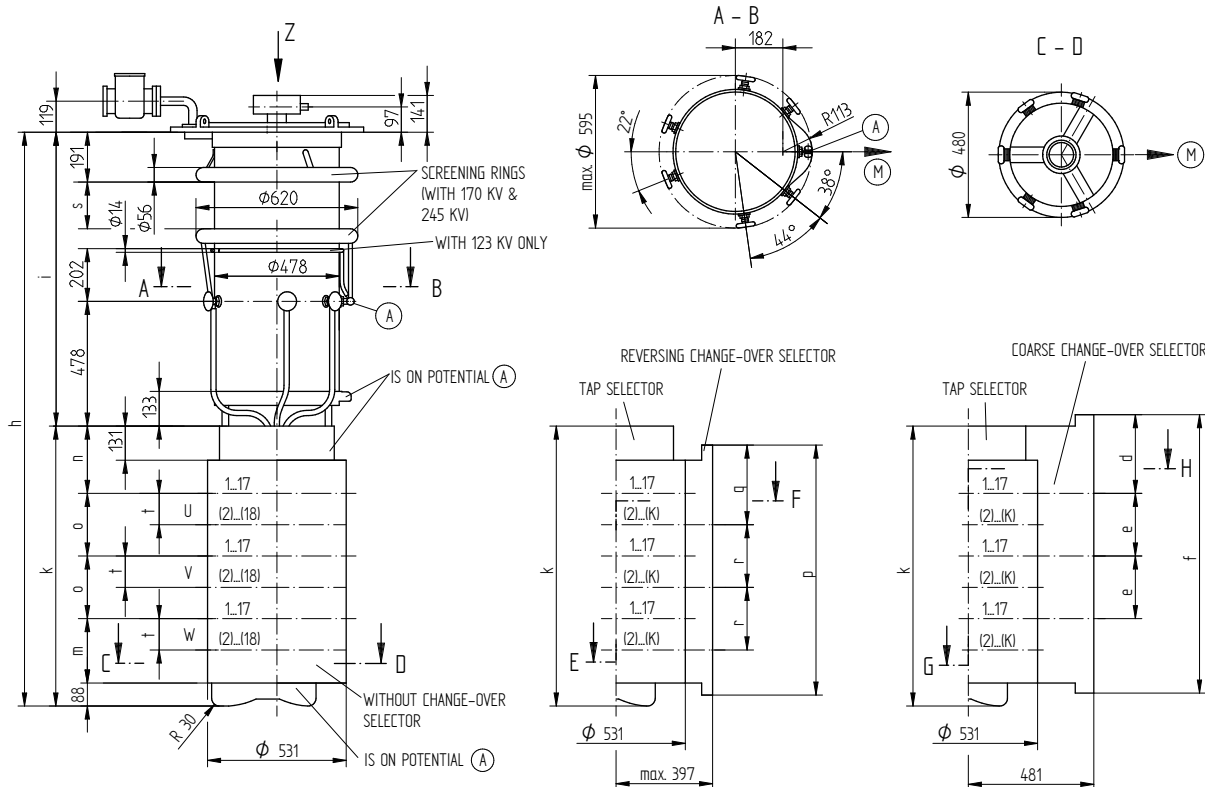

E - F  
 REFER TO 723590

G - H  
 REFER TO 723590

FOR INHERENT DRAWINGS REFER TO 898012

(A) ON-LOAD TAP-CHANGER TAKE-OFF LEAD (NEUTRAL)  
 (M) DRIVE SIDE OF SELECTOR

FOR BINDING DESIGNATIONS OF TERMINALS AND PHASES REFER TO THE CONNECTION DIAGRAM OF THE ON-LOAD TAP-CHANGER.

SELECTOR SIZE	B				C *)				D / DE				
	72,5	123	170	245	72,5 <sup>1)</sup>	123 <sup>1)</sup>	170 <sup>1)</sup>	245	72,5	123	170	245	
U <sub>m</sub> [ kV ]													
DIMENSIONS [MM]	h	1894	2024	2154	2254	2069	2199	2329	2429	2524	2654	2784	2884
	i	996	1126	1256	1356	996	1126	1256	1356	996	1126	1256	1356
	s	-	-	267	367	-	-	267	367	-	-	267	367
	k	-	898	-	-	-	-	1073	-	-	-	1528	-
	n	-	233	-	-	-	-	258	-	-	-	323	-
	o	-	190	-	-	-	-	240	-	-	-	370	-
	m	-	197	-	-	-	-	247	-	-	-	377	-
	t	-	95	-	-	-	-	120	-	-	-	185	-
	r	-	190	-	-	-	-	240	-	-	-	370	-
	q	-	255	-	-	-	-	305	-	-	-	435	-
	p	-	783	-	-	-	-	958	-	-	-	1413	-
	d	-	276,5	-	-	-	-	3015	-	-	-	366,5	-
e	-	190	-	-	-	-	240	-	-	-	370	-	
f	-	892	-	-	-	-	1067	-	-	-	1522	-	
OIL VOLUME [DM <sup>3</sup> ]	130	150	170	190	130	150	170	190	130	150	170	190	
DISPLACEMENT [DM <sup>3</sup> ]	199	224	244	264	199	224	244	264	207	232	252	272	
MAX. WEIGHT [KG]	350	355	360	365	360	365	370	375	375	380	385	390	

\*) VMS® AVAILABLE ONLY IN THESE VERSIONS

DATE	12.07.2018	NAME	BUTERUS	DOCUMENT NO.	SED 2310153 001 02
DFTR.	16.07.2018	CHKD.	WILHELM	CHANGE NO.	1086956
STAND.	16.07.2018	PRODASTSCHUK		SCALE	1:10

DIMENSION  
 IN mm  
 EXCEPT AS  
 NOTED



ON-LOAD TAP-CHANGER VACUTAP® VM®, VMS® - DIMENSION DRAWING  
 VM III 350/500/650 Y - B/C/D/DE - O/W/G  
 VMS III 400/650 Y - C - O/W/G

SERIAL NUMBER	
MATERIAL NUMBER	SHEET
7462192E	1/1

© MASCHINENFABRIK REINHAUSEN GMBH 2015  
 THE REPRODUCTION, DISTRIBUTION AND UTILIZATION OF THIS DOCUMENT AS WELL AS THE COMMUNICATION OF ITS CONTENTS TO OTHERS WITHOUT EXPRESS AUTHORIZATION IS PROHIBITED. OFFENDERS WILL BE HELD LIABLE FOR THE PAYMENT OF DAMAGES. ALL RIGHTS RESERVED IN THE EVENT OF THE GRANT OF A PATENT, UTILITY MODEL OR DESIGN.

## VM I 351 / 501 / 651 - 0 / W / G

SELECTOR SIZE		B					C					D/DE					
Um IN KV		72.5	123	170	245	300	72.5	123	170	245	300	72.5	123	170	245	300	
DIMENSIONS IN MM	h	1514	1644	1774	1874	2026	1589	1719	1849	1949	2101	1784	1914	2044	2144	2296	
	i	996	1126	1256	1356	1508	996	1126	1256	1356	1508	996	1126	1256	1356	1508	
	s	-	267	367	520	-	267	367	520	-	267	367	520	-	267	367	520
	k	-	-	518	-	-	-	593	-	-	788	-	-	833	-	-	1158
	n	-	-	233	-	-	-	258	-	-	323	-	-	258	-	-	323
	m	-	-	102	-	-	-	127	-	-	192	-	-	240	-	-	370
	t	-	-	95	-	-	-	120	-	-	185	-	-	240	-	-	377
	q	-	-	160	-	-	-	185	-	-	250	-	-	305	-	-	435
	p	-	-	403	-	-	-	478	-	-	673	-	-	718	-	-	1043
	d	-	-	2765	-	-	-	3015	-	-	3665	-	-	3015	-	-	3665
f	-	-	512	-	-	-	587	-	-	782	-	-	827	-	-	1152	
OIL VOLUME	DM³	130	150	170	190	210	130	150	170	190	210	130	150	170	190	210	
DISPLACEMENT	DM³	193	218	238	258	278	193	218	238	258	278	195	220	240	260	280	
WEIGHT	KG	280	285	290	295	300	290	295	300	305	310	300	305	310	315	320	

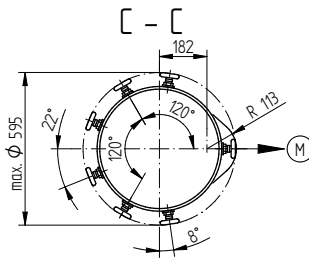
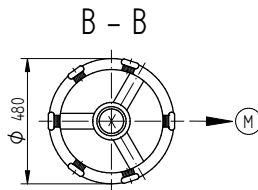
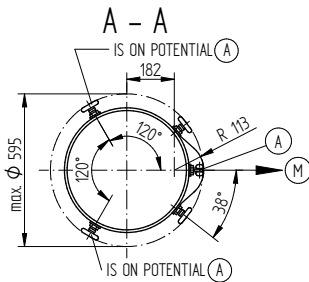
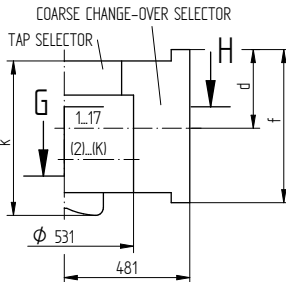
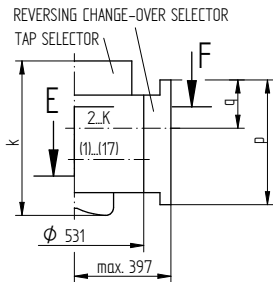
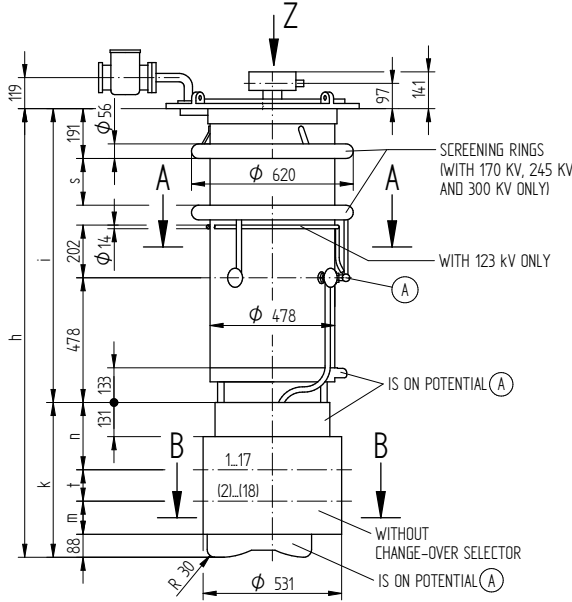

FOR INHERENT DRAWINGS REFER TO 898012

- (A) ON-LOAD TAP-CHANGER TAKE-OFF LEAD
- (M) DRIVE SIDE OF SELECTOR

FOR BINDING DESIGNATIONS OF TERMINALS AND PHASES REFER TO THE CONNECTION DIAGRAM OF THE ON-LOAD TAP-CHANGER.

## VM II 352 / 502 / 652 - 0 / W / G

SELECTOR SIZE		B					C					D/DE					
Um IN KV		72.5	123	170	245	300	72.5	123	170	245	300	72.5	123	170	245	300	
DIMENSIONS IN MM	h	1704	1834	1964	2064	2216	1829	1959	2089	2189	2341	2154	2284	2414	2514	2666	
	i	996	1126	1256	1356	1508	996	1126	1256	1356	1508	996	1126	1256	1356	1508	
	s	-	267	367	520	-	267	367	520	-	267	367	520	-	267	367	520
	k	-	-	708	-	-	-	833	-	-	1158	-	-	1158	-	-	1518
	n	-	-	233	-	-	-	258	-	-	323	-	-	258	-	-	323
	o	-	-	190	-	-	-	240	-	-	370	-	-	240	-	-	370
	m	-	-	197	-	-	-	247	-	-	377	-	-	247	-	-	377
	t	-	-	95	-	-	-	120	-	-	185	-	-	120	-	-	185
	r	-	-	190	-	-	-	240	-	-	370	-	-	240	-	-	370
	q	-	-	255	-	-	-	305	-	-	435	-	-	305	-	-	435
p	-	-	593	-	-	-	718	-	-	1043	-	-	718	-	-	1043	
e	-	-	190	-	-	-	240	-	-	370	-	-	240	-	-	370	
d	-	-	2765	-	-	-	3015	-	-	3665	-	-	3015	-	-	3665	
f	-	-	702	-	-	-	827	-	-	1152	-	-	827	-	-	1152	
OIL VOLUME	DM³	130	150	170	190	210	130	150	170	190	210	130	150	170	190	210	
DISPLACEMENT	DM³	196	221	241	261	281	196	221	241	261	281	199	224	244	264	284	
WEIGHT	KG	310	315	320	325	330	320	325	330	335	340	330	335	340	345	350	

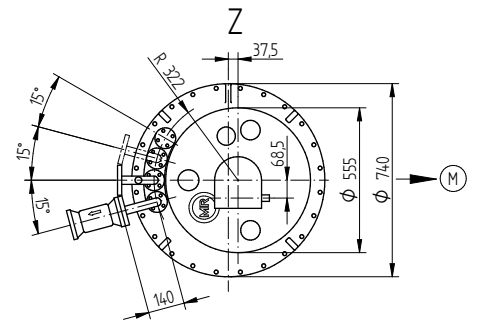
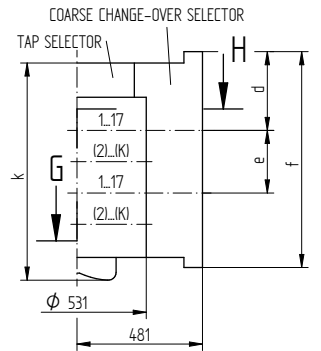
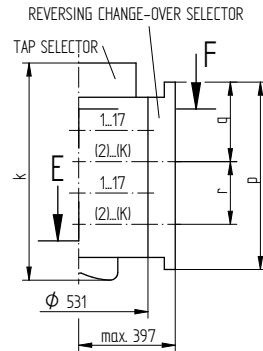
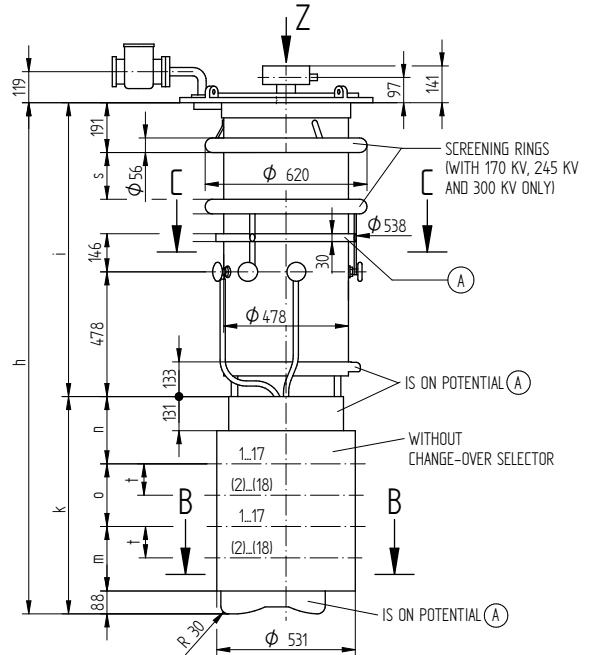

E - F / G - H

REFER TO 723590

DATE	NAME	DOCUMENT NO.
DFTR. 18.11.2015	RAEDLINGER	SED 2315008 001 02
CHKD. 01.12.2015	TKBIRKMAN	CHANGE NO.
STAND. 01.12.2015	PRODATSCHUK	1069171
		SCALE 1:10

DIMENSION IN mm EXCEPT AS NOTED



**ON-LOAD TAP-CHANGER VACUTAP® VM**  
**VM III 350/500/650 K-B/C/D/DE-0/W/G**  
**DIMENSION DRAWING**

SERIAL NUMBER

MATERIAL NUMBER  
**746224-2E**

SHEET  
**1/1**

© MASCHINENFABRIK REINHAUSEN GMBH 2015  
 THE REPRODUCTION, DISTRIBUTION AND UTILIZATION OF THIS DOCUMENT AS WELL AS THE COMMUNICATION OF ITS CONTENTS TO OTHERS WITHOUT EXPRESS AUTHORIZATION IS PROHIBITED. OFFENDERS WILL BE HELD LIABLE FOR THE PAYMENT OF DAMAGES. ALL RIGHTS RESERVED IN THE EVENT OF THE GRANT OF A PATENT, UTILITY MODEL OR DESIGN.

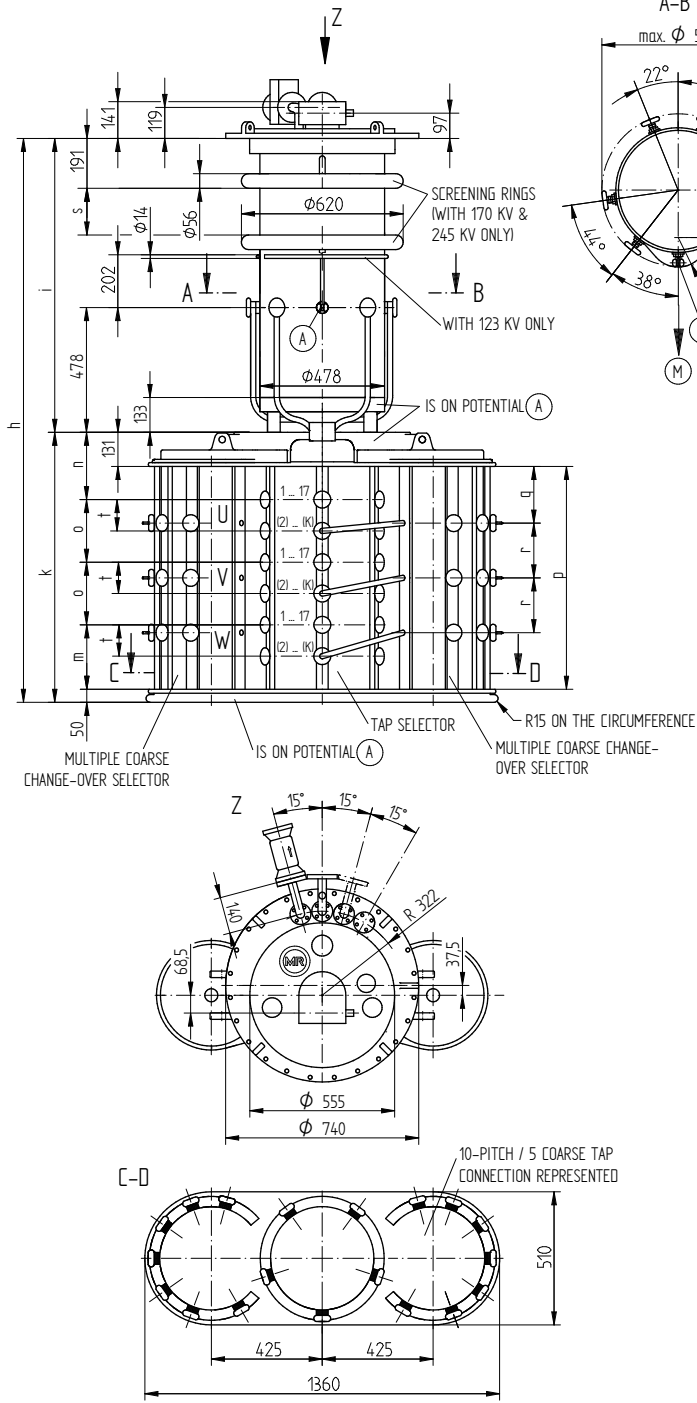

ARRANGEMENT OF SELECTOR CONTACTS, 2-5 COARSE TAP CONNECTIONS (PLAN VIEW)

x ) FOR 3 COARSE TAP CONNECTIONS  
 x ) AND y ) FOR 4 COARSE TAP CONNECTIONS  
 x ), y ) AND z ) FOR 5 COARSE TAP CONNECTIONS

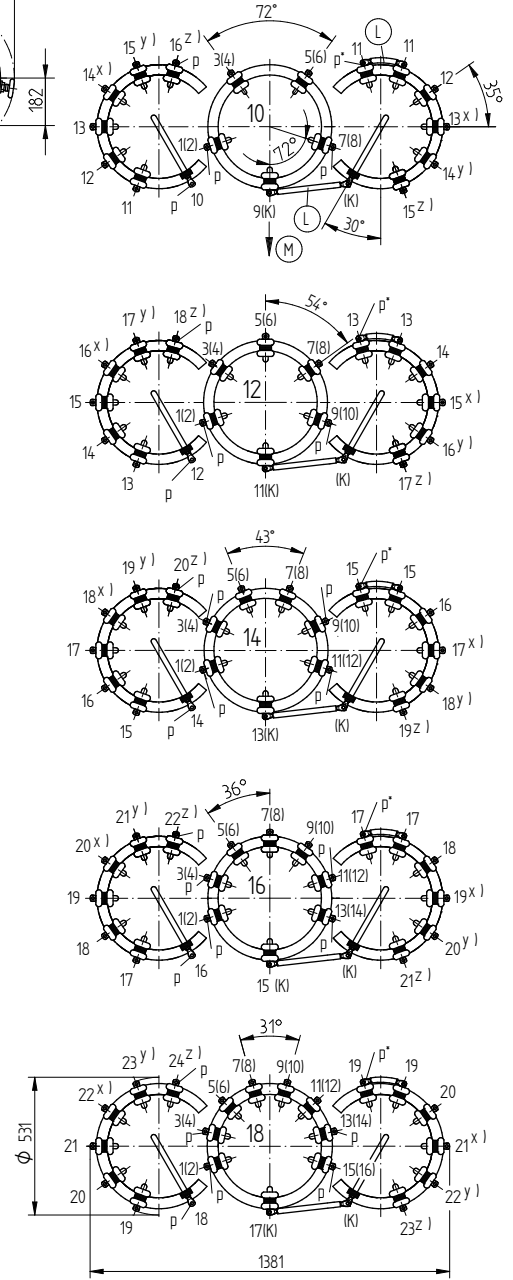

DOCUMENT NO.	SED 2315094_001 02		
NAME	RAEDLINGER	TKBIRKMAN	PRODASTSCHUK
DATE	18.11.2015	01.12.2015	01.12.2015
DFTR.	01.12.2015		
CHKD.			
SCALE	1:10		
CHANGE NO.	1069171		
STAND.			

p = CONNECTION MIN. 3 MM PAPER INSULATED  
 p' = CONNECTION ALREADY 3 MM PAPER INSULATED BY MR

FOR BINDING DESIGNATIONS OF TERMINALS AND PHASES REFER TO THE CONNECTION DIAGRAM OF THE ON-LOAD TAP-CHANGER.

- (A) ON-LOAD TAP-CHANGER TAKE-OFF LEAD
- (L) CONNECTING LEAD
- (M) DRIVE SIDE OF SELECTOR

SELECTOR SIZE	B				C				D			
U <sub>M</sub> [KV]	72,5	123	170	245	72,5	123	170	245	72,5	123	170	245
h	1856	1986	2116	2216	2031	2161	2291	2391	2486	2616	2746	2846
i	996	1126	1256	1356	996	1126	1256	1356	996	1126	1256	1356
s	-		267	367	-		267	367	-		267	367
k	860				1035				1490			
n	233				258				323			
o	190				240				370			
m	197				247				377			
t	95				120				185			
r	166,5				210				327			
q	173				217				327,5			
p	679				854				1309			
OIL VOLUME [DM <sup>3</sup> ]	130	150	170	190	130	150	170	190	130	150	170	190
DISPLACEMENT [DM <sup>3</sup> ]	321	346	366	386	321	346	366	386	333	353	375	395
WEIGHT [KG]	460	465	470	475	470	475	480	485	485	490	495	500

DIMENSION IN mm EXCEPT AS NOTED



ON-LOAD TAP-CHANGER VACUTAP® VM  
 VM III 650 Y - B/C/D WITH MULTIPLE COARSE C.-O. SELECTOR  
 DIMENSION DRAWING

SERIAL NUMBER

MATERIAL NUMBER 7462261E SHEET 1/1

© MASCHINENFABRIK REINHAUSEN GMBH 2018  
 THE REPRODUCTION, DISTRIBUTION AND UTILIZATION OF THIS DOCUMENT AS WELL AS THE COMMUNICATION OF ITS CONTENTS TO OTHERS WITHOUT EXPRESS AUTHORIZATION IS PROHIBITED. OFFENDERS WILL BE HELD LIABLE FOR THE PAYMENT OF DAMAGES. ALL RIGHTS RESERVED IN THE EVENT OF A PATENT, UTILITY MODEL OR DESIGN.

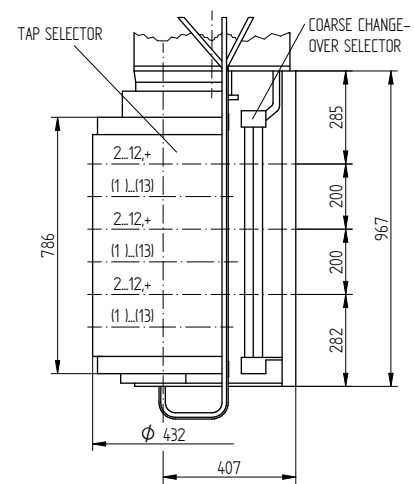
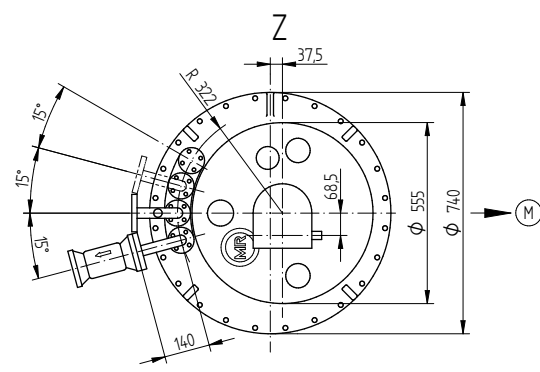
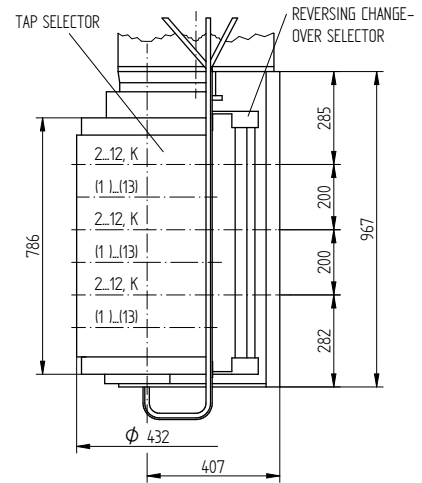
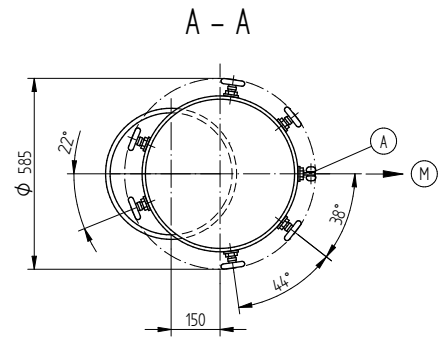
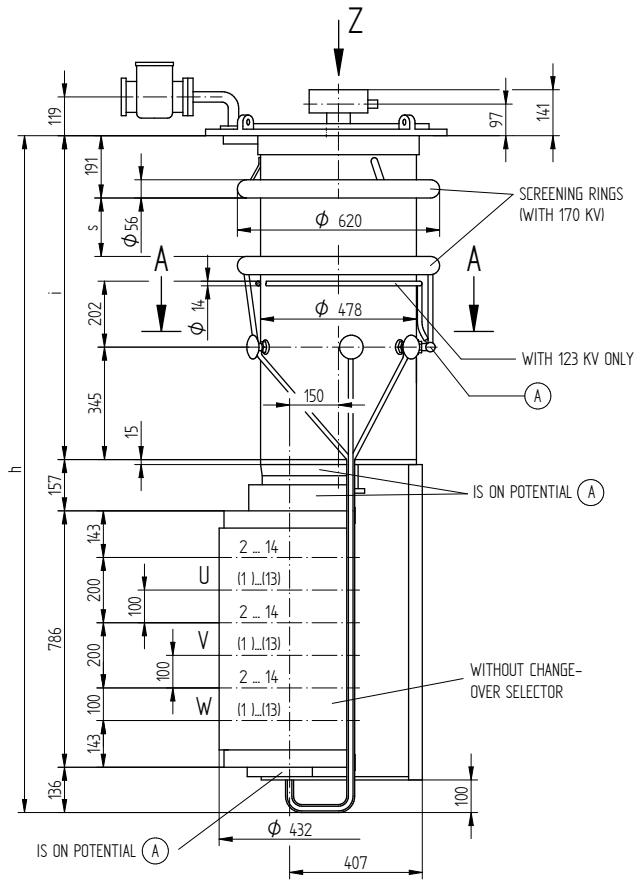

DOCUMENT NO.	SED 6011085 001 00
NAME	BUTERUS WILHELM
DATE	11.07.2018
CHKD.	16.07.2018
SCALE	1:18
CHANGE NO.	1086956
STAND	16.07.2018
	PRODASTSCHUK

FOR INHERENT DRAWINGS REFER TO 898026

- (A) ON-LOAD TAP-CHANGER TAKE-OFF LEAD (NEUTRAL)
- (M) DRIVE SIDE OF SELECTOR

FOR BINDING DESIGNATIONS OF TERMINALS AND PHASES REFER TO THE CONNECTION DIAGRAM OF THE ON-LOAD TAP-CHANGER.

SELECTOR SIZE	B		
$U_M$ [KV]	72,5	123	170
DIMENSIONS [MM]	h	1942	2072
	i	863	993
	s	-	
OIL VOLUME [DM <sup>3</sup> ]	130	150	170
DISPLACEMENT [DM <sup>3</sup> ]	190	220	240
MAX. WEIGHT [KG]	280	285	290

DIMENSION IN mm EXCEPT AS NOTED



ON-LOAD TAP-CHANGER VACUTAP® VMS®  
 VMS III 400 Y - B - 0/W/G  
 DIMENSION DRAWING

SERIAL NUMBER

MATERIAL NUMBER 101165600E  
 SHEET 1/1



© MASCHINENFABRIK REINHAUSEN GMBH 2018  
 Weitergabe sowie Vervielfältigung dieses Dokuments, Verwertung und Mitteilung seines Inhaltes sind verboten, soweit nicht ausdrücklich gestattet.  
 Zuwiderhandlungen verpflichten zu Schadensersatz. Alle Rechte für den Fall der Patent-, Gebrauchsmuster- oder Designeintragung vorbehalten.

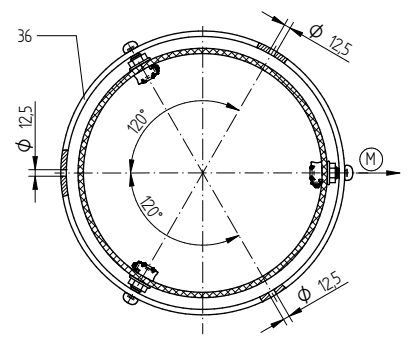
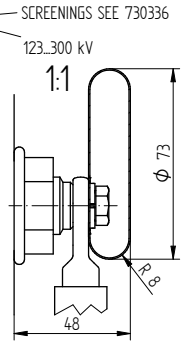
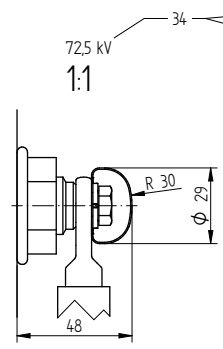
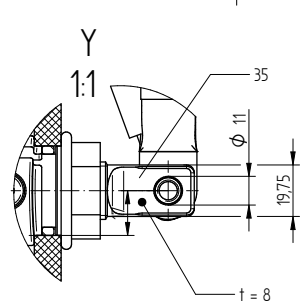
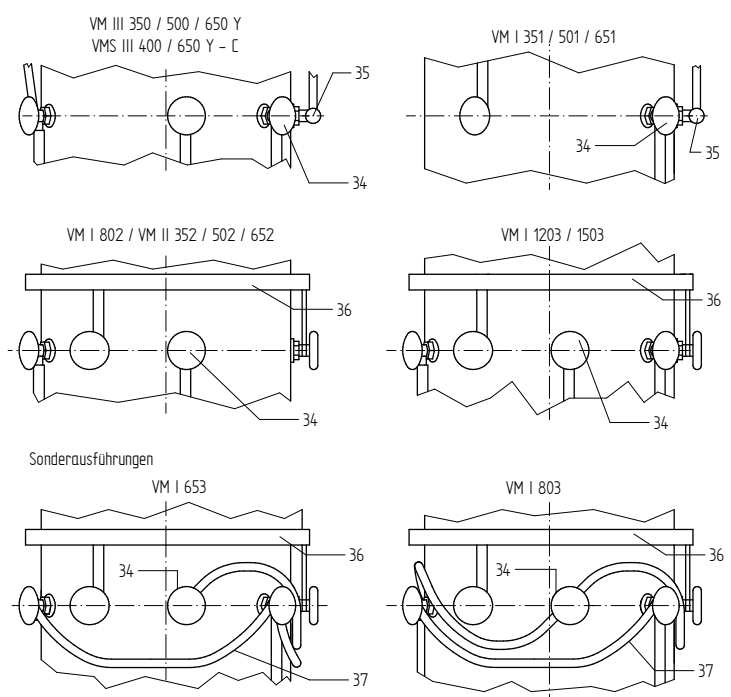
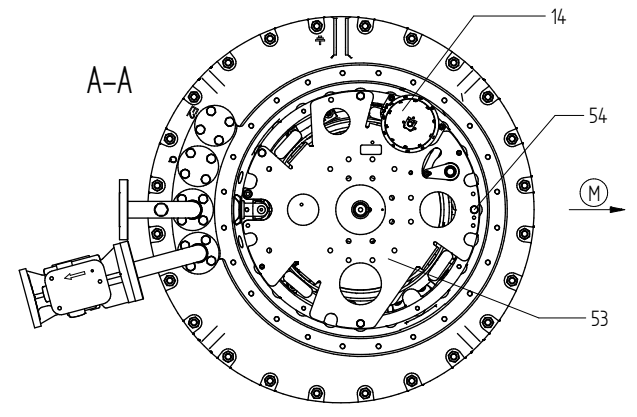
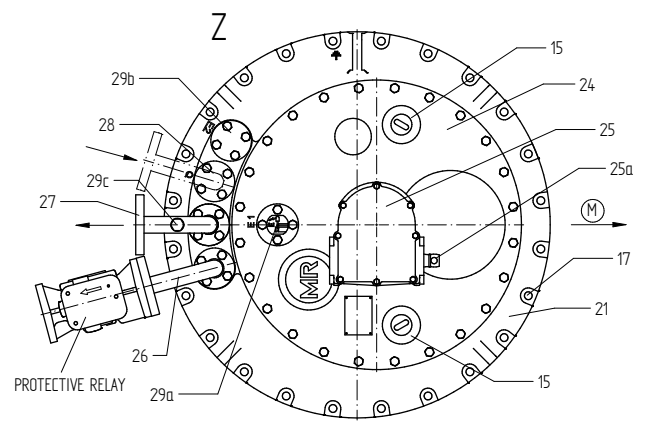
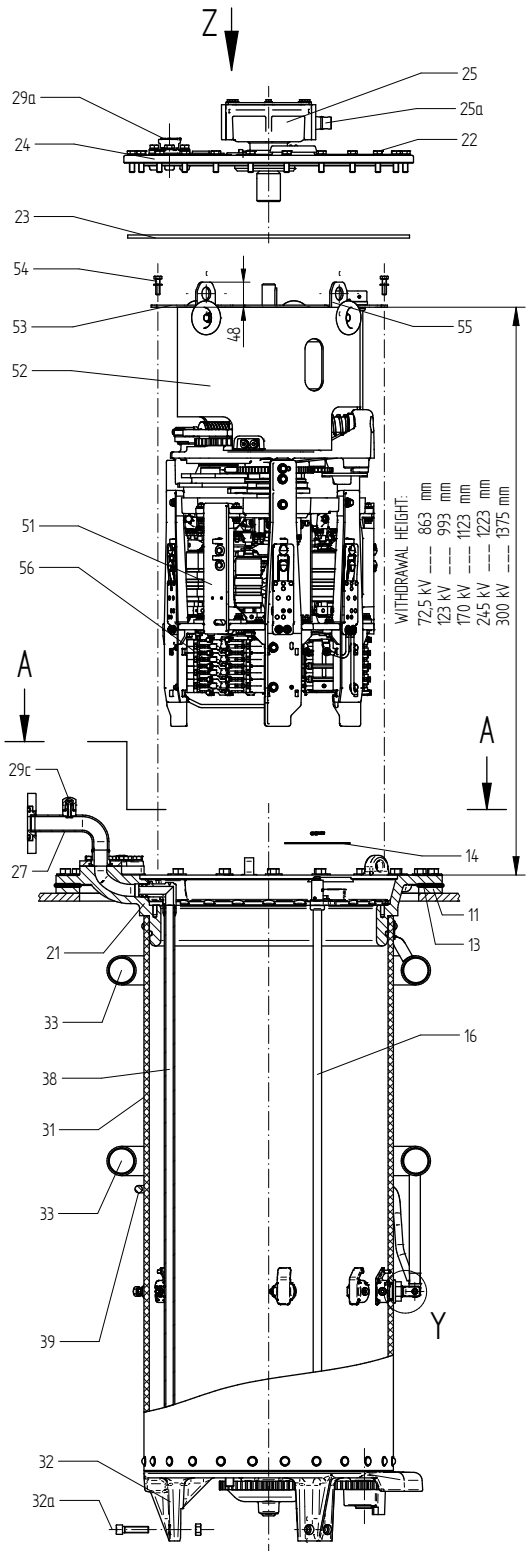

Datum	Name	Dokumentnummer
13.07.2018	BUTERUS	SED 231710 001 03
Gez. bepr.	WILHELM	Änderungsnummer
16.07.2018	PRODASTSCHUK	1086956
Norm.		15

Maßangaben  
 in mm, soweit  
 nicht anders  
 angegeben



ON-LOAD TAP-CHANGER VACUTAP® VM®, VMS®-C  
 M-SELECTOR SIZE B/C/D/DE (CENTRIC DRIVE)  
 INSTALLATION DRAWING

Serialnummer	
Materialnummer	Blatt
7462303E	1/2

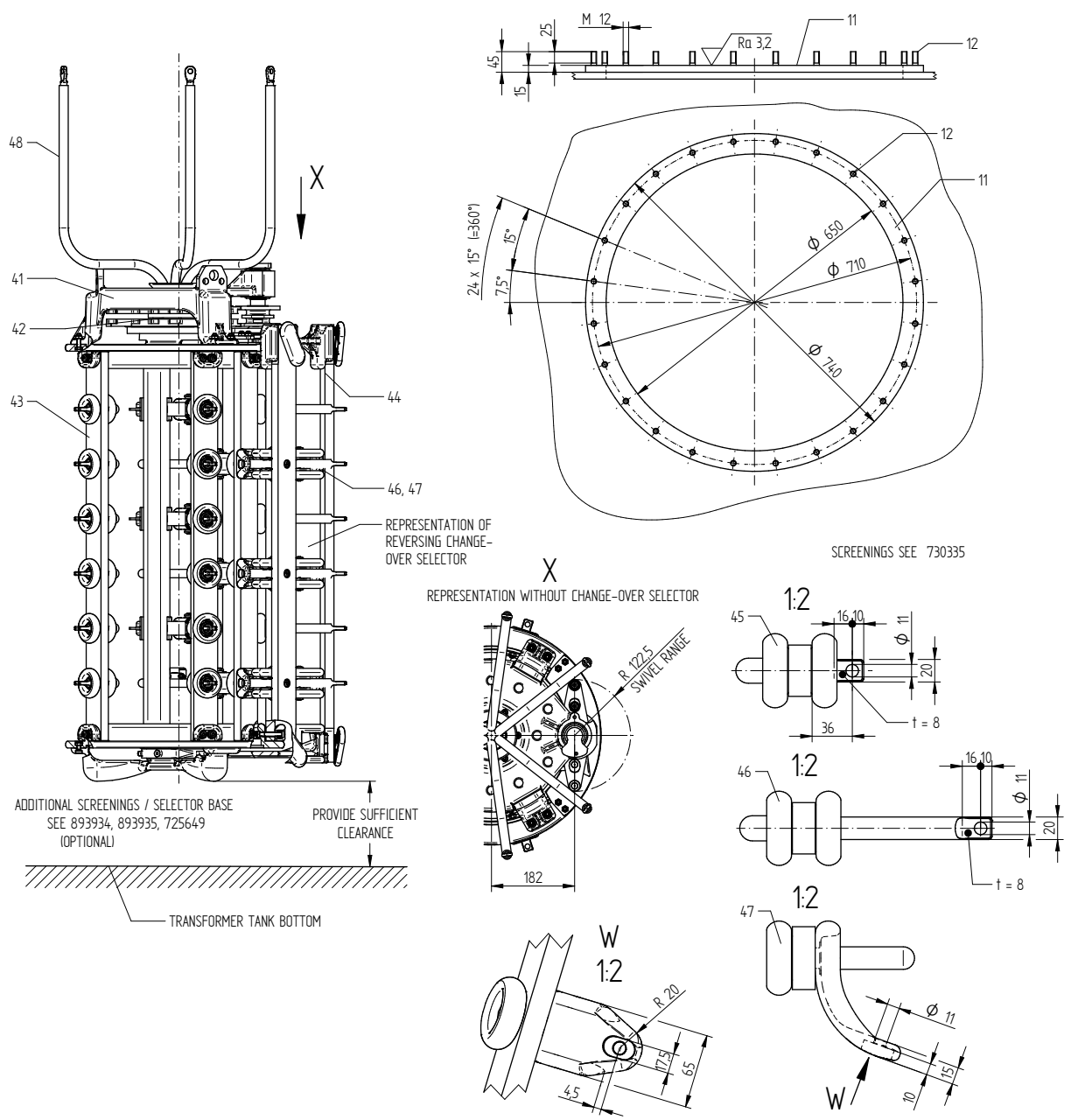

- |   |   |
|---|---|
| <p>11 MOUNTING FLANGE ON TRANSFORMER COVER<br/>                 12 FIXING BOLT M12<br/>                 13 ON-LOAD TAP-CHANGER HEAD GASKET<br/>                 14 TAP POSITION INDICATOR<br/>                 15 INSPECTION WINDOW<br/>                 16 DRIVE SHAFT FOR TAP POSITION INDICATOR<br/>                 17 THROUGH-HOLES 15mm IN DIAMETER</p> <p>21 ON-LOAD TAP-CHANGER HEAD<br/>                 22 COVER BOLT<br/>                 23 COVER GASKET<br/>                 24 ON-LOAD TAP-CHANGER HEAD COVER<br/>                 25 CENTRIC GEAR UNIT WITH DRIVE SHAFT 25a<br/>                 26 PIPE CONNECTING R FOR PROTECTIVE RELAY<br/>                 27 PIPE CONNECTING S FOR SUCTION PIPE<br/>                 28 PIPE CONNECTING Q FOR OIL RETURN PIPE (WITH OIL FILTER ONLY)<br/>                 29a AIR-VENT VALVE OF ON-LOAD TAP-CHANGER HEAD COVER<br/>                 29b BLEEDING FACILITY FOR TRANSFORMER OIL COMPARTMENT<br/>                 29c VENT SCREW FOR SUCTION PIPE</p> <p>(M) → DRIVE SIDE OF SELECTOR</p> <p>** NOT WITH MULTIPLE COARSE CHANGE-OVER SELECTOR</p> | <p>31 DIVERTER SWITCH OIL COMPARTMENT<br/>                 32 OIL COMPARTMENT BASE WITH SUPPORTING BOLT 32a<br/>                 33 SCREENING RINGS (WITH Um = 170 kV; 245 kV; 300 kV ONLY)<br/>                 34 OIL COMPARTMENT CONNECTION TERMINAL<br/>                 35 TERMINAL:<br/>                 VM III 350/500/650, VMS III 400/650: NEUTRAL CONNECTION<br/>                 VM I 351/501/651: TAKE-OFF TERMINAL<br/>                 ON-LOAD TAP-CHANGER TAKE-OFF RING (ONLY VM I 802/803/1203/1503)<br/>                 36 CONNECTING LEAD (ONLY VM I 653/803)<br/>                 37 SUCTION PIPE<br/>                 38 SCREENING RING (WITH Um = 123 kV ONLY)</p> <p>41 SELECTOR SUSPENSION<br/>                 42 SELECTOR GEAR<br/>                 43 TAP SELECTOR<br/>                 44 CHANGE-OVER SELECTOR<br/>                 45 SELECTOR CONNECTION CONTACT (SEE CORRESPONDING DIMENSION DRAWING)<br/>                 46 CHANGE-OVER SELECTOR CONNECTION CONTACT "K" OR "O" **<br/>                 47 CHANGE-OVER SELECTOR CONNECTION CONTACT "+", "—" OR "-" **<br/>                 48 SELECTOR CONNECTING LEAD</p> <p>51 DIVERTER SWITCH INSERT<br/>                 52 SUPPORTING CYLINDER<br/>                 53 BASE PLATE<br/>                 54 FIXING BOLT<br/>                 55 EYEBOLT WITH THROUGH-HOLE 25 mm IN DIAMETER<br/>                 56 TRANSITION RESISTORS</p> |
|---|---|

Datum	Name	Dokumentnummer
13.07.2018	BUTERUS	SED 2317110 001 03
Gez. bepr.	WILHELM	Änderungsnummer
16.07.2018	PRODASTSCHUK	1086956
Norm.		15

Maßangaben in mm, soweit nicht anders angegeben



ON-LOAD TAP-CHANGER VACUTAP® VM®, VMS®-C  
 M-SELECTOR SIZE B/C/D/DE (CENTRIC DRIVE)  
 INSTALLATION DRAWING

Serialnummer	
Materialnummer	Blatt
7462303E	2/2

© MASCHINENFABRIK REINHAUSEN GMBH 2018  
 THE REPRODUCTION, DISTRIBUTION AND UTILIZATION OF THIS DOCUMENT AS WELL AS THE COMMUNICATION OF ITS CONTENTS TO OTHERS WITHOUT EXPRESS AUTHORIZATION IS PROHIBITED. OFFENDERS WILL BE HELD LIABLE FOR THE PAYMENT OF DAMAGES. ALL RIGHTS RESERVED IN THE EVENT OF A PATENT, UTILITY MODEL OR DESIGN.

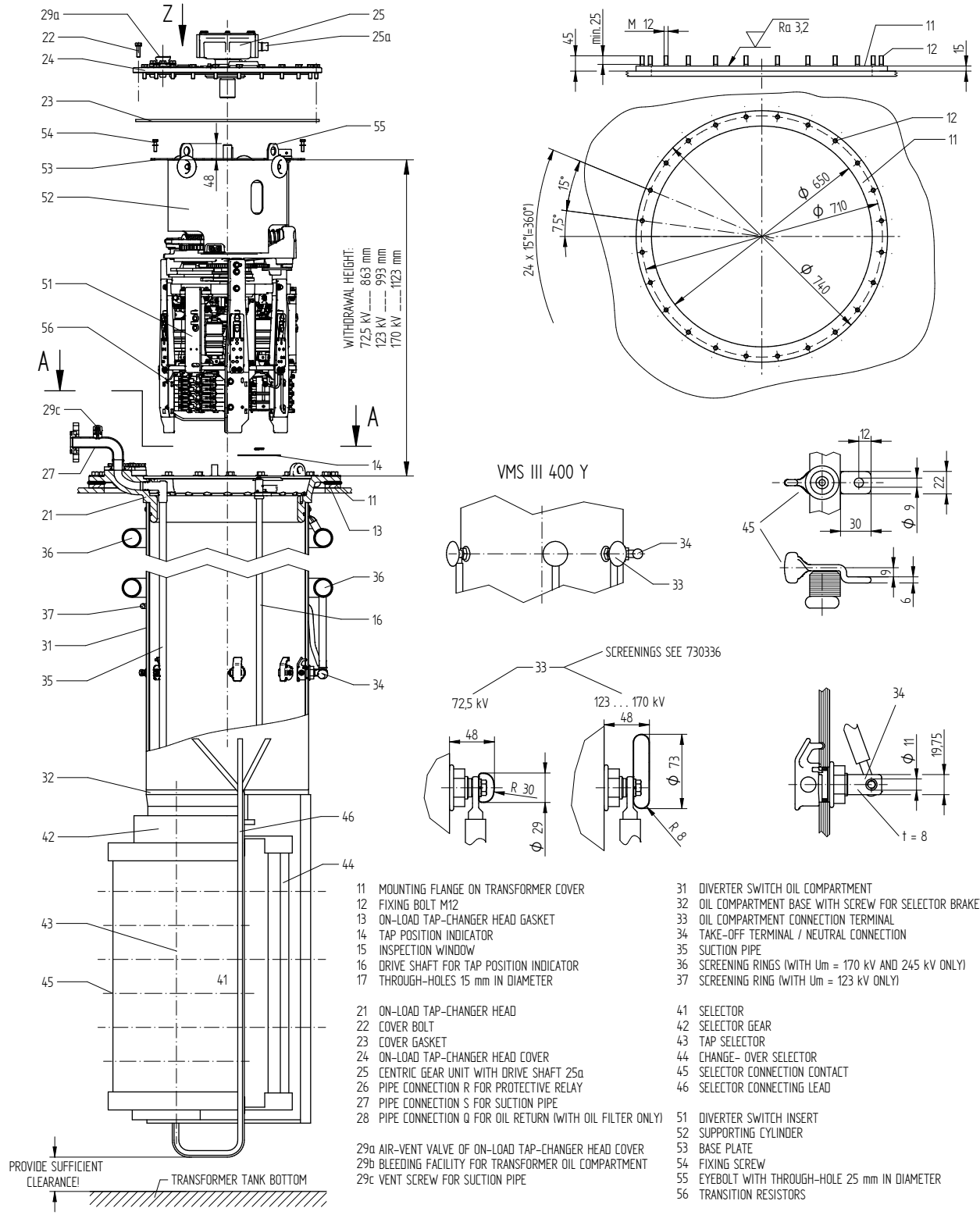

- 11 MOUNTING FLANGE ON TRANSFORMER COVER
- 12 FIXING BOLT M12
- 13 ON-LOAD TAP-CHANGER HEAD GASKET
- 14 TAP POSITION INDICATOR
- 15 INSPECTION WINDOW
- 16 DRIVE SHAFT FOR TAP POSITION INDICATOR
- 17 THROUGH-HOLES 15 mm IN DIAMETER
- 21 ON-LOAD TAP-CHANGER HEAD
- 22 COVER BOLT
- 23 COVER GASKET
- 24 ON-LOAD TAP-CHANGER HEAD COVER
- 25 CENTRIC GEAR UNIT WITH DRIVE SHAFT 25a
- 26 PIPE CONNECTION R FOR PROTECTIVE RELAY
- 27 PIPE CONNECTION S FOR SUCTION PIPE
- 28 PIPE CONNECTION Q FOR OIL RETURN (WITH OIL FILTER ONLY)
- 31 DIVERTER SWITCH OIL COMPARTMENT
- 32 OIL COMPARTMENT BASE WITH SCREW FOR SELECTOR BRACKET
- 33 OIL COMPARTMENT CONNECTION TERMINAL
- 34 TAKE-OFF TERMINAL / NEUTRAL CONNECTION
- 35 SUCTION PIPE
- 36 SCREENING RINGS (WITH Um = 170 kV AND 245 kV ONLY)
- 37 SCREENING RING (WITH Um = 123 kV ONLY)
- 41 SELECTOR
- 42 SELECTOR GEAR
- 43 TAP SELECTOR
- 44 CHANGE-OVER SELECTOR
- 45 SELECTOR CONNECTION CONTACT
- 46 SELECTOR CONNECTING LEAD
- 51 DIVERTER SWITCH INSERT
- 52 SUPPORTING CYLINDER
- 53 BASE PLATE
- 54 FIXING SCREW
- 55 EYEBOLT WITH THROUGH-HOLE 25 mm IN DIAMETER
- 56 TRANSITION RESISTORS

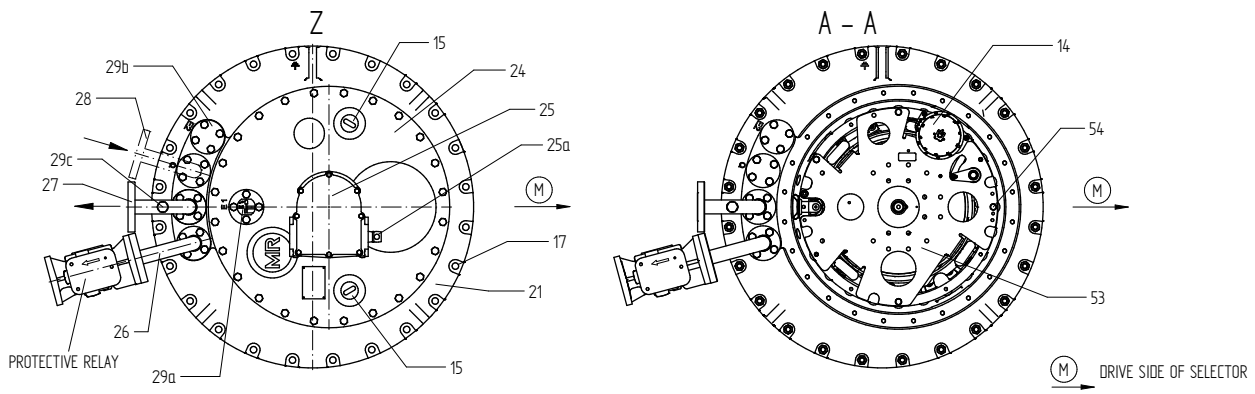

DOCUMENT NO.	NAME	DATE	SCALE
SED 6018599 001 00	BUTERUS	11.07.2018	1
CHANGE NO.	WILHELM	16.07.2018	
1086956	PRODASTSCHUK	16.07.2018	

DIMENSION IN mm EXCEPT AS NOTED



ON-LOAD TAP-CHANGER VACUTAP® VMS®  
 SELECTOR SIZE B (CENTRIC DRIVE)  
 INSTALLATION DRAWING

SERIAL NUMBER	
MATERIAL NUMBER	SHEET
101170220E	1/1

© MASCHINENFABRIK REINHAUSEN GMBH 2017  
 THE REPRODUCTION, DISTRIBUTION AND UTILIZATION OF THIS DOCUMENT AS WELL AS THE COMMUNICATION OF ITS CONTENTS TO OTHERS WITHOUT EXPRESS AUTHORIZATION IS PROHIBITED. OFFENDERS WILL BE HELD LIABLE FOR THE PAYMENT OF DAMAGES. ALL RIGHTS RESERVED IN THE EVENT OF A PATENT, UTILITY MODEL OR DESIGN.

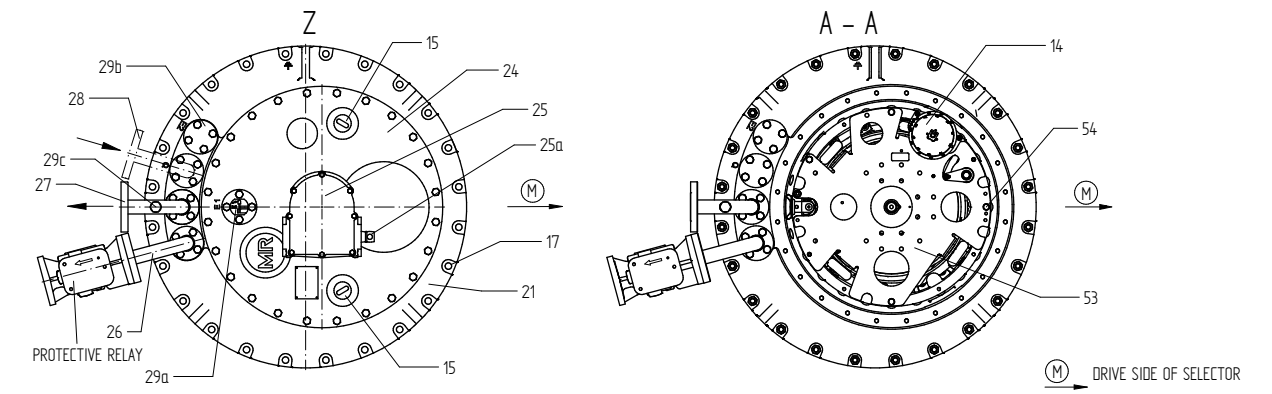
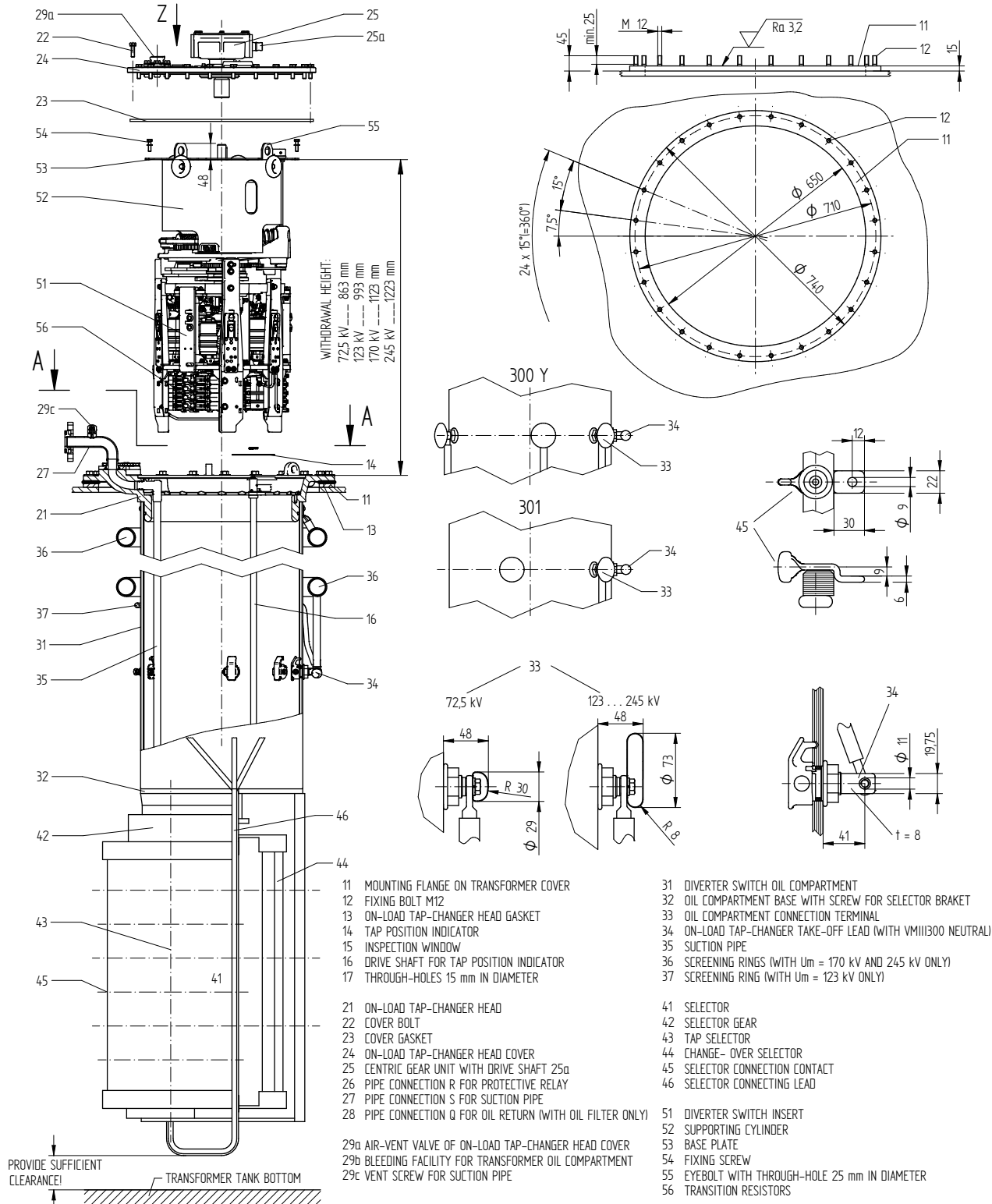

- |  |  |
|--|--|
| <ul style="list-style-type: none"> <li>11 MOUNTING FLANGE ON TRANSFORMER COVER</li> <li>12 FIXING BOLT M12</li> <li>13 ON-LOAD TAP-CHANGER HEAD GASKET</li> <li>14 TAP POSITION INDICATOR</li> <li>15 INSPECTION WINDOW</li> <li>16 DRIVE SHAFT FOR TAP POSITION INDICATOR</li> <li>17 THROUGH-HOLES 15 mm IN DIAMETER</li> <li>21 ON-LOAD TAP-CHANGER HEAD</li> <li>22 COVER BOLT</li> <li>23 COVER GASKET</li> <li>24 ON-LOAD TAP-CHANGER HEAD COVER</li> <li>25 CENTRIC GEAR UNIT WITH DRIVE SHAFT 25a</li> <li>26 PIPE CONNECTION R FOR PROTECTIVE RELAY</li> <li>27 PIPE CONNECTION S FOR SUCTION PIPE</li> <li>28 PIPE CONNECTION Q FOR OIL RETURN (WITH OIL FILTER ONLY)</li> <li>29a AIR-VENT VALVE OF ON-LOAD TAP-CHANGER HEAD COVER</li> <li>29b BLEEDING FACILITY FOR TRANSFORMER OIL COMPARTMENT</li> <li>29c VENT SCREW FOR SUCTION PIPE</li> </ul> | <ul style="list-style-type: none"> <li>31 DIVERTER SWITCH OIL COMPARTMENT</li> <li>32 OIL COMPARTMENT BASE WITH SCREW FOR SELECTOR BRACKET</li> <li>33 OIL COMPARTMENT CONNECTION TERMINAL</li> <li>34 ON-LOAD TAP-CHANGER TAKE-OFF LEAD (WITH VMIII300 NEUTRAL)</li> <li>35 SUCTION PIPE</li> <li>36 SCREENING RINGS (WITH Um = 170 kV AND 245 kV ONLY)</li> <li>37 SCREENING RING (WITH Um = 123 kV ONLY)</li> <li>41 SELECTOR</li> <li>42 SELECTOR GEAR</li> <li>43 TAP SELECTOR</li> <li>44 CHANGE-OVER SELECTOR</li> <li>45 SELECTOR CONNECTION CONTACT</li> <li>46 SELECTOR CONNECTING LEAD</li> <li>51 DIVERTER SWITCH INSERT</li> <li>52 SUPPORTING CYLINDER</li> <li>53 BASE PLATE</li> <li>54 FIXING SCREW</li> <li>55 EYEBOLT WITH THROUGH-HOLE 25 mm IN DIAMETER</li> <li>56 TRANSITION RESISTORS</li> </ul> |
|--|--|

DOCUMENT NO.	SED 2416809 001 02	
NAME	RAEDLINGER	HAUER
DATE	10.02.2017	29.03.2017
DFTR.	10.02.2017	29.03.2017
CHKD.	10.02.2017	29.03.2017
STAND.	10.02.2017	29.03.2017
SCALE	1	
CHANGE NO.	1079192	
PRODASTSCHUK	1079192	

DIMENSION IN mm EXCEPT AS NOTED



**ON-LOAD TAP-CHANGER VACUTAP® VM 300**  
**SELECTOR SIZE B (CENTRIC DRIVE)**  
**INSTALLATION DRAWING**

SERIAL NUMBER	
MATERIAL NUMBER	SHEET
7651922E	1/1

© MASCHINENFABRIK REINHAUSEN GMBH 2015  
 THE REPRODUCTION, DISTRIBUTION AND UTILIZATION OF THIS DOCUMENT AS WELL AS THE COMMUNICATION OF ITS CONTENTS TO OTHERS WITHOUT EXPRESS AUTHORIZATION IS PROHIBITED. OFFENDERS WILL BE HELD LIABLE FOR THE PAYMENT OF DAMAGES. ALL RIGHTS RESERVED IN THE EVENT OF THE GRANT OF A PATENT, UTILITY MODEL OR DESIGN.

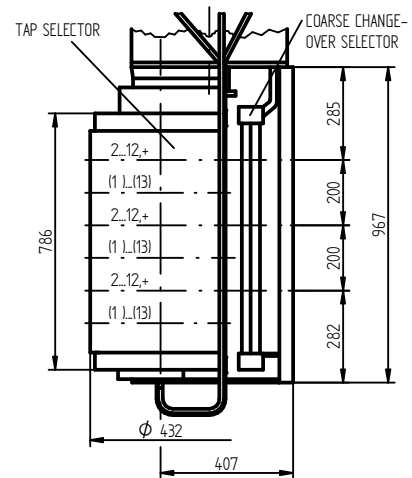
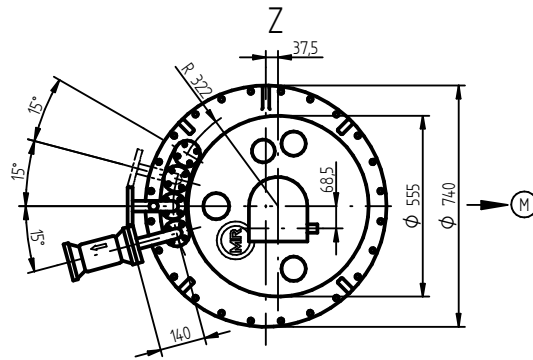
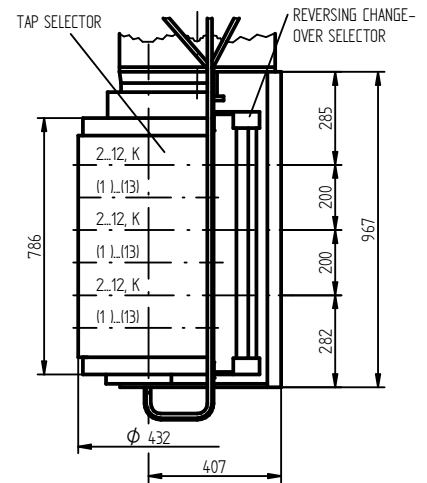
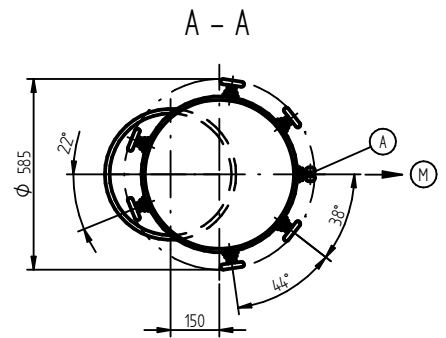
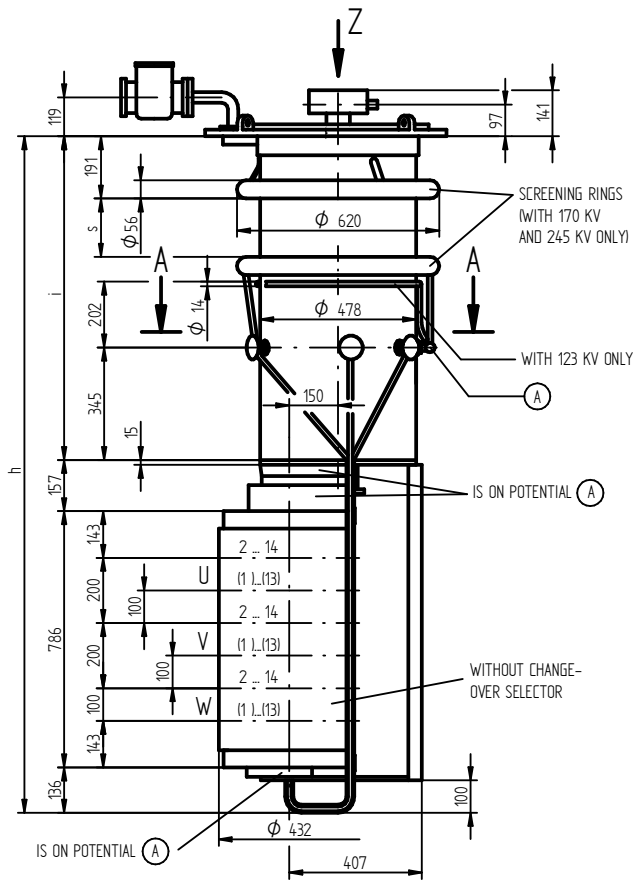

DATE	NAME	DOCUMENT NO.
18.11.2015	RAEDLINGER	SED 2532402 001 02
CHKD.	TKBIRKMAN	SCALE
01.12.2015	PRODASTSCHUK	1:8
STAND		CHANGE NO. 1069171

FOR INHERENT DRAWINGS REFER TO 898026

- (A) ON-LOAD TAP-CHANGER TAKE-OFF LEAD (NEUTRAL)
- (M) DRIVE SIDE OF SELECTOR

FOR BINDING DESIGNATIONS OF TERMINALS AND PHASES REFER TO THE CONNECTION DIAGRAM OF THE ON-LOAD TAP-CHANGER.

SELECTOR SIZE	B			
$U_M$ [kV]	72,5	123	170	245
DIMENSIONS [MM]	h	1942	2072	2202
	i	863	993	1123
	s	-		267
OIL VOLUME [DM <sup>3</sup> ]	130	150	170	190
DISPLACEMENT [DM <sup>3</sup> ]	190	220	240	260
MAX. WEIGHT [KG]	280	285	290	295

DIMENSION IN mm EXCEPT AS NOTED



ON-LOAD TAP-CHANGER VACUTAP® VM®  
 VM III 300 Y - B- 0/W/G  
 DIMENSION DRAWING

SERIAL NUMBER

MATERIAL NUMBER 7686982E SHEET 1/1

© MASCHINENFABRIK REINHAUSEN GMBH 2016  
 THE REPRODUCTION, DISTRIBUTION AND UTILIZATION OF THIS DOCUMENT AS WELL AS THE COMMUNICATION OF ITS CONTENTS TO OTHERS WITHOUT EXPRESS AUTHORIZATION IS PROHIBITED. OFFENDERS WILL BE HELD LIABLE FOR THE PAYMENT OF DAMAGES. ALL RIGHTS RESERVED IN THE EVENT OF THE GRANT OF A PATENT, UTILITY MODEL OR DESIGN.

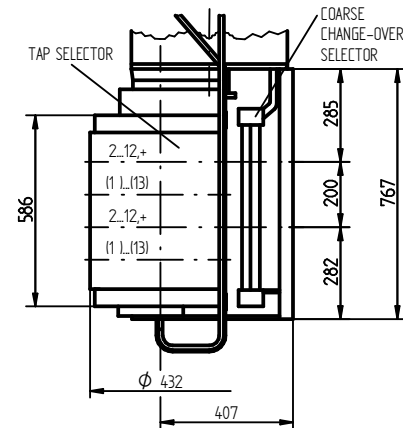
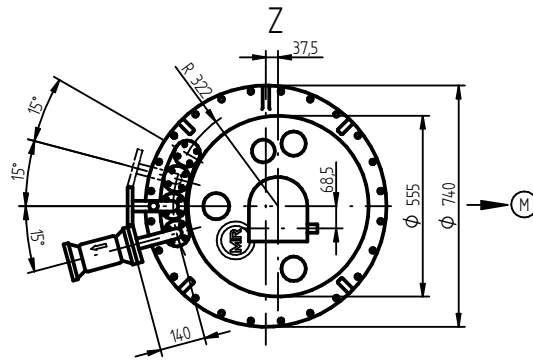
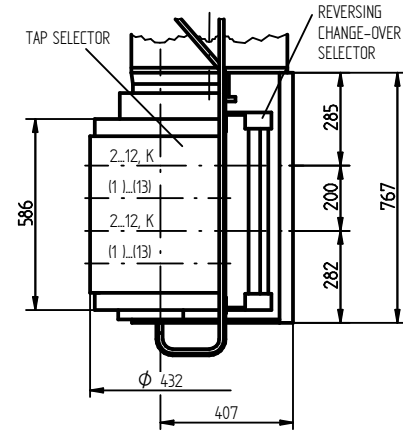
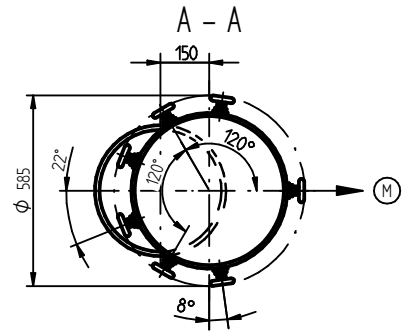
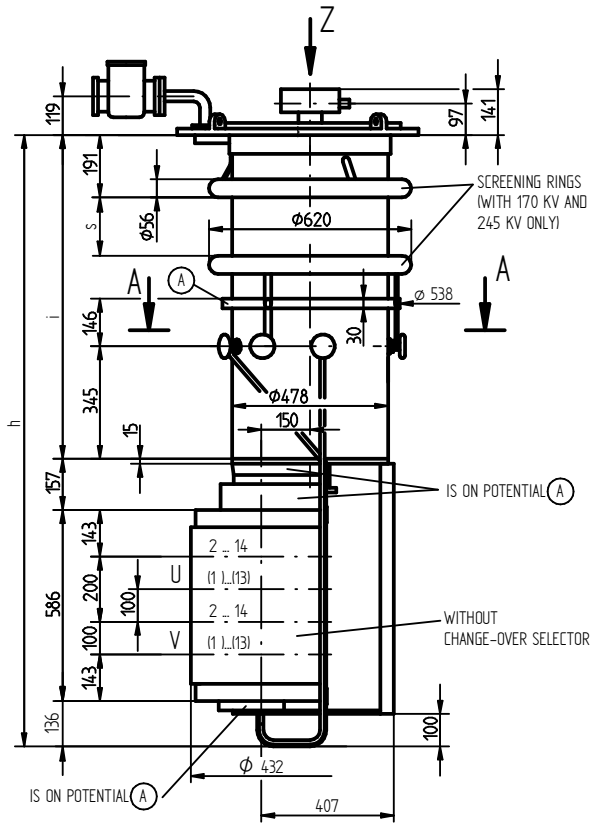

DATE	NAME	DOCUMENT NO.
01.04.2016	RAEDLINGER	SED 2742981 001 02
CHKD. 11.04.2016	MENZELS	SCALE
STAND 11.04.2016	PRODASTSCHUK	18
		CHANGE NO. 1073378

FOR INHERENT DRAWINGS REFER TO 898026

- (A) ON-LOAD TAP-CHANGER TAKE-OFF TERMINAL
- (M) DRIVE SIDE OF SELECTOR

FOR BINDING DESIGNATIONS OF TERMINALS AND PHASES REFER TO THE CONNECTION DIAGRAM OF THE ON-LOAD TAP-CHANGER.

SELECTOR SIZE	B			
$U_M$ [KV]	72,5	123	170	245
DIMENSIONS [MM]	h	1742	1872	2002
	i	863	993	1123
	s	-		267
OIL VOLUME [DM <sup>3</sup> ]	130	150	170	190
DISPLACEMENT [DM <sup>3</sup> ]	180	210	230	250
MAX. WEIGHT [KG]	260	265	270	275

DIMENSION IN mm EXCEPT AS NOTED



ON-LOAD TAP-CHANGER VACUTAP® VM®  
 VM II 302 - B - 0/W/G  
 DIMENSION DRAWING

SERIAL NUMBER

MATERIAL NUMBER 7692252E SHEET 1/1

© MASCHINENFABRIK REINHAUSEN GMBH 2015  
 THE REPRODUCTION, DISTRIBUTION AND UTILIZATION OF THIS DOCUMENT AS WELL AS THE COMMUNICATION OF ITS CONTENTS TO OTHERS WITHOUT EXPRESS AUTHORIZATION IS PROHIBITED. OFFENDERS WILL BE HELD LIABLE FOR THE PAYMENT OF DAMAGES. ALL RIGHTS RESERVED IN THE EVENT OF THE GRANT OF A PATENT, UTILITY MODEL OR DESIGN.

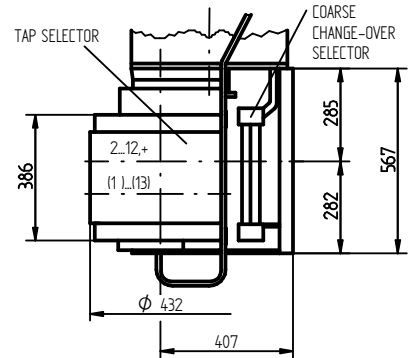
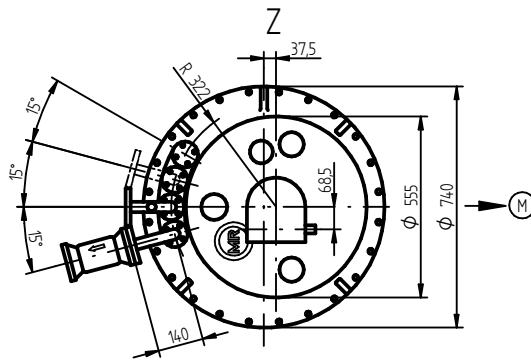
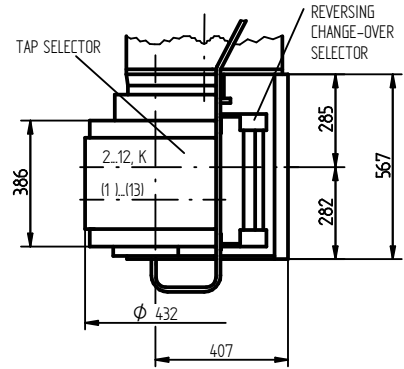
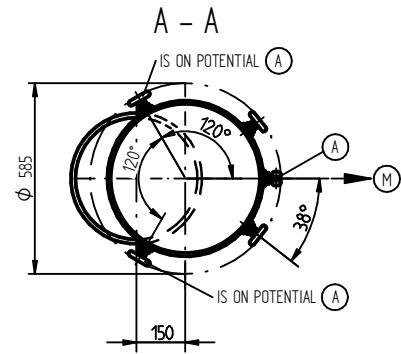
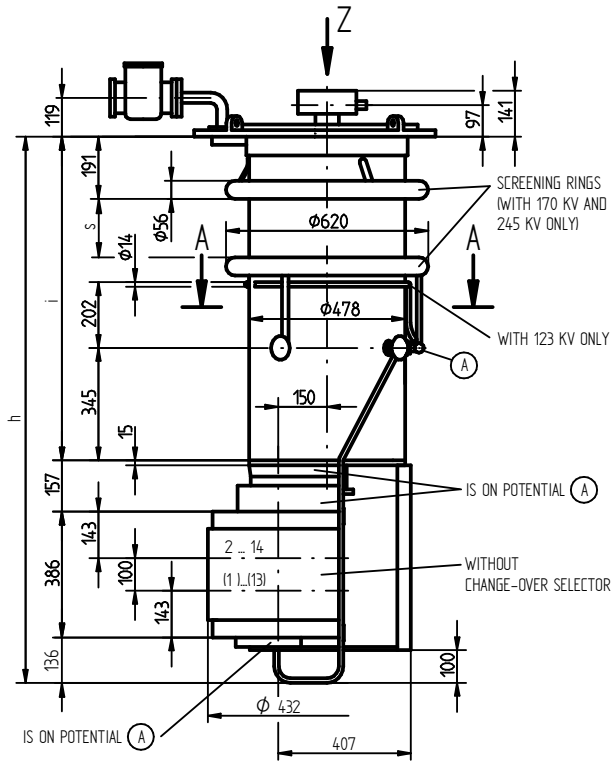

FOR INHERENT DRAWINGS REFER TO 898026

- (A) ON-LOAD TAP-CHANGER TAKE-OFF LEAD
- (M) DRIVE SIDE OF SELECTOR

FOR BINDING DESIGNATIONS OF TERMINALS AND PHASES REFER TO THE CONNECTION DIAGRAM OF THE ON-LOAD TAP-CHANGER.

SELECTOR SIZE	B			
$U_M$ [KV]	72,5	123	170	245
DIMENSIONS [MM]	h	1542	1672	1802
	i	863	993	1123
	s	—		267
OIL VOLUME [DM <sup>3</sup> ]	130	150	170	190
DISPLACEMENT [DM <sup>3</sup> ]	160	190	210	230
MAX. WEIGHT [KG]	240	245	250	255

DATE	NAME	DOCUMENT NO.
18.11.2015	RAEDLINGER	SED 2743003 001 01
CHKD.	TKBIRKMAN	SCALE
01.12.2015	PRODASTSCHUK	1:8
STAND	01.12.2015	1069171

DIMENSION IN mm EXCEPT AS NOTED



ON-LOAD TAP-CHANGER VACUTAP® VM®  
 VM I 301 - B - 0/W/G  
 DIMENSION DRAWING

SERIAL NUMBER

MATERIAL NUMBER 7692261E SHEET 1/1

© MASCHINENFABRIK REINHAUSEN GMBH 2015  
 THE REPRODUCTION, DISTRIBUTION AND UTILIZATION OF THIS DOCUMENT AS WELL AS THE COMMUNICATION OF ITS CONTENTS TO OTHERS WITHOUT EXPRESS AUTHORIZATION IS PROHIBITED. OFFENDERS WILL BE HELD LIABLE FOR THE PAYMENT OF DAMAGES. ALL RIGHTS RESERVED IN THE EVENT OF THE GRANT OF A PATENT, UTILITY MODEL OR DESIGN.

### VM I 301 - 0 / W / G

SELECTOR SIDE		B			
Um [kV]		72.5	123	170	245
DIMENSIONS [MM]	h	1542	1672	1802	1902
	i	863	993	1123	1223
	s	-	-	267	367
OIL VOLUME [DM <sup>3</sup> ]		130	150	170	190
DISPLACEMENT [DM <sup>3</sup> ]		160	190	210	230
MAX. WEIGHT [KG]		240	245	250	255

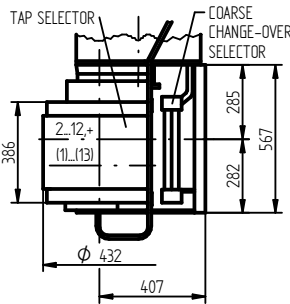
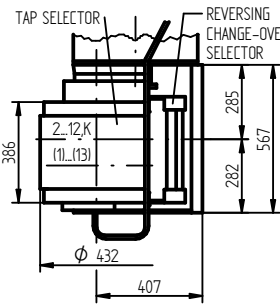
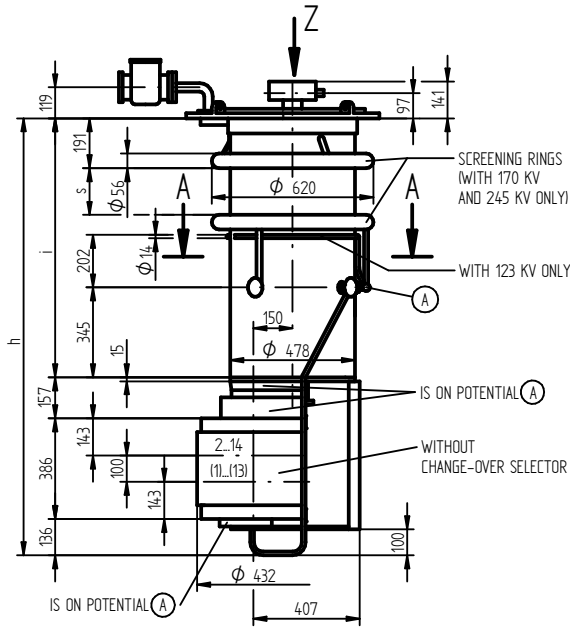

### VM II 302 - 0 / W / G

SELECTOR SIDE		B			
Um [kV]		72.5	123	170	245
DIMENSIONS [MM]	h	1742	1872	2002	2102
	i	863	993	1123	1223
	s	-	-	267	367
OIL VOLUME [DM <sup>3</sup> ]		130	150	170	190
DISPLACEMENT [DM <sup>3</sup> ]		180	210	230	250
MAX. WEIGHT [KG]		260	265	270	275

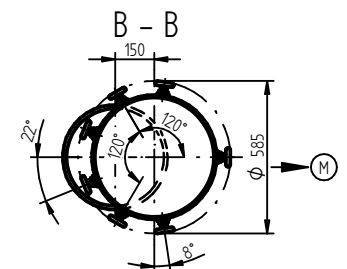
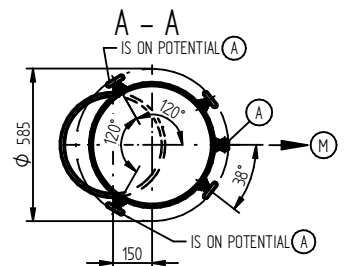
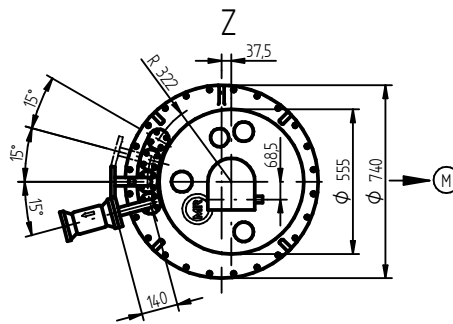
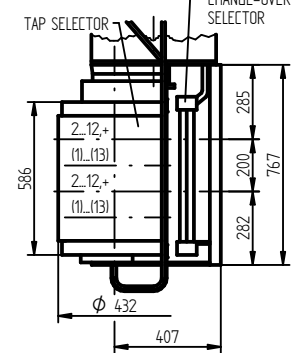
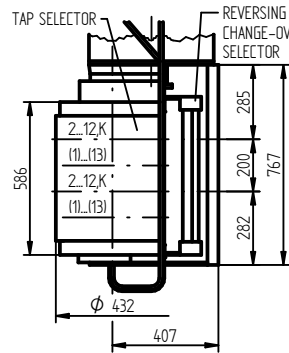
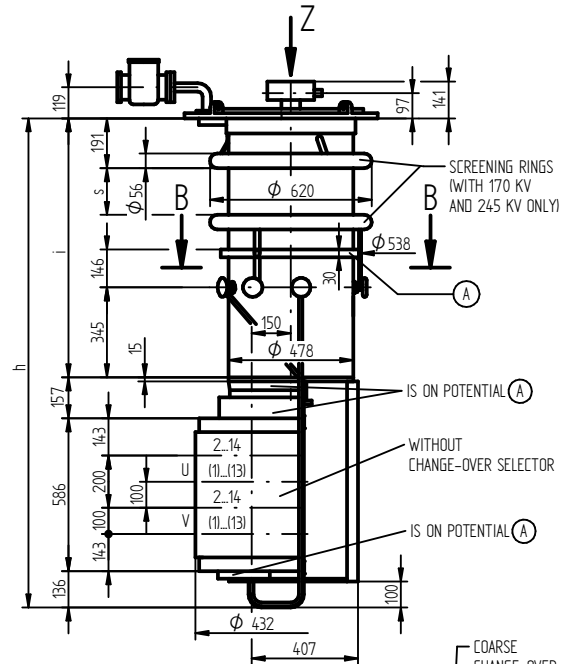

FOR INHERENT DRAWINGS REFER TO 898026

- (A) ON-LOAD TAP-CHANGER TAKE-OFF LEAD
- (M) DRIVE SIDE OF SELECTOR

FOR BINDING DESIGNATIONS OF TERMINALS AND PHASES REFER TO THE CONNECTION DIAGRAM OF THE ON-LOAD TAP-CHANGER.

DATE	NAME	DOCUMENT NO.
18.11.2015	RAEDLINGER	SED 2559763 001 02
01.12.2015	TKBIRKMAN	CHANGE NO.
01.12.2015	PRODASTSCHUK	1069171
		SCALE 1:10

DIMENSION IN mm EXCEPT AS NOTED



ON-LOAD TAP-CHANGER VACUTAP® VM®  
 VM III 300 K - B - 0/W/G  
 DIMENSION DRAWING

SERIAL NUMBER

MATERIAL NUMBER 7688512E SHEET 1/1



## 4.3 Головка устройства РПН

© MASCHINENFABRIK REINHAUSEN GMBH 2018  
 THE REPRODUCTION, DISTRIBUTION AND UTILIZATION OF THIS DOCUMENT AS WELL AS THE COMMUNICATION OF ITS CONTENTS TO OTHERS WITHOUT EXPRESS AUTHORIZATION IS PROHIBITED. OFFENDERS WILL BE HELD LIABLE FOR THE PAYMENT OF DAMAGES. ALL RIGHTS RESERVED IN THE EVENT OF THE GRANT OF A PATENT, UTILITY MODEL OR DESIGN.

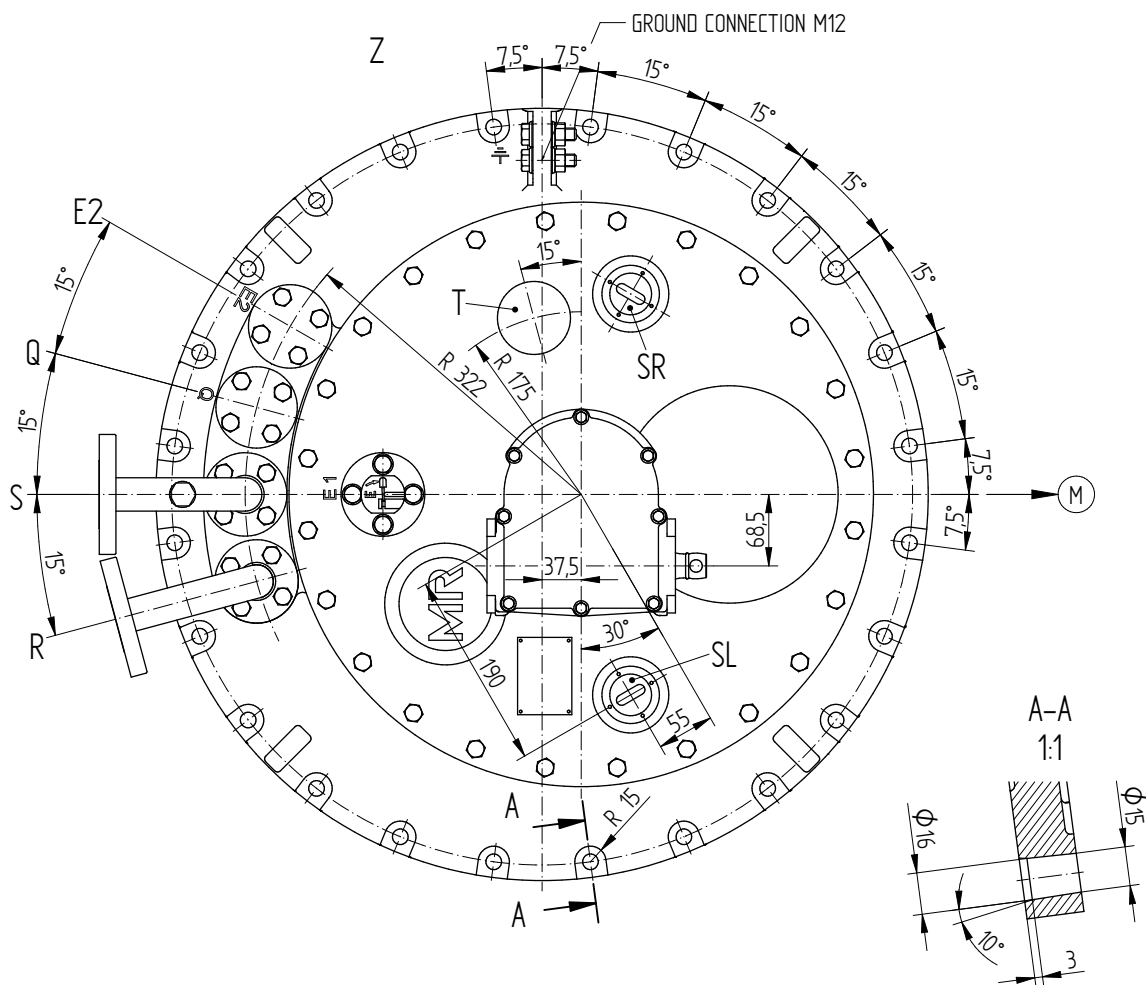
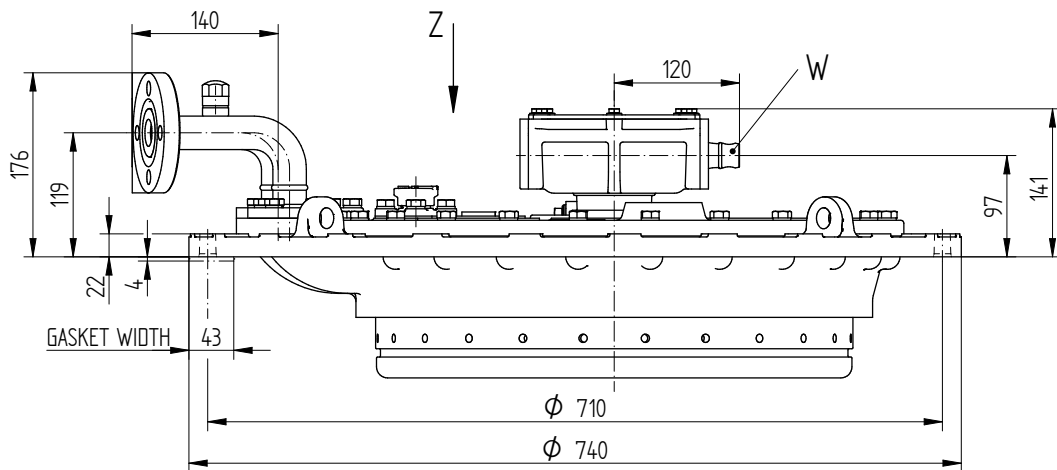

E1 = BLEEDING FACILITY FOR ON-LOAD TAP-CHANGER HEAD

E2 = BLEEDING FACILITY FOR SPACE UNDER THE HEAD OUTSIDE

THE TAP-CHANGER OIL COMPARTMENT (SAME PIPE CONNECTION AS R, S, Q OR BLEEDER SCREW CAN BE USED)

Q = CONNECTION FOR OIL RETURN PIPE OR TAP-CHANGE SUPERVISORY CONTROL

S = CONNECTION FOR SUCTION PIPE

R = CONNECTION FOR PROTECTIVE RELAY (EXCHANGEABLE WITH CONNECTION Q)

T = THERMOMETER BAG / TEMPERATURE SENSOR (OPTIONALLY)

SR = INSPECTION WINDOW, RIGHT

SL = INSPECTION WINDOW, LEFT

W = DRIVE SHAFT

(M) DRIVE SIDE OF SELECTOR

CONNECTIONS SWIVELING  
 DIMENSIONS AND SELECTION 899496: / 899497:

DATE	NAME	DOCUMENT NO.
DFTR. 11.07.2018	BUTERUS	SED 1661272 001 04
CHKD. 16.07.2018	WILHELM	SCALE 1:2,5
STAND. 16.07.2018	PRODASTSCHUK	CHANGE NO. 1086956

DIMENSION  
 IN mm  
 EXCEPT AS  
 NOTED



ON-LOAD TAP-CHANGER  
 OILTAP® M, MS, R, RM AND VACUTAP® VR®, VM®, VMS®  
 ON-LOAD TAP-CHANGER HEAD, CENTRIC DRIVE

SERIAL NUMBER

MATERIAL NUMBER  
 893899FE

SHEET  
 1/1

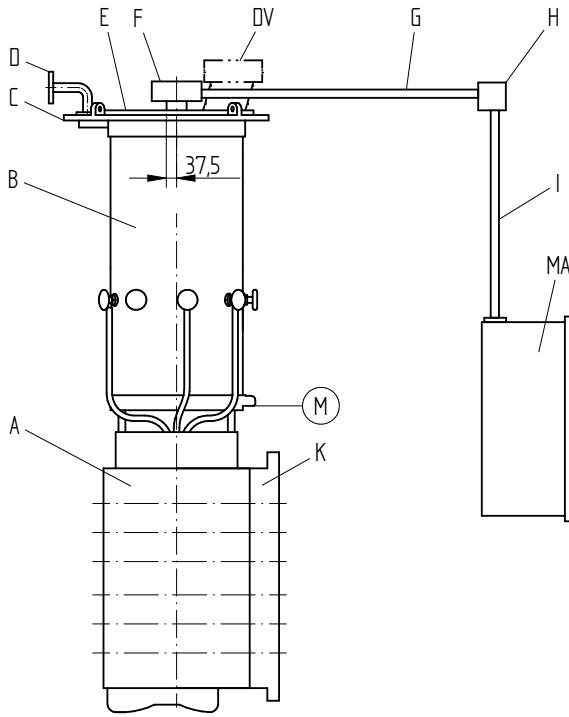

- A = selector
  - K = change-over selector
  - B = diverter switch oil compartment
  - C = on-load tap-changer head
  - D = pipe connections (R, S, Q, E2)
  - DV = pressure relief device
  - E = on-load tap-changer head cover
  - F = upper gear unit
  - G = drive shaft, horizontal
  - H = bevel gear
  - I = drive shaft, vertical
  - MA = motor-drive unit
  - Ⓜ = drive side of selector
  - SR = inspection window on the right
  - SL = inspection window on the left
  - T = temperature sensor
- } represented version type M

### Position of drive shaft of gear unit

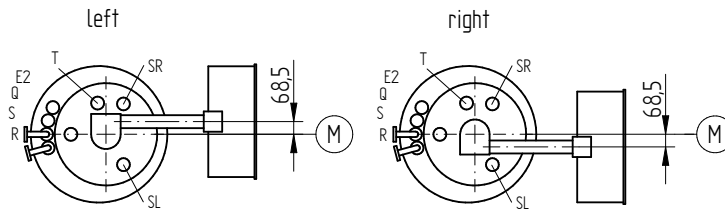

### Head variants

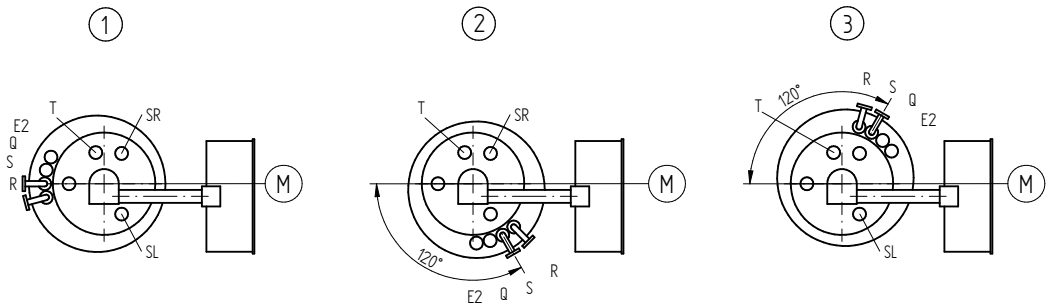

### Swivel ranges

A considerable number of variants of the on-load tap-changer head are available for adapting the horizontal part of the drive shaft to the transformer tank.

The mounting position of the selector A and diverter switch oil compartment B is determined by the drive side of selector (Ⓜ).

The on-load tap-changer head C together with its pipe connections D may be turned through 120 degrees clockwise or anti-clockwise. This results in the variants 1, 2 and 3.

The upper gear unit F can be turned continuously on its own axis. Table 720027: Lists the limitation of the swivel range for the particular head variant. The angle specifications refer to the center of rotation of the gear unit. Pay particular attention to the offset of the drive shaft.

DATE	11.07.2018	DOCUMENT NO.	SED 1063796 001 05
DATE	16.07.2018	NAME	BUTERUS
DATE	16.07.2018	NAME	WILHELM
DATE	16.07.2018	NAME	PRODASTSCHUK
CHG. NO.	1086956	SCALE	1

DIMENSION  
IN mm  
EXCEPT AS  
NOTED



**ON-LOAD TAP-CHANGER**  
**OILTAP® MS, M, RM, R AND VACUTAP® VR®, VM®, VMS®**  
**VARIANTS OF THE ON-LOAD TAP-CHANGER HEAD**

SERIAL NUMBER

MATERIAL NUMBER  
7200264E

SHEET  
1/1

© MASCHINENFABRIK REINHAUSEN GMBH 2018  
 THE REPRODUCTION, DISTRIBUTION AND UTILIZATION OF THIS DOCUMENT AS WELL AS THE COMMUNICATION OF ITS CONTENTS TO OTHERS WITHOUT EXPRESS AUTHORIZATION IS PROHIBITED. OFFENDERS WILL BE HELD LIABLE FOR THE PAYMENT OF DAMAGES. ALL RIGHTS RESERVED IN THE EVENT OF THE GRANT OF A PATENT, UTILITY MODEL OR DESIGN.

DATE	NAME	DOCUMENT NO.
11.07.2018	BUTERUS	SED 1664686 001 04
16.07.2018	WILHELM	CHANGE NO. SCALE
16.07.2018	PRODASTSCHUK	1086956 1

SKETCH	HEAD VERSION COMPONENTS USED	LIMITATION OF THE SWIVEL RANGE
	DRIVE SHAFT RIGHT HEAD VERSION 1	
	PIPE CONNECTION R	-168°  -140°
	PIPE CONNECTION S	-155° 177°
	PIPE CONNECTION Q	-171° 162°
	PIPE CONNECTION E2	147°  174°
	PRESSURE RELIEF DEVICE DV	-150° -35°
	TEMPERATURE SENSOR T	96°  175°
INSPECTION WINDOW SL / SR	-64°  SL -8° 56°  SR 112°	
	DRIVE SHAFT RIGHT HEAD VERSION 2	
	PIPE CONNECTION R	-48°  -21°
	PIPE CONNECTION S	-63°  -36°
	PIPE CONNECTION Q	-78°  -51°
	PIPE CONNECTION E2	-93°  -66°
	PRESSURE RELIEF DEVICE DV	-150° -35°
	TEMPERATURE SENSOR T	96°  175°
INSPECTION WINDOW SR	56°  SR 112°	
	DRIVE SHAFT RIGHT HEAD VERSION 3	
	PIPE CONNECTION R	72°  99°
	PIPE CONNECTION S	57°  84°
	PIPE CONNECTION Q	42°  69°
	PIPE CONNECTION E2	27°  54°
	PRESSURE RELIEF DEVICE DV	-150° -35°
	TEMPERATURE SENSOR T	96°  175°
INSPECTION WINDOW SL	-64°  SL -8°	
	DRIVE SHAFT LEFT HEAD VERSION 1	
	PIPE CONNECTION R	-162° 171°
	PIPE CONNECTION S	-177° 156°
	PIPE CONNECTION Q	141°  168°
	PIPE CONNECTION E2	126°  153°
	PRESSURE RELIEF DEVICE DV	35° 150°
	TEMPERATURE SENSOR T	34°  114°
INSPECTION WINDOW SL / SR	-112°  SL -56° 8°  SR 64°	
	DRIVE SHAFT LEFT HEAD VERSION 2	
	PIPE CONNECTION R	-69°  -42°
	PIPE CONNECTION S	-84°  -57°
	PIPE CONNECTION Q	-99°  -72°
	PIPE CONNECTION E2	-114°  -87°
	PRESSURE RELIEF DEVICE DV	35° 150°
	TEMPERATURE SENSOR T	34°  114°
INSPECTION WINDOW SR	8°  SR 64°	
	DRIVE SHAFT LEFT HEAD VERSION 3	
	PIPE CONNECTION R	50°  78°
	PIPE CONNECTION S	35°  62°
	PIPE CONNECTION Q	21°  48°
	PIPE CONNECTION E2	6°  33°
	PRESSURE RELIEF DEVICE DV	35° 150°
	TEMPERATURE SENSOR T	34°  114°
INSPECTION WINDOW SL	-112°  SL -56°	

- LIMITATION OF THE SWIVEL RANGE THROUGH PIPE CONNECTIONS R AND S
- LIMITATION OF THE SWIVEL RANGE THROUGH OPTIONAL EXISTING PIPE CONNECTIONS Q, E2 AND PRESSURE RELIEF DEVICE DV
- SWIVEL RANGE POSSIBLE, BUT THE TEMPERATURE SENSOR T AND THE INSPECTION WINDOW SL / SR ARE NOT VISIBLE

DIMENSION  
IN mm  
EXCEPT AS  
NOTED



ON-LOAD TAP-CHANGER  
OILTAP® MS, M, RM, R AND VACUTAP® VR®, VM®, VMS®  
SWIVEL RANGE OF THE GEAR UNIT

SERIAL NUMBER

MATERIAL NUMBER	SHEET
7200276E	1/1

© MASCHINENFABRIK REINHOLDEN GMBH 2018  
 THE REPRODUCTION, DISTRIBUTION AND UTILIZATION OF THIS DOCUMENT AS WELL AS THE COMMUNICATION OF ITS CONTENTS TO OTHERS WITHOUT EXPRESS AUTHORIZATION IS PROHIBITED. OFFENDERS WILL BE HELD LIABLE FOR THE PAYMENT OF DAMAGES. ALL RIGHTS RESERVED IN THE EVENT OF A PATENT, UTILITY MODEL OR DESIGN.

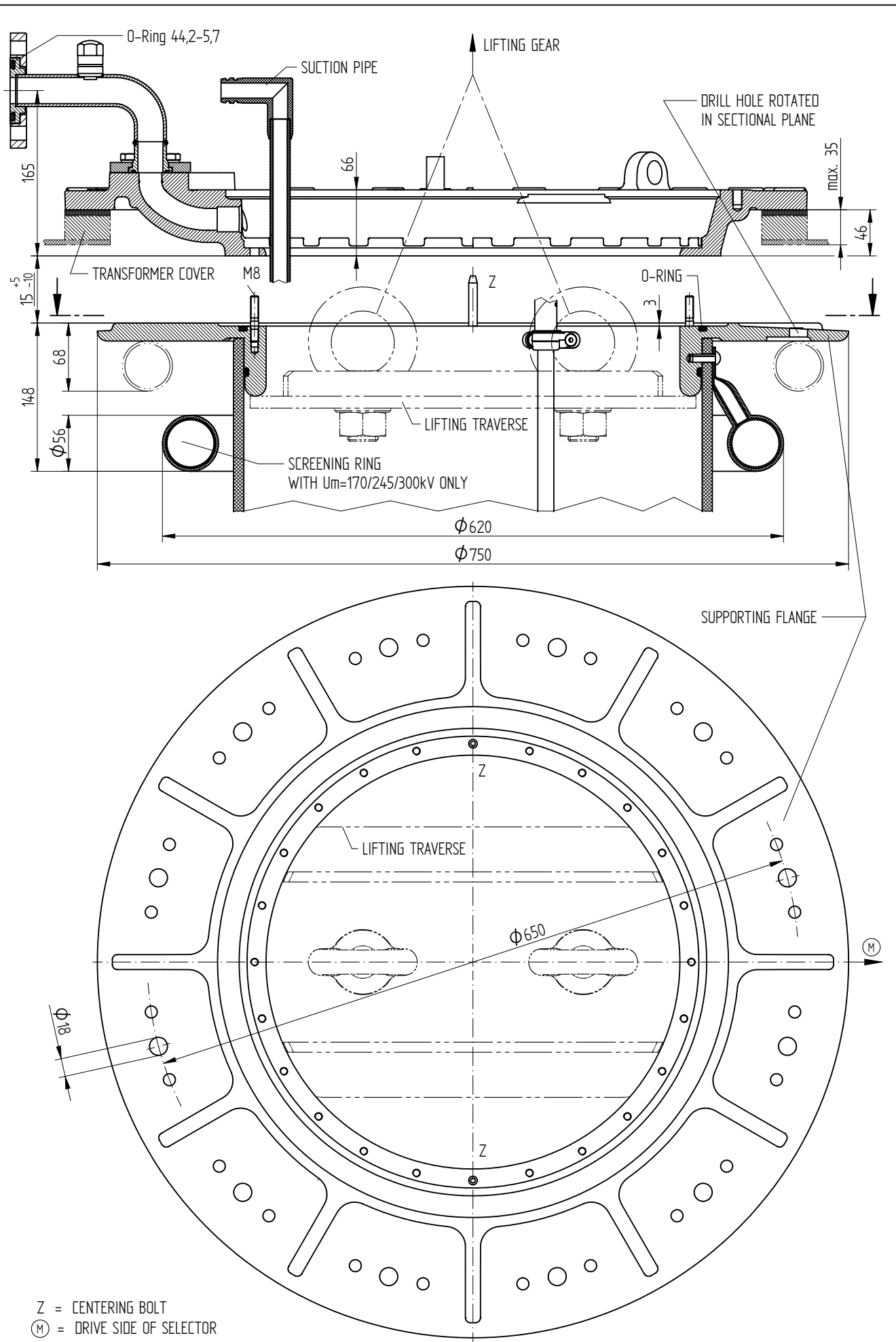

DATE	NAME	DOCUMENT NO.
13.07.2018	BUTERUS	SED 1507378 000 04
16.07.2018	WILHELM	CHANGE NO.
16.07.2018	PRODASTSCHUK	1086956
		SCALE
		1:2,5

DIMENSION  
 IN mm  
 EXCEPT AS  
 NOTED



ON-LOAD TAP-CHANGER  
 OILTAP® M, R, RM, MS AND VACUTAP® VM®, VMS®  
 SPECIAL DESIGN BELL-TYPE TANK INSTALLATION FOR Um UP TO 300 kV

SERIAL NUMBER	
MATERIAL NUMBER	SHEET
896762CE	1/1

© MASCHINENFABRIK REINHAUSEN GMBH 2018  
 THE REPRODUCTION, DISTRIBUTION AND UTILIZATION OF THIS DOCUMENT AS WELL AS THE COMMUNICATION OF ITS CONTENTS TO OTHERS WITHOUT EXPRESS AUTHORIZATION IS PROHIBITED. OFFENDERS WILL BE HELD LIABLE FOR THE PAYMENT OF DAMAGES. ALL RIGHTS RESERVED IN THE EVENT OF THE GRANT OF A PATENT, UTILITY MODEL OR DESIGN.

DATE	NAME	DOCUMENT NO.
13.07.2018	BUTERUS	SED 1706827 001 05
16.07.2018	WILHELM	CHANGE NO.
16.07.2018	PRODASTSCHUK	1086956
CHKO.	SCALE	1

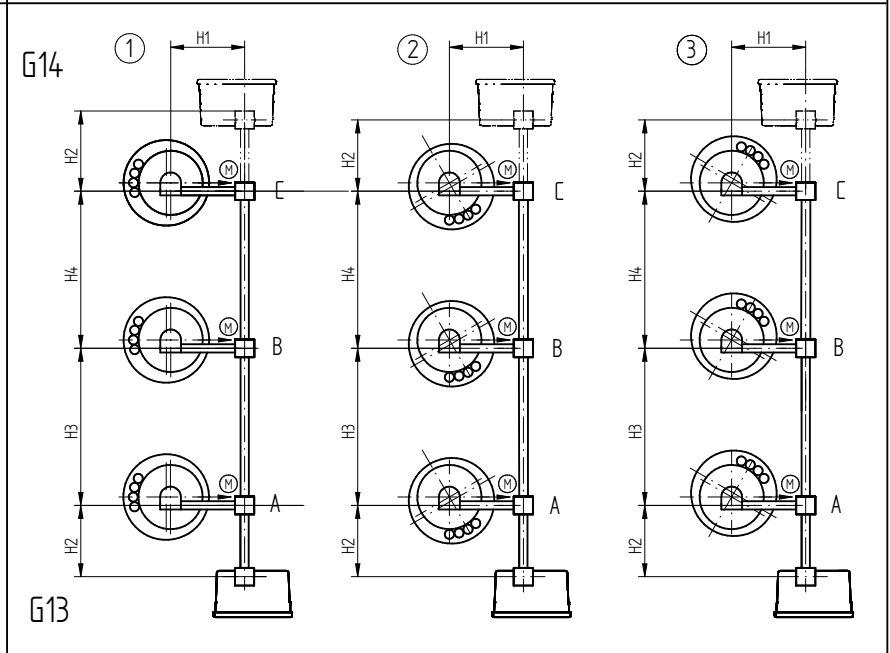
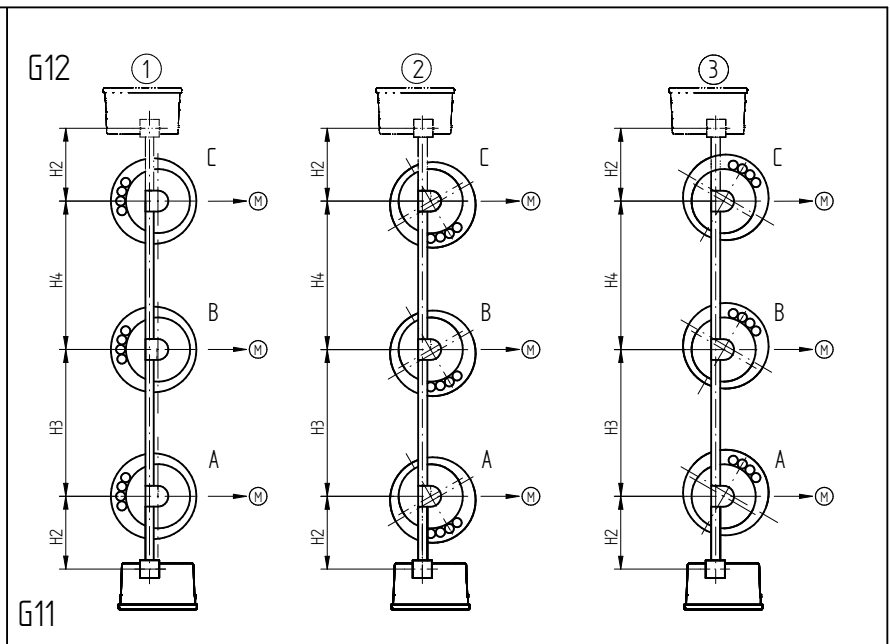
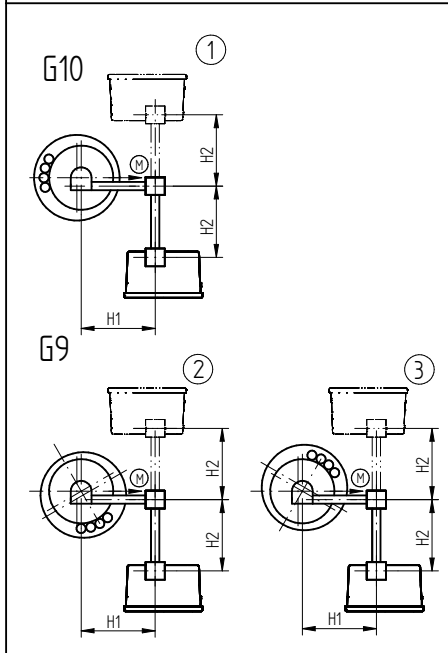
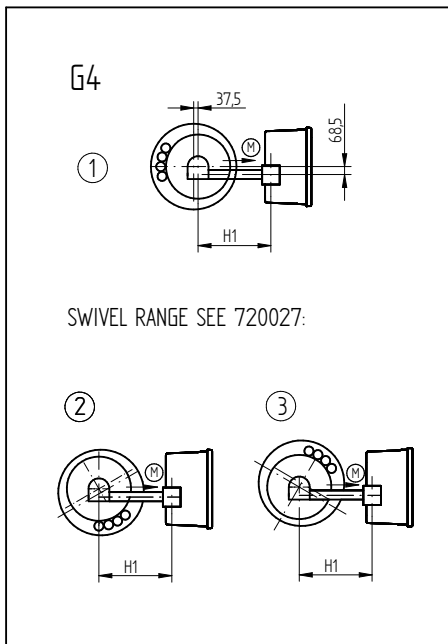

ARRANGEMENT	G4	G9, G10	G11, G12	G13, G14	
STANDARD DESIGN	■		■		
SPECIAL DESIGN		■		■	
MINIMUM DIMENSIONS <sup>1)</sup> (DETERMINED FOR MECHANICAL REASONS; NECESSARY INSULATION SPACINGS NOT CONSIDERED!)	H1	535	545	-	545
	H2	-	323	515	323
	H3 <sup>2)</sup>	-	-	840	840
	H4 <sup>2)</sup>	-	-	840	840
NOTE: 1) FOR OLTCs WITH THE CHANGE-OVER SELECTOR ATTACHED LaterALLY, THE DIMENSIONS OF THE CHANGE-OVER SELECTOR AFTER INSTALLED IN POSITION HAVE TO BE TAKEN INTO ACCOUNT (SEE THE CORRESPONDING OLTC-DIMENSION DRAWING) 2) IN GENERAL DETERMINED BY THE INSULATION SPACING BETWEEN POLES A, B, C.					
INTERMEDIATE BEARING FOR	H1 >	2254	2309	-	2309
	H2 >	-	2259	2254	2259
	H3 >	-	-	2249	2259
	H4 >	-	-	2249	2259

① ② ③ - HEAD VERSION  
 → (M) - DRIVE SIDE OF SELECTOR

DIMENSION IN mm EXCEPT AS NOTED



OLTC OILTAP® M, MS, RM, R / VACUTAP® VR®, VM®, VMS®  
 HORIZONTAL DRIVE SHAFT, CENTRIC DRIVE (LIMIT DIMENSIONS)  
 SELECTOR SIZE B/C/D/RC/RD/RDE

SERIAL NUMBER

MATERIAL NUMBER 893896DE  
 SHEET 1/1

© MASCHINENFABRIK REINHAUSEN GMBH 2018  
 THE REPRODUCTION, DISTRIBUTION AND UTILIZATION OF THIS DOCUMENT AS WELL AS THE COMMUNICATION OF ITS CONTENTS TO OTHERS WITHOUT EXPRESS AUTHORIZATION IS PROHIBITED. OFFENDERS WILL BE HELD LIABLE FOR THE PAYMENT OF DAMAGES. ALL RIGHTS RESERVED IN THE EVENT OF THE GRANT OF A PATENT, UTILITY MODEL OR DESIGN.

DFTR.	11.07.2018	DATE	NAME	DOCUMENT NO.
CHKD.	16.07.2018		BUTERUS	SED 1661250 001 03
STAND.	16.07.2018		WILHELM	CHANGE NO.
			PRODASTSCHUK	1086956
				SCALE
				1:2,5

DIMENSION  
 IN mm  
 EXCEPT AS  
 NOTED



ON-LOAD TAP-CHANGER  
 OILTAP® M, MS, R, RM AND VACUTAP® VR®, VM®, VMS®  
 WITH MOUNTING FLANGE FOR PRESSURE RELIEF DEVICE

SERIAL NUMBER

MATERIAL NUMBER  
 8951689E

SHEET  
 1/1

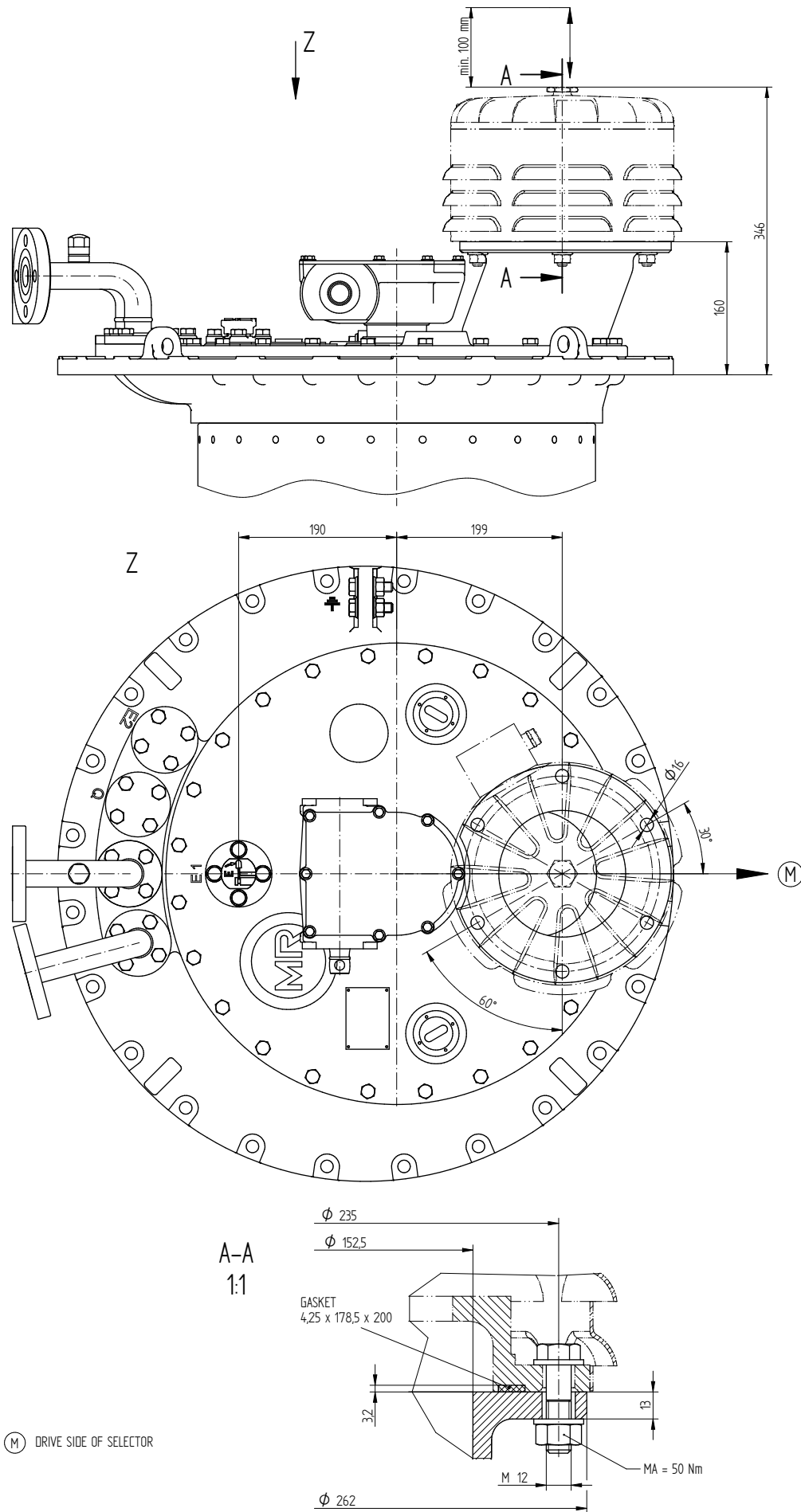

© MASCHINENFABRIK REINHAUSEN GMBH 2016  
 THE REPRODUCTION, DISTRIBUTION AND UTILIZATION OF THIS DOCUMENT AS WELL AS THE COMMUNICATION OF ITS CONTENTS TO OTHERS WITHOUT EXPRESS AUTHORIZATION IS PROHIBITED. OFFENDERS WILL BE HELD LIABLE FOR THE PAYMENT OF DAMAGES. ALL RIGHTS RESERVED IN THE EVENT OF A PATENT, UTILITY MODEL OR DESIGN.

## PIPE CONNECTION WITH TAP-CHANGE SUPERVISORY CONTROL BUSHING WITHOUT OIL FILTER UNIT

NOTICE!  
 THE VENT SCREW ② OF THE MOUNTED HOUSING ① HAS TO BE ON THE TOP

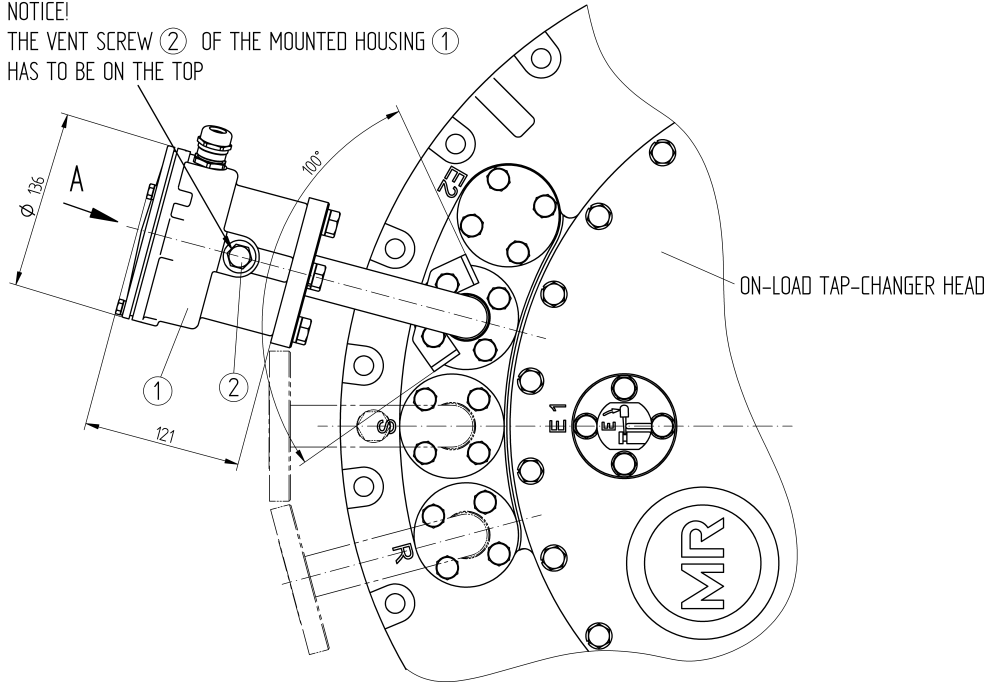

A ↻ 1:1

REPRESENTED WITHOUT COVER

M20x1.5  
 CLAMPING RANGE FOR CONNECTION CABLE:  
 EXTERNAL DIAMETER: 7 - 13 mm

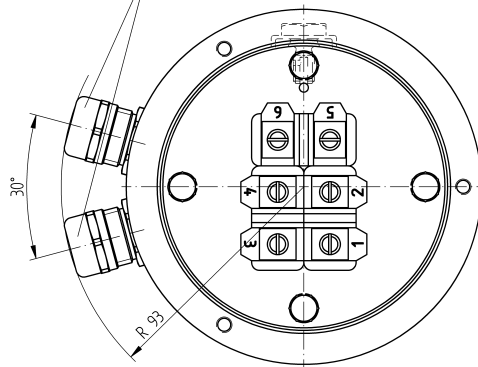

CONNECTION TERMINALS FOR TAP-CHANGE SUPERVISORY CONTROL

WIRING SEE CONNECTION DIAGRAM OF THE MOTOR-DRIVE UNIT

FUNCTION DIAGRAM FOR TAP-CHANGE SUPERVISORY CONTROL SEE MOTOR-DRIVE CONNECTION DIAGRAM

RATED CONTINUOUS CURRENT: 2A  
 RATED VOLTAGE DC/AC (50HZ): 24V ... 250V  
 DIELECTRIC STRENGTH: 1150V / 50HZ / 1 MIN.

DIELECTRIC TEST OF ALL VOLTAGE CARRYING TERMINALS TO GROUND:  
 2000V AC , 50HZ , TEST-DURATION 1 MIN.

DATE	NAME	DOCUMENT NO.
03.11.2016	RAEDLINGER	SED 2425358 001 02
04.11.2016	NERRETER	CHANGE NO.
04.11.2016	PRODASTSCHUK	1078202
DFTR.	SCALE	1:2
CHKD.		
STAND.		

DIMENSION  
 IN mm  
 EXCEPT AS  
 NOTED



ON-LOAD TAP-CHANGER VACUTAP® VM, VR  
 PIPE CONNECTION WITH TAP-CHANGE SUPERVISORY CONTROL

SERIAL NUMBER

MATERIAL NUMBER  
 7661612E

SHEET  
 1/1



## 4.4 Масляный бак контактора

© MASCHINENFABRIK REINHAUSEN GMBH 2018  
 THE REPRODUCTION, DISTRIBUTION AND UTILIZATION OF THIS DOCUMENT AS WELL AS THE COMMUNICATION OF ITS CONTENTS TO OTHERS WITHOUT EXPRESS AUTHORIZATION IS PROHIBITED. OFFENDERS WILL BE HELD LIABLE FOR THE PAYMENT OF DAMAGES. ALL RIGHTS RESERVED IN THE EVENT OF THE GRANT OF A PATENT, UTILITY MODEL OR DESIGN.

MI 351/501/601  
 MIII 350/600 D  
 POLE B  
 VMI 351/501/651

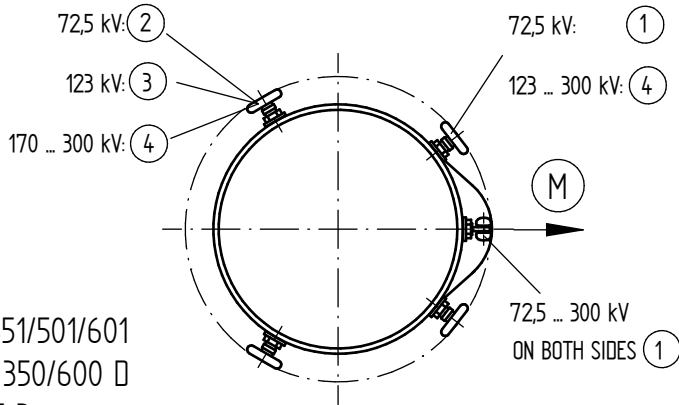

MI 603/803  
 MI 1203/1503

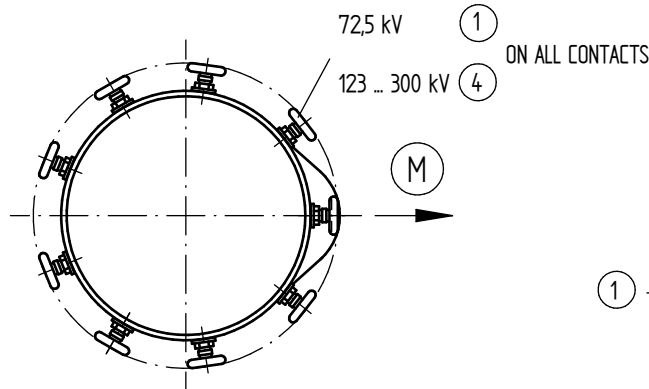

VMI 653/803  
 VMI 1203/1503

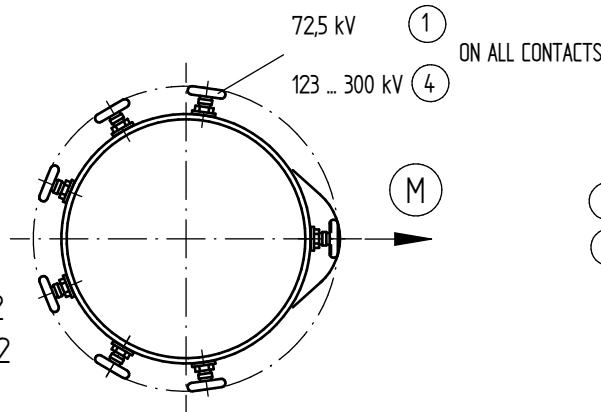

MI 502/602/802  
 MII 352/502/602  
 VMI 502/652/802  
 VMII 352/502/652

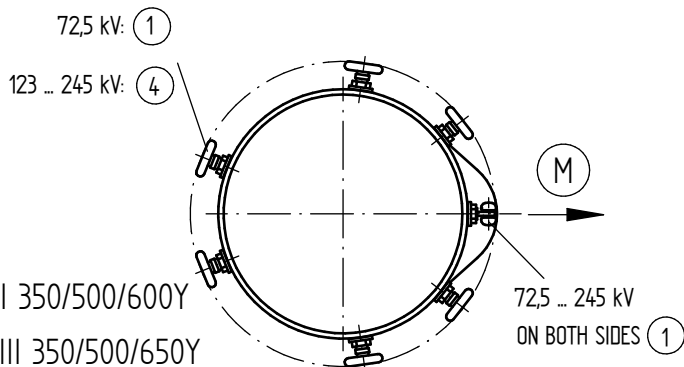

MIII 350/500/600Y  
 VMIII 350/500/650Y  
 VMSIII 400/650Y

MIII 350/500 D POLE A  
 VMIII 350/500 D POLE A

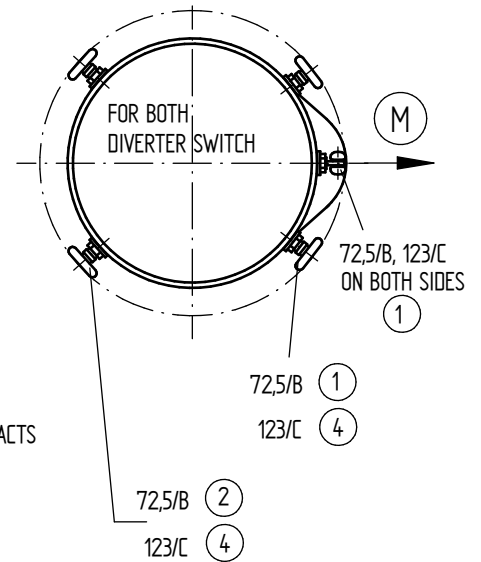

① - 056919 ( UNCOATED )

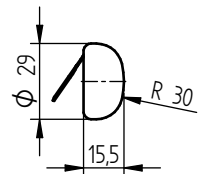

② - 016768 ( UNCOATED )

③ - 067620 ( COATED )

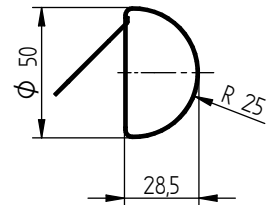

④ - 066845 ( COATED )

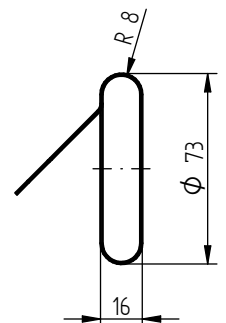
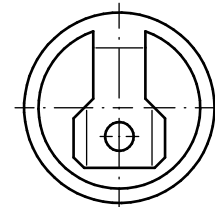

WITH THE CURRENT TAKE-OFF RINGS SCREENING CAPS ① ARE USED TO ATTACH THE LOWER SCREENING RING ( 170 ... 300 kV )

DATE	DOCUMENT NO.
13.07.2018	SED 1668294_001 02
NAME	SCALE
BUTERUS	-
WILHELM	CHANGE NO.
PRODASTSCHUK	1086956
DATE	DOCUMENT NO.
16.07.2018	SED 1668294_001 02
NAME	SCALE
WILHELM	-
PRODASTSCHUK	CHANGE NO.
16.07.2018	1086956

DIMENSION  
 IN mm  
 EXCEPT AS  
 NOTED



ON-LOAD TAP-CHANGER OILTAP® M / VACUTAP® VM®, VMS®  
 SCREENINGS ON OIL COMPARTMENT TERMINALS

SERIAL NUMBER

MATERIAL NUMBER  
 7303362E

SHEET  
 1 / 1

## 4.5 Избиратель

© MASCHINENFABRIK REINHAUSEN GMBH 2018  
 THE REPRODUCTION, DISTRIBUTION AND UTILIZATION OF THIS DOCUMENT AS WELL AS THE COMMUNICATION OF ITS CONTENTS TO OTHERS WITHOUT EXPRESS AUTHORIZATION IS PROHIBITED. OFFENDERS WILL BE HELD LIABLE FOR THE PAYMENT OF DAMAGES. ALL RIGHTS RESERVED IN THE EVENT OF THE GRANT OF A PATENT, UTILITY MODEL OR DESIGN.

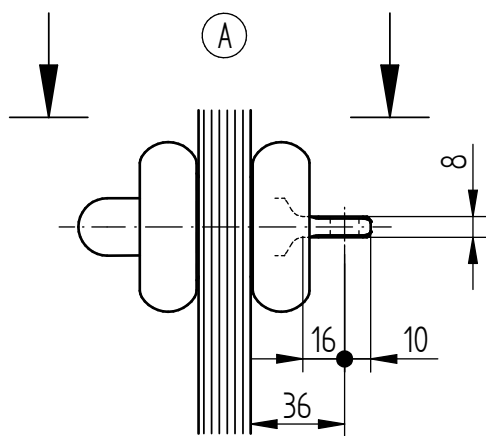

THROUGH-HOLE VERTICAL

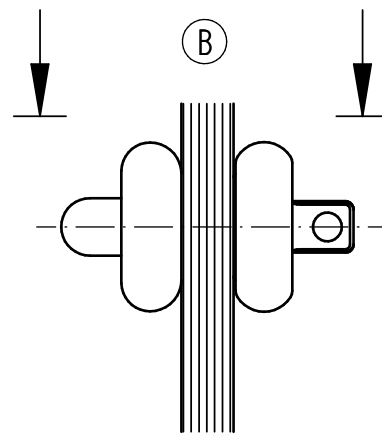
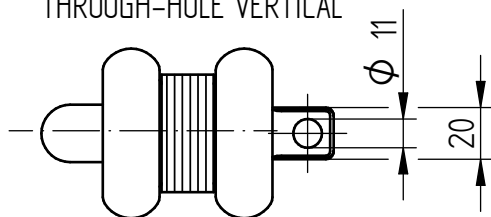

THROUGH-HOLE HORIZONTAL

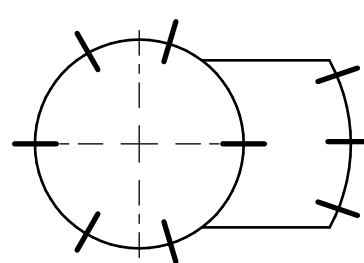
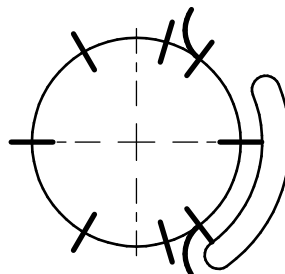
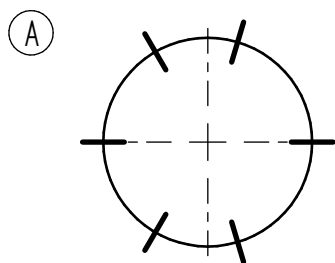
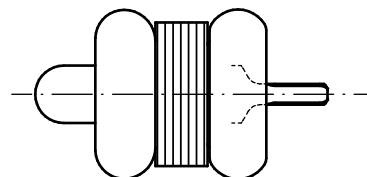

- M III 350 / 500 / 600Y - 0
- VM III 350 / 500 / 650Y - 0
- VMS III 400 / 650Y - C - 0
- M II 352 / 502 / 602 - 0
- VM II 352 / 502 / 652 - 0
- M I 351 / 501 / 601 - 0
- VM I 351 / 501 / 651 - 0

- M III 350 / 500 / 600Y - W
- VM III 350 / 500 / 650Y - W
- VMS III 400 / 650Y - C - W
- M II 352 / 502 / 602 - W
- VM II 352 / 502 / 652 - W
- M I 351 / 501 / 601 - W
- VM I 351 / 501 / 651 - W

- M III 350 / 500 / 600Y - G
- VM III 350 / 500 / 650Y - G
- VMS III 400 / 650Y - C - G
- M II 352 / 502 / 602 - G
- VM II 352 / 502 / 652 - G
- M I 351 / 501 / 601 - G
- VM I 351 / 501 / 651 - G

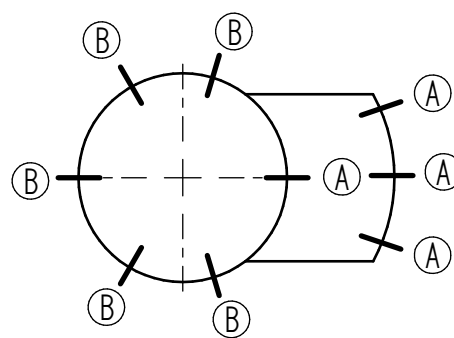
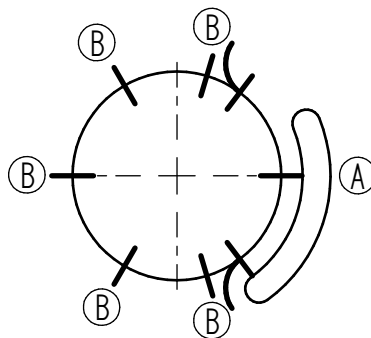
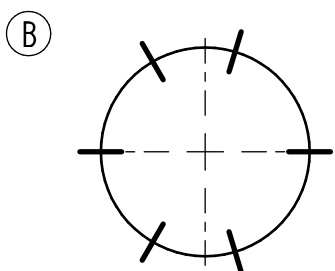

- M I 802 - 0
- VM I 802 - 0
- VM I 1002 - 0
- M I 1203 / 1503 - 0
- VM I 1203 / 1503 - 0

- M I 802 - W
- VM I 802 - W
- VM I 1002 - W
- M I 1203 / 1503 - W
- VM I 1203 / 1503 - W

- M I 802 - G
- VM I 802 - G
- VM I 1002 - G
- M I 1203 / 1503 - G
- VM I 1203 / 1503 - G

(A) + (B)

DATE	NAME	DOCUMENT NO.
13.07.2018	BUJERUS	SED 1706800 000 03
16.07.2018	WILHELM	CHANGE NO.
16.07.2018	PRODASTSCHUK	1086956
SCALE		1:2

DIMENSION  
IN mm  
EXCEPT AS  
NOTED



OLTC OILTAP® M / VACUTAP® VM®, VMS®-C  
 INSTALLATION POSITION OF SELECTOR CONNECTION CONTACTS  
 M-SELECTOR SIZE B/C/D/E

SERIAL NUMBER

MATERIAL NUMBER  
890477BE

SHEET  
1 / 1

© MASCHINENFABRIK REINHAUSEN GMBH 2018  
 THE REPRODUCTION, DISTRIBUTION AND UTILIZATION OF THIS DOCUMENT AS WELL AS THE COMMUNICATION OF ITS CONTENTS TO OTHERS WITHOUT EXPRESS AUTHORIZATION IS PROHIBITED. OFFENDERS WILL BE HELD LIABLE FOR THE PAYMENT OF DAMAGES. ALL RIGHTS RESERVED IN THE EVENT OF THE GRANT OF A PATENT, UTILITY MODEL OR DESIGN.

SELECTOR WITHOUT CHANGE-OVER SELECTOR:

SELECTOR WITH REVERSING CHANGE-OVER SELECTOR:  
 REPRESENTATION APPLIES TO TYPES M/ VM®/ VMS®-C/ VRC/ VRE III Y AND M/ VM®/ VRC/ VRE II.  
 THE UPPER AND LOWER SELECTOR PLANE ARE INTERCHANGED IN TYPES M/ VM®/ VRC/ VRE I AND VRC I HD/ VRE I HD.

SELECTOR WITH COARSE CHANGE-OVER SELECTOR:

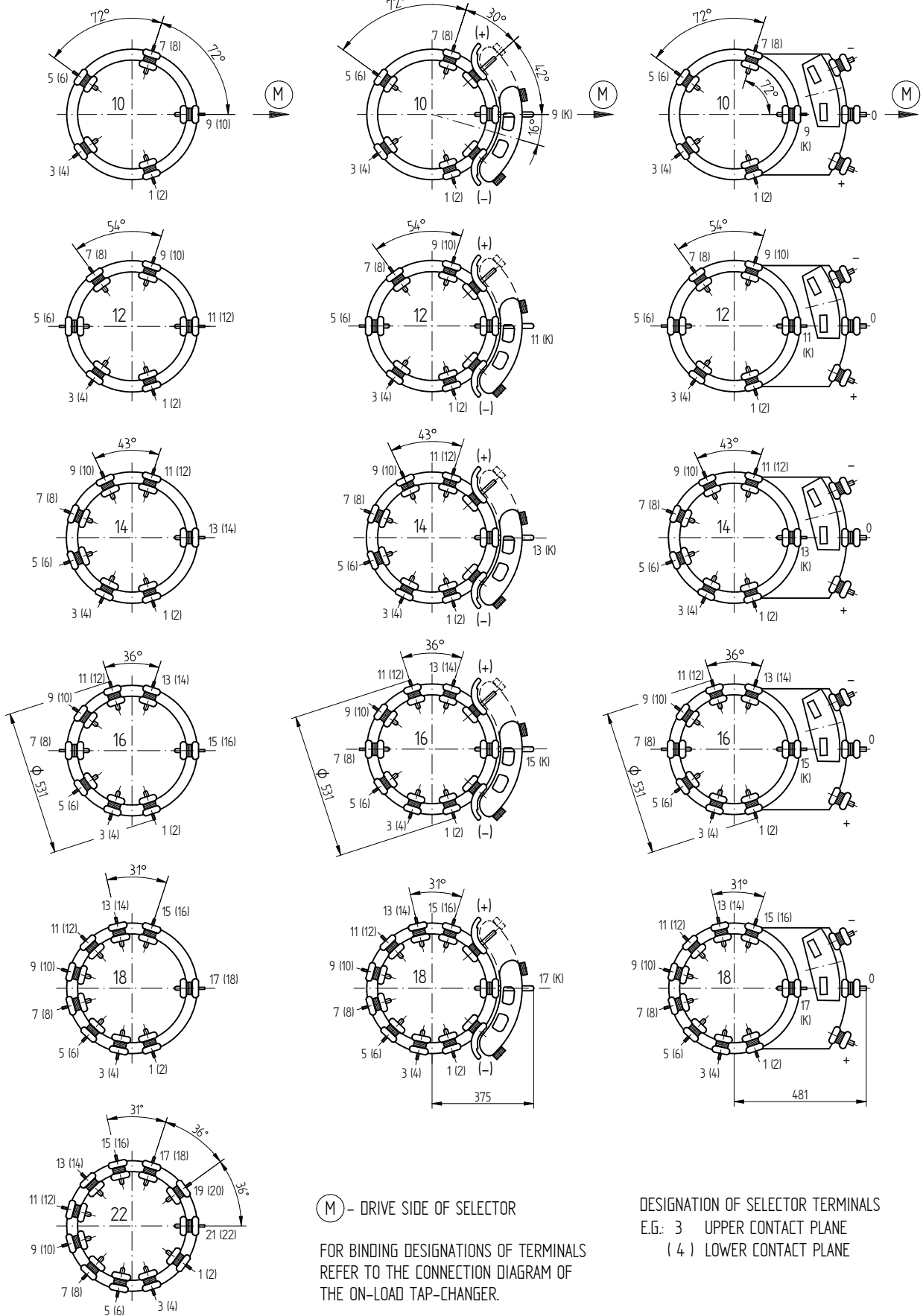

(M) - DRIVE SIDE OF SELECTOR

FOR BINDING DESIGNATIONS OF TERMINALS REFER TO THE CONNECTION DIAGRAM OF THE ON-LOAD TAP-CHANGER.

DESIGNATION OF SELECTOR TERMINALS  
 E.G.: 3 UPPER CONTACT PLANE  
 (4) LOWER CONTACT PLANE

DATE	13.07.2018	DOCUMENT NO.	SED 1050444 001 05
DFTR.	16.07.2018	NAME	BUTERUS
CHKD.	16.07.2018	CHANGE NO.	1086956
STAND.	16.07.2018	SCALE	1:10
		PRODASTSCHUK	

DIMENSION  
 IN mm  
 EXCEPT AS  
 NOTED



OLTC OILTAP® M / VACUTAP® VM®, VMS®-C, VRC, VRE  
 ARRANGEMENT OF CONTACTS AT SELECTOR  
 M-SELECTOR SIZE B/C/D/DE - SELECTOR PITCH 10 ... 22

SERIAL NUMBER

MATERIAL NUMBER  
 8980136E

SHEET  
 1/1

© MASCHINENFABRIK REINHAUSEN GMBH 2018  
 THE REPRODUCTION, DISTRIBUTION AND UTILIZATION OF THIS DOCUMENT AS WELL AS THE COMMUNICATION OF ITS CONTENTS TO OTHERS WITHOUT EXPRESS AUTHORIZATION IS PROHIBITED. OFFENDERS WILL BE HELD LIABLE FOR THE PAYMENT OF DAMAGES. ALL RIGHTS RESERVED IN THE EVENT OF THE GRANT OF A PATENT, UTILITY MODEL OR DESIGN.

## REVERSING CHANGE-OVER SELECTOR

REPRESENTATION OF SELECTOR, 12-PITCH

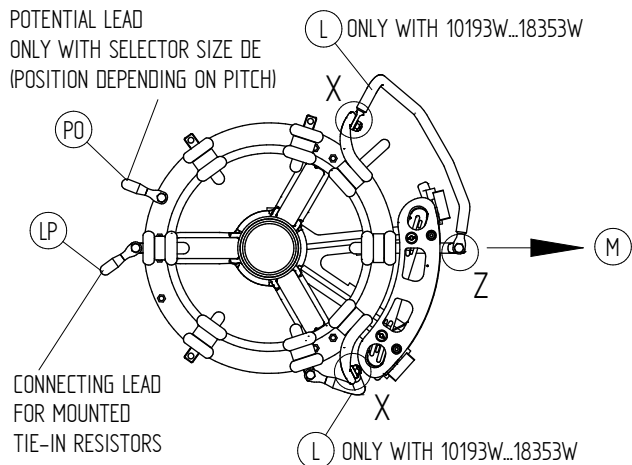

LEAD PROFILE (LP)

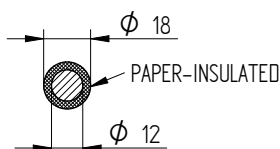

LEAD PROFILE (PO), (L) ONLY WITH SELECTOR SIZE DE

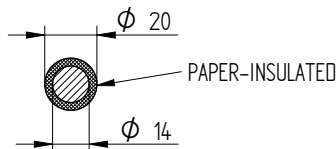

LEAD PROFILE (L) WITH SELECTOR SIZE B, C, D

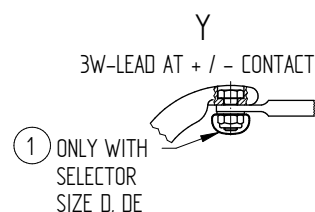
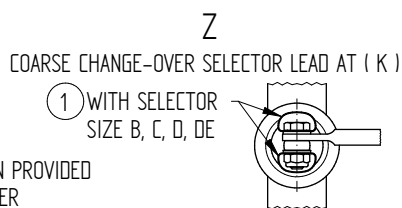
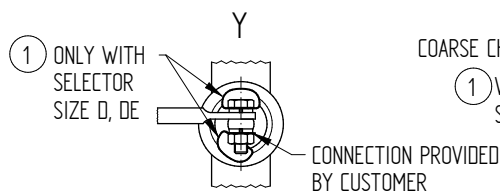

PARALLEL BRIDGES ARRANGEMENT OF CONTACTS A

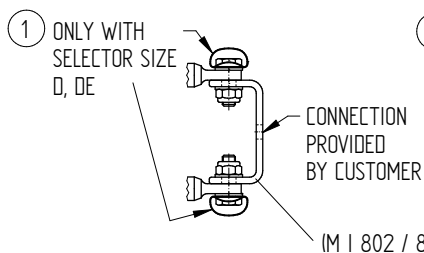

PARALLEL BRIDGES ARRANGEMENT OF CONTACTS B

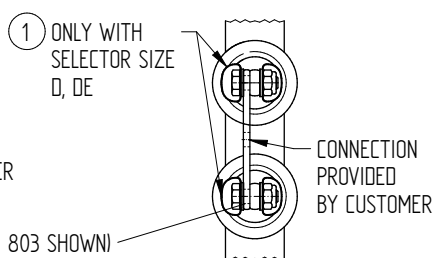

PARALLEL BRIDGES AT + / - CONTACT (WITH REVERSING CHANGE-OVER SELECTOR)



PARALLEL BRIDGES ARRANGEMENT OF CONTACTS A WITH (LP)

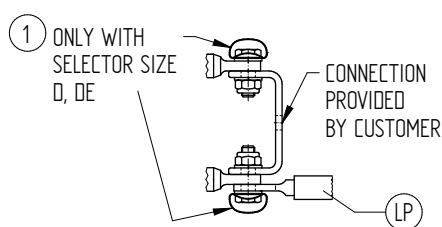

PARALLEL BRIDGES ARRANGEMENT OF CONTACTS B WITH (LP)

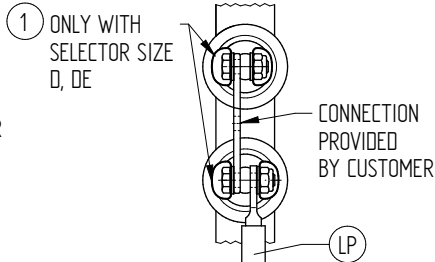

CONNECTION CONTACT (STANDARD) WITH (LP)

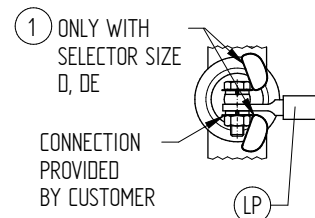

(M) DRIVE SIDE OF SELECTOR  
(LP) (PO) (L) CONNECTING LEADS

NOTICE: WITH SELECTOR SIZE D AND DE SCREENING CAPS (1) ARE UNMOUNTED DELIVERED TO ATTACH THE LEADS, PROVIDED BY CUSTOMER, TO THE TAPINGS OF THE TAP WINDING.

## COARSE CHANGE-OVER SELECTOR

REPRESENTATION OF SELECTOR, 12-PITCH

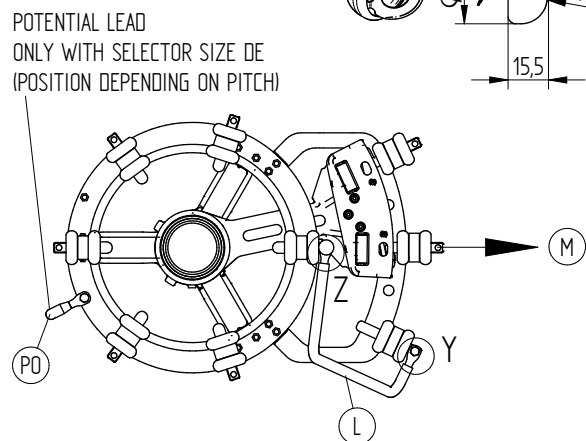

DIMENSION IN mm EXCEPT AS NOTED



OLTC OILTAP® M, RM / VACUTAP® VRC/VRE, VM®, VMS®-C SCREENINGS AT TAP SELECTOR AND CHANGE-OVER SELECTOR M-SELECTOR SIZE B/C/D/DE

SERIAL NUMBER

MATERIAL NUMBER 7303353E SHEET 1/1

DOCUMENT NO.	1668279 001 03	SCALE	1
NAME	BUTERUS WILHELM	CHANGE NO.	1086956
DATE	13.07.2018	PRODASTSCHUK	
DFTR.	16.07.2018		
CHKD.	16.07.2018		
STAND.	16.07.2018		

© MASCHINENFABRIK REINHAUSEN GMBH 2018  
 THE REPRODUCTION, DISTRIBUTION AND UTILIZATION OF THIS DOCUMENT AS WELL AS THE COMMUNICATION OF ITS CONTENTS TO OTHERS WITHOUT EXPRESS AUTHORIZATION IS PROHIBITED. OFFENDERS WILL BE HELD LIABLE FOR THE PAYMENT OF DAMAGES. ALL RIGHTS RESERVED IN THE EVENT OF THE GRANT OF A PATENT, UTILITY MODEL OR DESIGN.

### REVERSING CHANGE-OVER SELECTOR

E - F (TYPE M / VM / VMS-C ) AND D - D (TYPE VRC / VRE / VRC I HD / VRE I HD / VRS / VRM)  
 REPRESENTATION APPLIES TO 12-PITCH SELECTOR

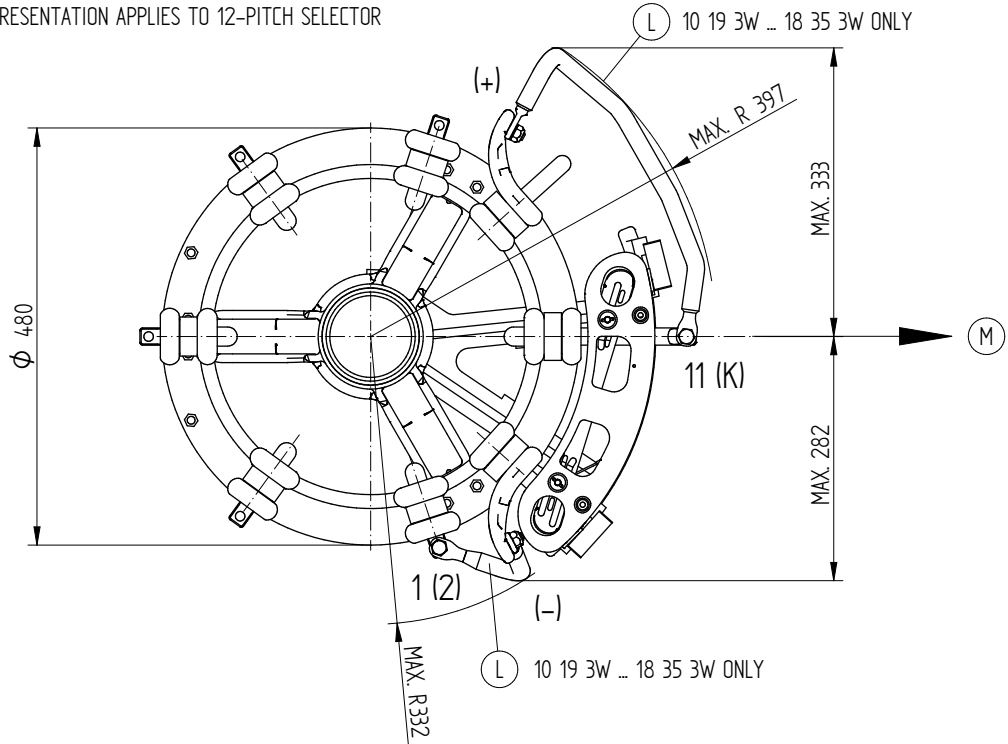

### COARSE CHANGE-OVER SELECTOR

G - H (TYPE M / VM / VMS-C ) AND E - E (TYPE VRC / VRE / VRC I HD / VRE I HD / VRS / VRM)  
 REPRESENTATION APPLIES TO 12-PITCH SELECTOR

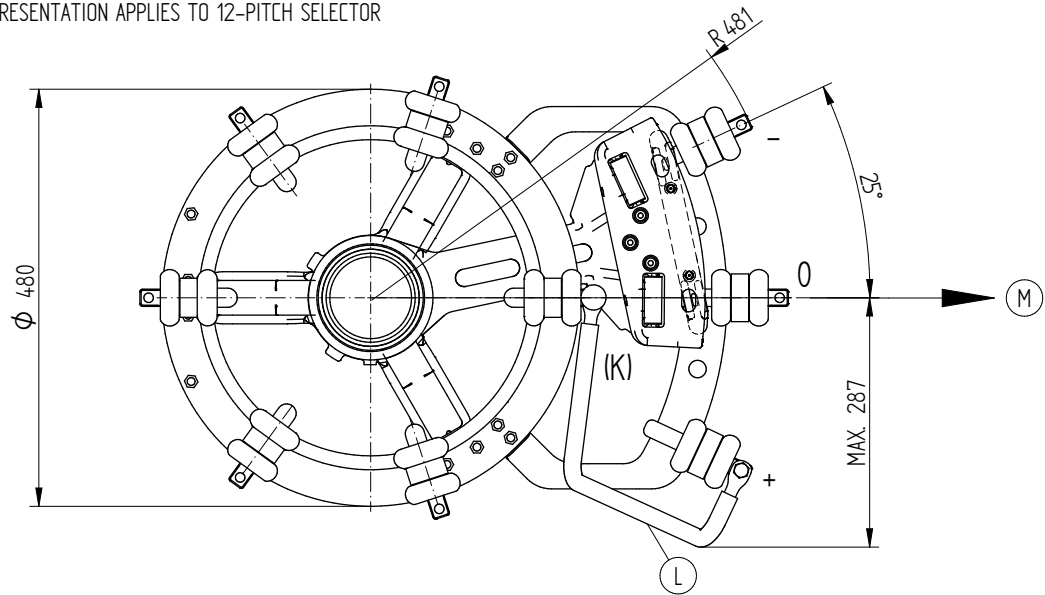

(L) SELECTOR SIZE B, C, D

(L) SELECTOR SIZE DE

(M) DRIVE SIDE OF SELECTOR

(L) CONNECTING LEADS

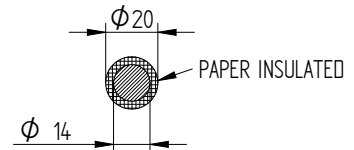
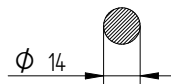

THE DETAILED CONNECTION DIAGRAM IS BINDING FOR THE DESIGNATION OF THE CONNECTION CONTACTS

DATE	NAME	DOCUMENT NO.
DFTR. 13.07.2018	BUTERUS	SED 1474939 000 06
CHKD. 16.07.2018	WILHELM	CHANGE NO.
STAND. 16.07.2018	PRODASTSCHUK	1086956
		SCALE 1:3

DIMENSION  
IN mm  
EXCEPT AS  
NOTED



OLT C OILTAP® M / VACUTAP® VM®, VMS®-C, VRC, VRE, VRS, VRM  
 CONNECTING LEAD 3W AND 1G / 3G  
 M-SELECTOR SIZE B/C/D/DE

SERIAL NUMBER

MATERIAL NUMBER  
7235904E

SHEET  
1/1

© MASCHINENFABRIK REINHAUSEN GMBH 2015  
 THE REPRODUCTION, DISTRIBUTION AND UTILIZATION OF THIS DOCUMENT AS WELL AS THE COMMUNICATION OF ITS CONTENTS TO OTHERS WITHOUT EXPRESS AUTHORIZATION IS PROHIBITED. OFFENDERS WILL BE HELD LIABLE FOR THE PAYMENT OF DAMAGES. ALL RIGHTS RESERVED IN THE EVENT OF THE GRANT OF A PATENT, UTILITY MODEL OR DESIGN.

DATE	NAME	DOCUMENT NO.
DFTR. 19.08.2015	RAEDLINGER	SED 26/13347_001 01
CHKD. 21.08.2015	TKBIRKMAN	CHANGE NO.
STAND. 24.08.2015	KLEYN	1066507
		SCALE
		-

DIMENSION  
IN mm  
EXCEPT AS  
NOTED



OLTC OILTAP® M | 351/501/601, RM | 601  
 OLTC VACUTAP® VM | 351/501/651, VRC | 401/551/701, VRE | 701  
 CONTACT ARRANGEMENT ON SELECTOR FOR SELECTOR SIZE B,C,D,DE

SERIAL NUMBER

MATERIAL NUMBER  
8911088E

SHEET  
1/1

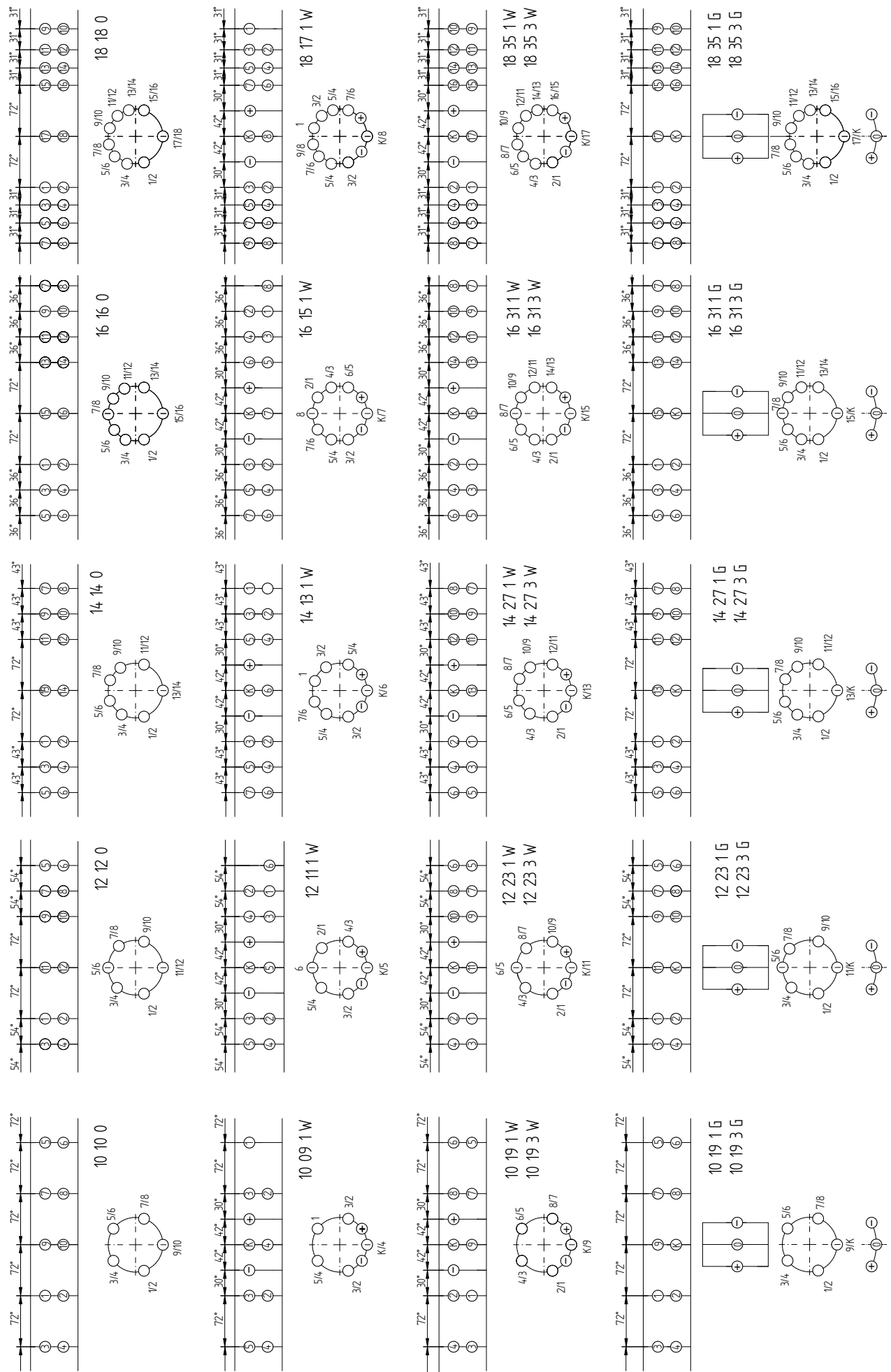



© MASCHINENFABRIK REINHAUSEN GMBH 2015  
 THE REPRODUCTION, DISTRIBUTION AND UTILIZATION OF THIS DOCUMENT AS WELL AS THE COMMUNICATION OF ITS CONTENTS TO OTHERS WITHOUT EXPRESS AUTHORIZATION IS PROHIBITED. OFFENDERS WILL BE HELD LIABLE FOR THE PAYMENT OF DAMAGES. ALL RIGHTS RESERVED IN THE EVENT OF THE GRANT OF A PATENT, UTILITY MODEL OR DESIGN.

DATE	NAME	DOCUMENT NO.
19.08.2015	RAEDLINGER	SED 2613129 001 01
21.08.2015	TKBIRKMANN	CHANGE NO.
24.08.2015	KLEYN	1066507
		SCALE
		-

DIMENSION  
 IN mm  
 EXCEPT AS  
 NOTED



ON-LOAD TAP-CHANGER OILTAP® M | 802  
 ON-LOAD TAP-CHANGER VACUTAP® VM | 802/1002, VRC | 1001, VRE | 1001  
 CONTACT ARRANGEMENT ON SELECTOR FOR SELECTOR SIZE B,C,D,DE

SERIAL NUMBER

MATERIAL NUMBER  
 8911105E

SHEET  
 1/1

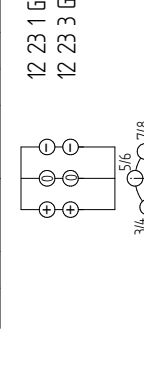
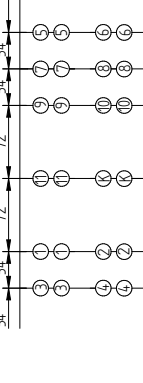
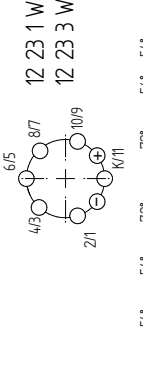
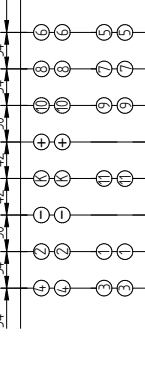
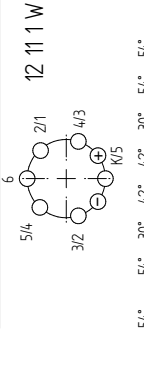
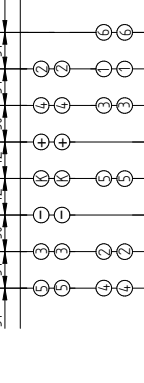
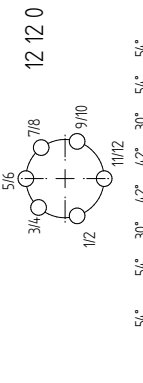
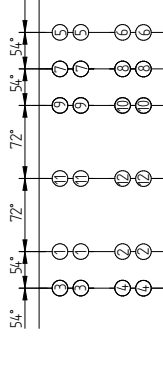
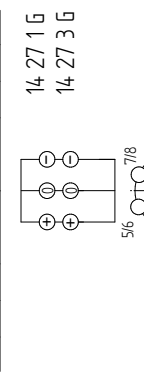
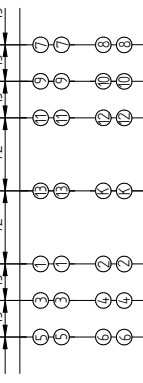
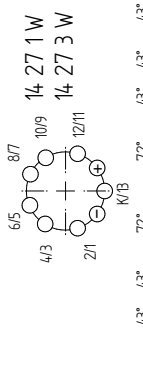
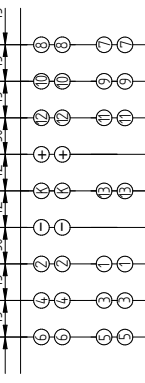
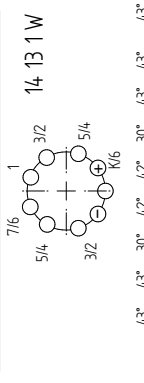
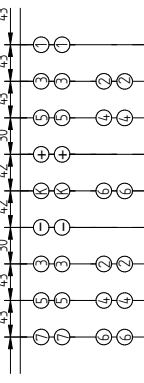
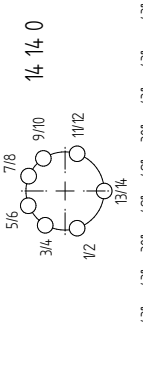
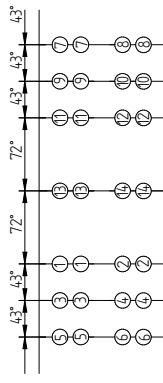
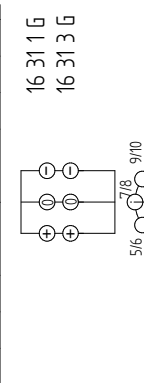
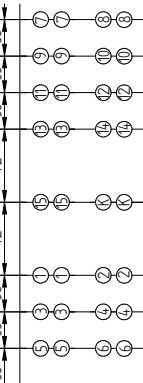
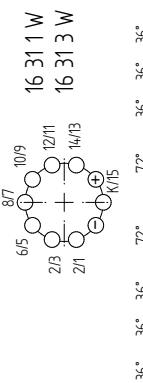
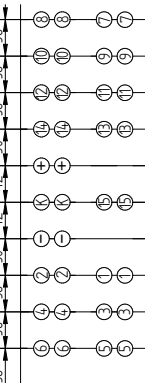
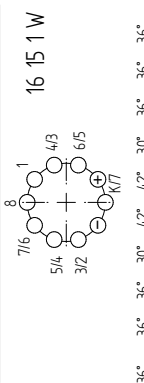
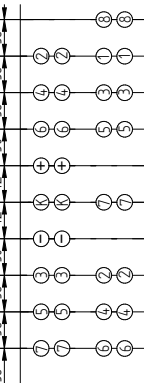
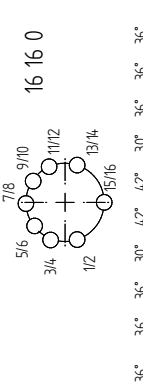
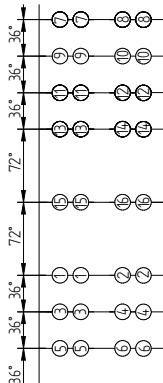
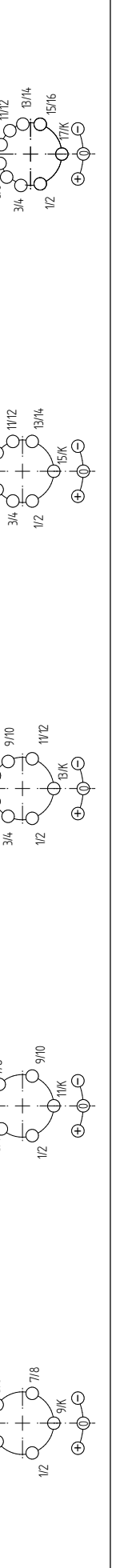
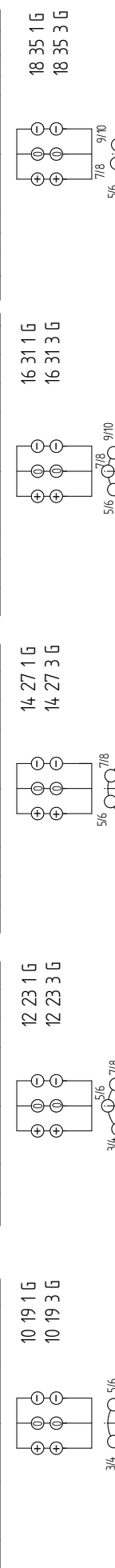
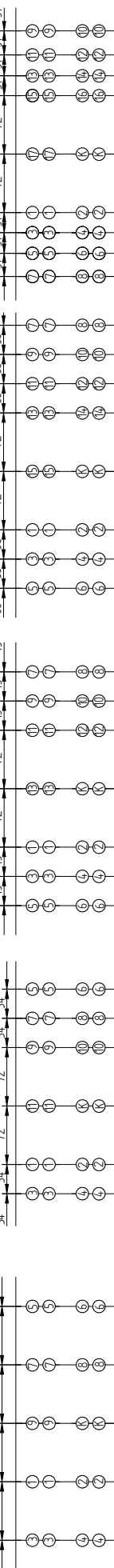
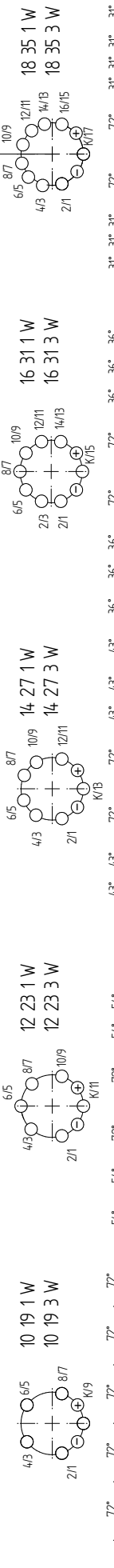
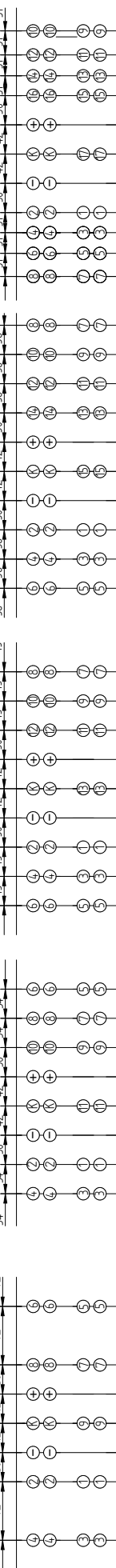
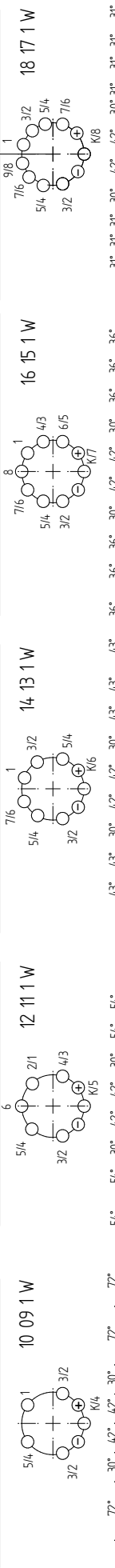
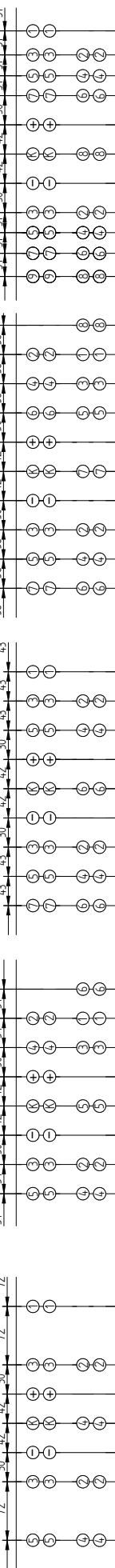
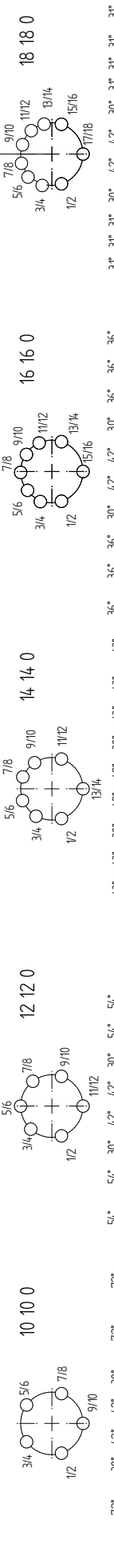
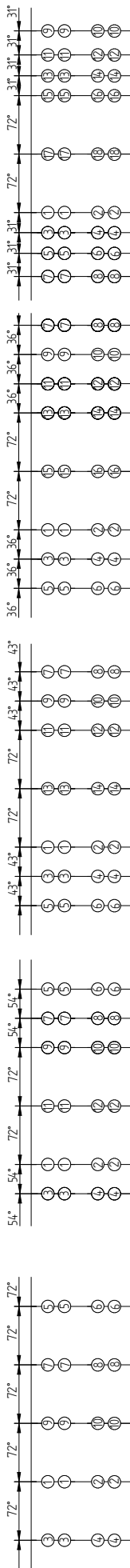

© MASCHINENFABRIK REINHAUSEN GMBH 2015  
 THE REPRODUCTION, DISTRIBUTION AND UTILIZATION OF THIS DOCUMENT AS WELL AS THE COMMUNICATION OF ITS CONTENTS TO OTHERS WITHOUT EXPRESS AUTHORIZATION IS PROHIBITED. OFFENDERS WILL BE HELD LIABLE FOR THE PAYMENT OF DAMAGES. ALL RIGHTS RESERVED IN THE EVENT OF THE GRANT OF A PATENT, UTILITY MODEL OR DESIGN.

DFTR.	DATE	NAME	DOCUMENT NO.
CHKD.	19.08.2015	RAEDLINGER	SED 26/15953 001 01
STAND.	21.08.2015	TKBIRKMANN	CHANGE NO.
	24.08.2015	KLEYN	1066507
			SCALE
			-

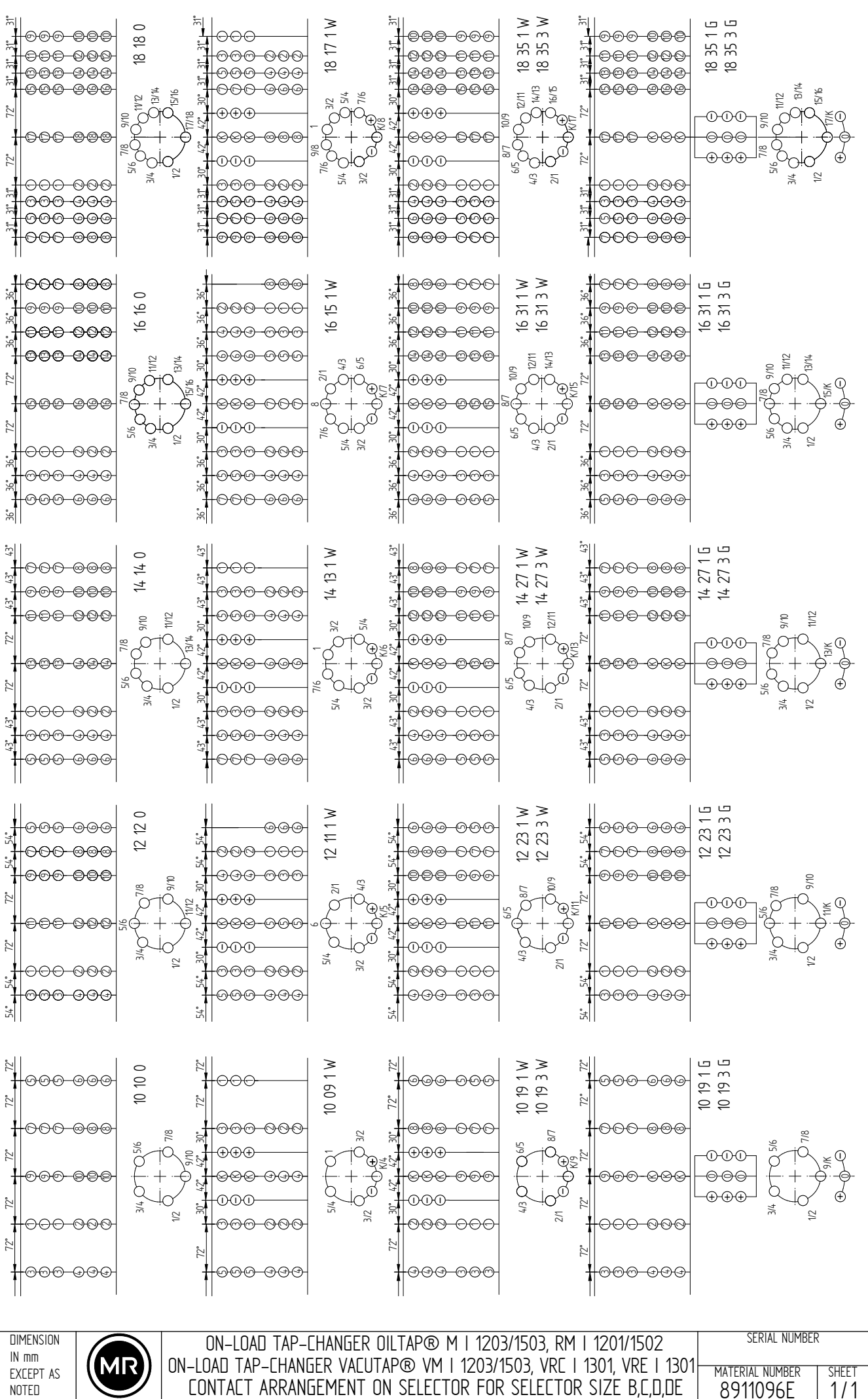

DIMENSION  
 IN mm  
 EXCEPT AS  
 NOTED



ON-LOAD TAP-CHANGER OILTAP® M | 1203/1503, RM | 1201/1502  
 ON-LOAD TAP-CHANGER VACUTAP® VM | 1203/1503, VRC | 1301, VRE | 1301  
 CONTACT ARRANGEMENT ON SELECTOR FOR SELECTOR SIZE B,C,D,DE

SERIAL NUMBER	
MATERIAL NUMBER	SHEET
8911096E	1/1

© MASCHINENFABRIK REINHAUSEN GMBH 2018

THE REPRODUCTION, DISTRIBUTION AND UTILIZATION OF THIS DOCUMENT AS WELL AS THE COMMUNICATION OF ITS CONTENTS TO OTHERS WITHOUT EXPRESS AUTHORIZATION IS PROHIBITED. OFFENDERS WILL BE HELD LIABLE FOR THE PAYMENT OF DAMAGES. ALL RIGHTS RESERVED IN THE EVENT OF THE GRANT OF A PATENT, UTILITY MODEL OR DESIGN.

DATE	NAME	DOCUMENT NO.
DfTR. 13.07.2018	BUTERUS	SED 261976 001 02
CHKD. 16.07.2018	WILHELM	CHANGE NO.
STANDJ. 16.07.2018	PRODASTSCHUK	1086956
		SCALE
		-

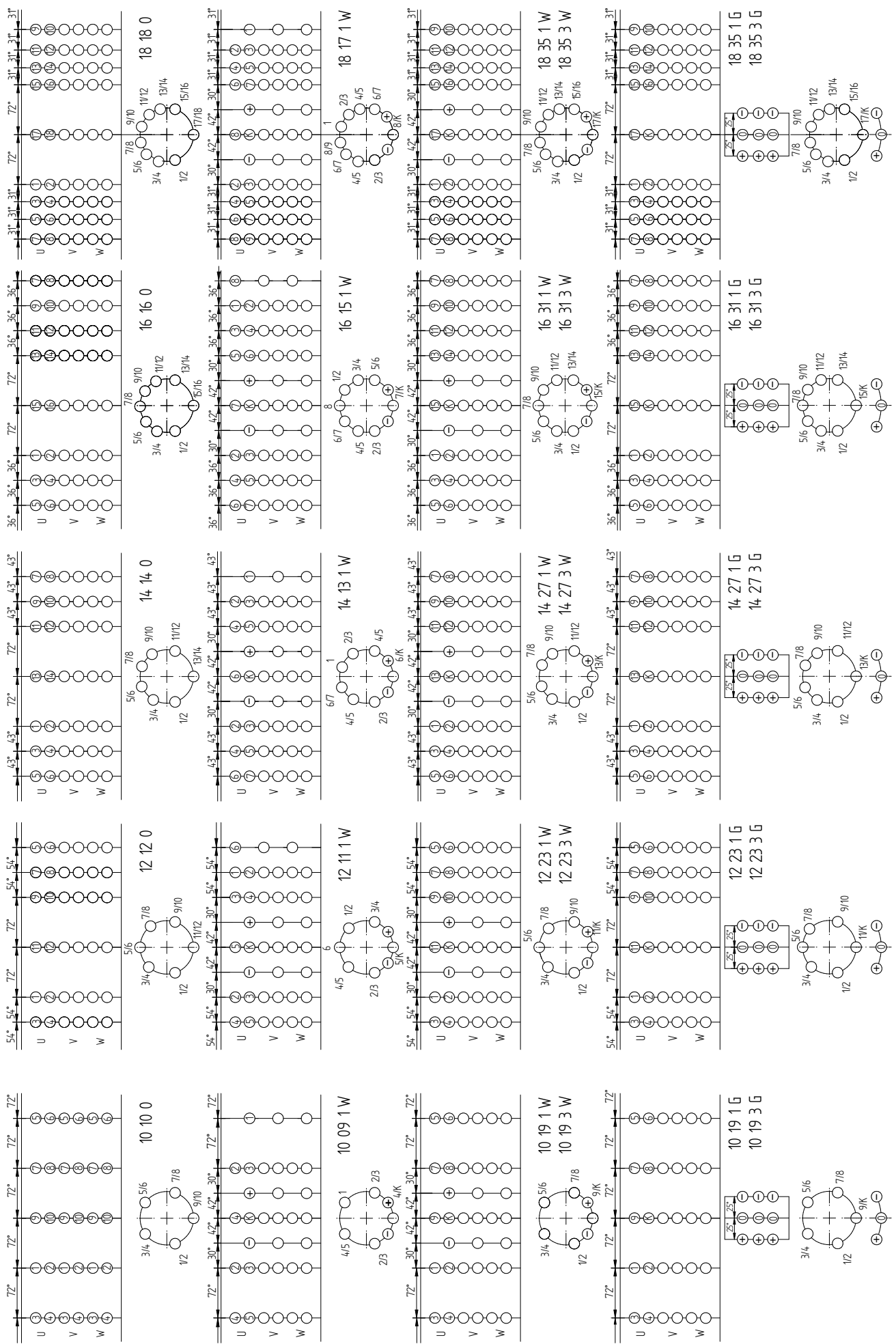

DIMENSION  
IN mm  
EXCEPT AS  
NOTED



OLTC VACUTAP® VM® III 350/500/650, VMS® III 400/650 - C  
VRC III 400/550/700, VRE III 700 / OILTAP® M III 350/500/600, RM III 600  
CONTACT ARRANGEMENT M-SELECTOR SIZE B/C/D/DE

SERIAL NUMBER	
MATERIAL NUMBER	SHEET
8911076E	1/1

© MASCHINENFABRIK REINHAUSEN GMBH 2018  
 THE REPRODUCTION, DISTRIBUTION AND UTILIZATION OF THIS DOCUMENT AS WELL AS THE COMMUNICATION OF ITS CONTENTS TO OTHERS WITHOUT EXPRESS AUTHORIZATION IS PROHIBITED. OFFENDERS WILL BE HELD LIABLE FOR THE PAYMENT OF DAMAGES. ALL RIGHTS RESERVED IN THE EVENT OF A PATENT, UTILITY MODEL OR DESIGN.

DATE	NAME	DOCUMENT NO.
DFTR. 13.07.2018	BUTERUS	SED 1708618 000 03
CHKD. 16.07.2018	WILHELM	CHANGE NO. SCALE
STAND. 16.07.2018	PRODASTSCHUK	1086956 15

DIMENSION  
 IN mm  
 EXCEPT AS  
 NOTED



ON-LOAD TAP-CHANGER OILTAP® M / VACUTAP® VM®, VMS®-C  
 SELECTOR BASE WITH HOLE Ø20 AND Ø13  
 M-SELECTOR SIZE B/C/D/DE

SERIAL NUMBER	
MATERIAL NUMBER 7256494E	SHEET 1 / 1

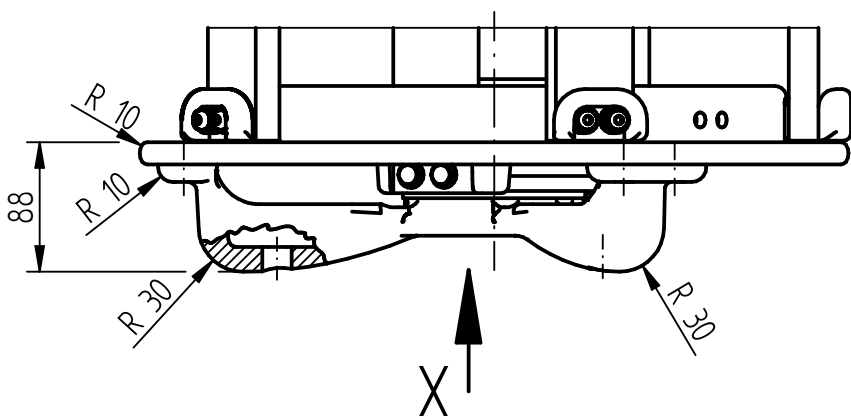

(M) DRIVE SIDE OF SELECTOR

R	D	SELECTOR BASE
147	20	097251
160	13	097252

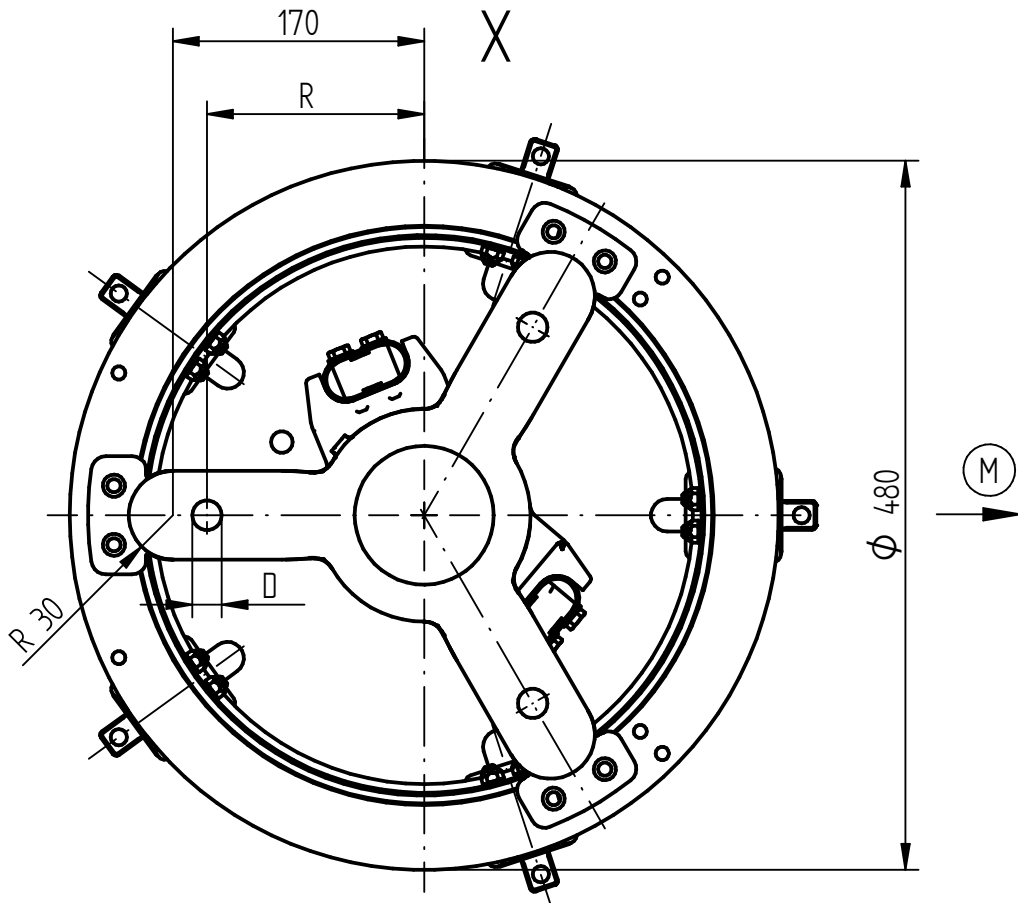

© MASCHINENFABRIK REINHAUSEN GMBH 2018  
 THE REPRODUCTION, DISTRIBUTION AND UTILIZATION OF THIS DOCUMENT AS WELL AS THE COMMUNICATION OF ITS CONTENTS TO OTHERS WITHOUT EXPRESS AUTHORIZATION IS PROHIBITED. OFFENDERS WILL BE HELD LIABLE FOR THE PAYMENT OF DAMAGES. ALL RIGHTS RESERVED IN THE EVENT OF THE GRANT OF A PATENT, UTILITY MODEL OR DESIGN.

DATE	NAME	DOCUMENT NO.
DFTR. 13.07.2018	BUTERUS	SED 1708547 000 03
CHKD. 16.07.2018	WILHELM	CHANGE NO. SCALE
STAND. 16.07.2018	PRODASTSCHUK	1086956 15

DIMENSION  
 IN mm  
 EXCEPT AS  
 NOTED



OLT<sup>®</sup> OILTAP<sup>®</sup> M / VACUTAP<sup>®</sup> VM<sup>®</sup>, VMS<sup>®</sup>-C, VRC, VRE  
 ADDITIONAL SCREENING ON SELECT OR BASE - REVERSING COS  
 M-SELECTOR SIZE B/C/D/DE

SERIAL NUMBER	
MATERIAL NUMBER 8939344E	SHEET 1 / 1

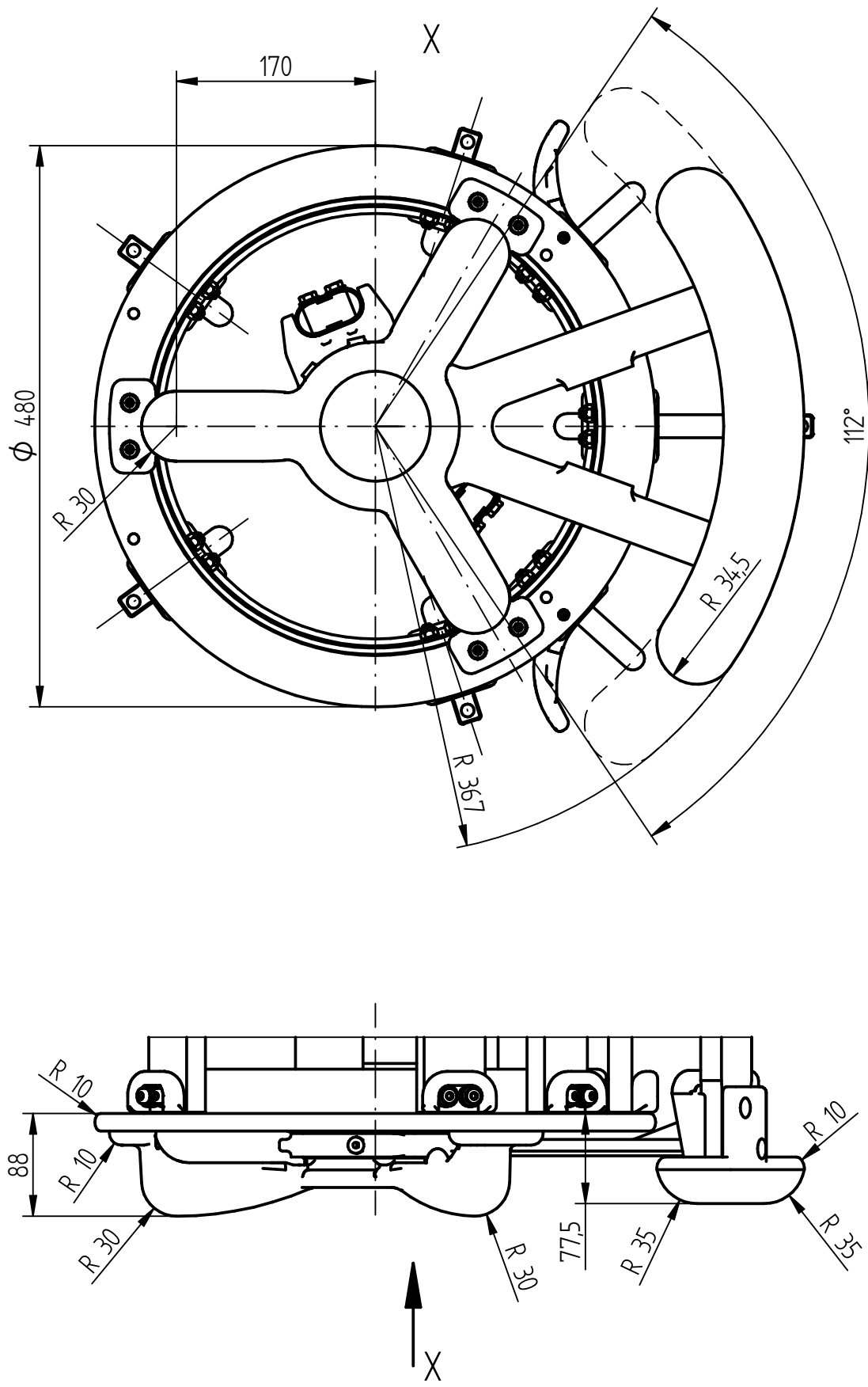

© MASCHINENFABRIK REINHAUSEN GMBH 2018  
 THE REPRODUCTION, DISTRIBUTION AND UTILIZATION OF THIS DOCUMENT AS WELL AS THE COMMUNICATION OF ITS CONTENTS TO OTHERS WITHOUT EXPRESS AUTHORIZATION IS PROHIBITED. OFFENDERS WILL BE HELD LIABLE FOR THE PAYMENT OF DAMAGES. ALL RIGHTS RESERVED IN THE EVENT OF THE GRANT OF A PATENT, UTILITY MODEL OR DESIGN.

DATE	NAME	DOCUMENT NO.
DFTR. 13.07.2018	BUTERUS	SED 1708571 000 03
CHKD. 16.07.2018	WILHELM	CHANGE NO. SCALE
STAND. 16.07.2018	PRODASTSCHUK	1086956 15

DIMENSION  
 IN mm  
 EXCEPT AS  
 NOTED



OLTC OILTAP® M / VACUTAP® VM®, VMS®-C, VRC, VRE  
 ADDITIONAL SCREENING ON SELECTOR BASE - COARSE COS  
 M-SELECTOR SIZE B/C/D/DE

SERIAL NUMBER	
MATERIAL NUMBER 8939354E	SHEET 1 / 1

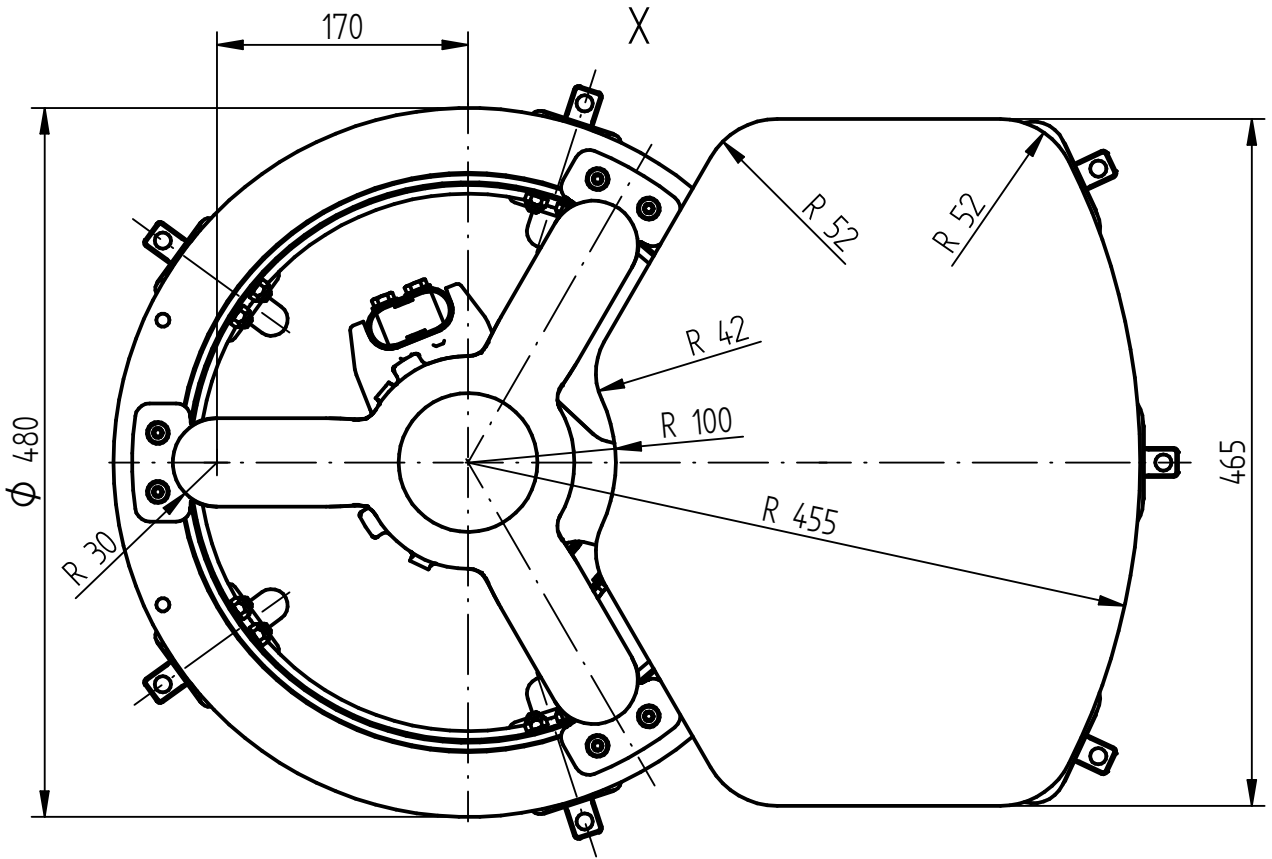
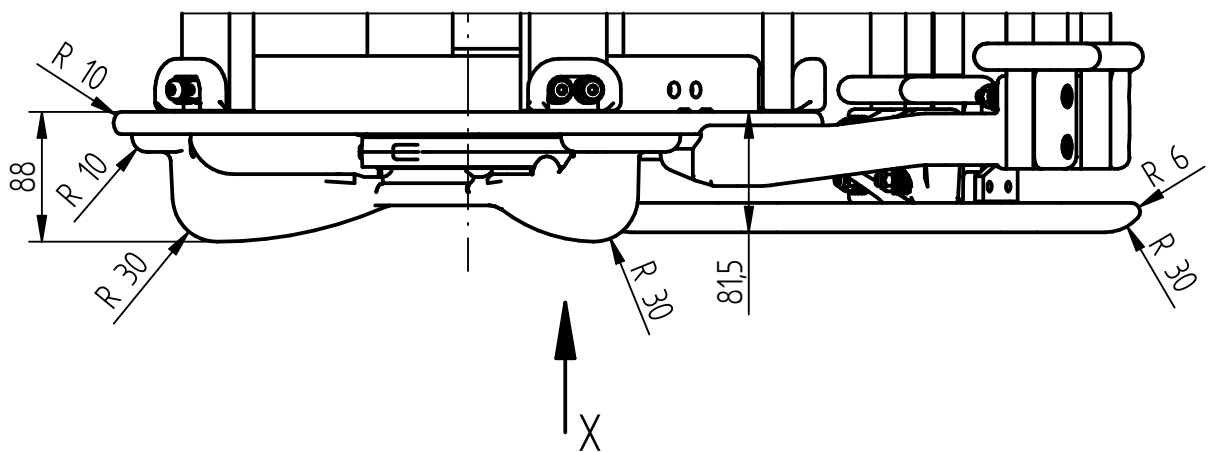

© MASCHINENFABRIK REINHAUSEN GMBH 2016  
 THE REPRODUCTION, DISTRIBUTION AND UTILIZATION OF THIS DOCUMENT AS WELL AS THE COMMUNICATION OF ITS CONTENTS TO OTHERS WITHOUT EXPRESS AUTHORIZATION IS PROHIBITED. OFFENDERS WILL BE HELD LIABLE FOR THE PAYMENT OF DAMAGES. ALL RIGHTS RESERVED IN THE EVENT OF THE GRANT OF A PATENT, UTILITY MODEL OR DESIGN.

### ARRANGEMENT OF CONTACT B

M | 802 / 803  
VM | 802 / 1002

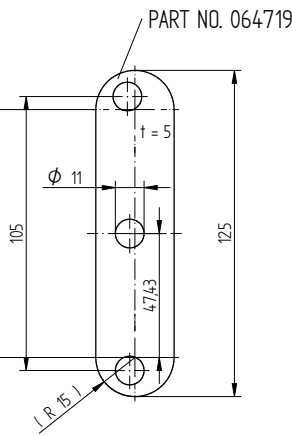

M | 1203 / 1503  
VM | 1203 / 1503

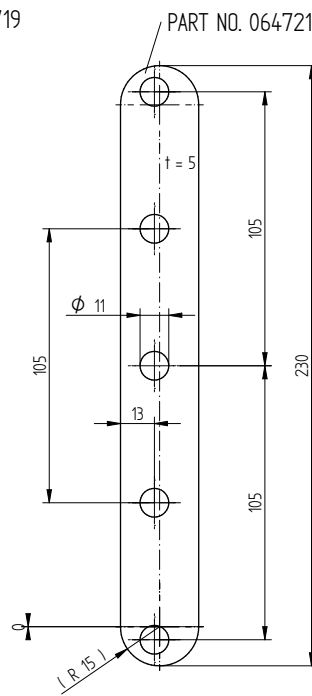

### ARRANGEMENT OF CONTACT A

M | 802 / 803 / 1203 / 1503  
VM | 802 / 1002 / 1203 / 1503

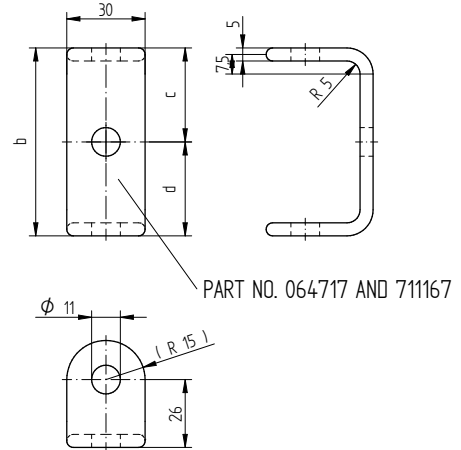

ARRANGEMENT OF CONTACT (see 890477:.)	PART NO.	DIMENSION b	DIMENSION c	DIMENSION d
A WITHOUT CONNECTING LEAD	064717	97	48,5	48,5
A WITH CONNECTING LEAD	711167	91	48,5	42,5

### INSTALLATION OF PARALLEL BRIDGES FOR ARRANGEMENT OF CONTACT A WITHOUT AND WITH CONNECTING LEAD FOR 3W CONNECTION

M | 802 / 803  
VM | 802 / 1002

WITHOUT CONNECTING LEAD

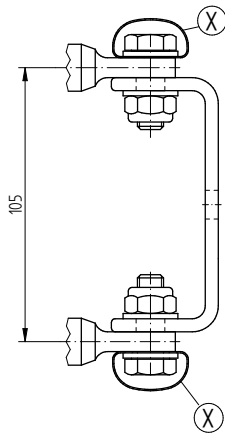

WITH CONNECTING LEAD

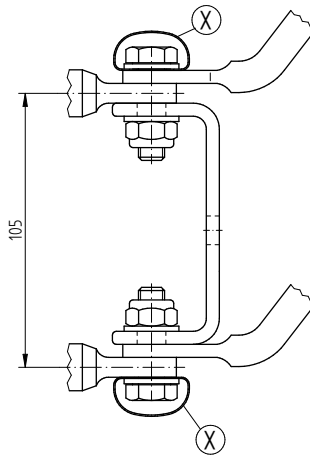

M | 1203 / 1503  
VM | 1203 / 1503

WITHOUT CONNECTING LEAD

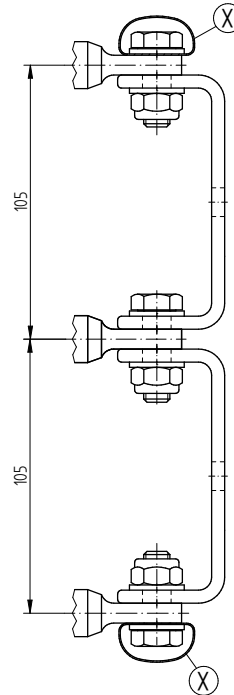

WITH CONNECTING LEAD

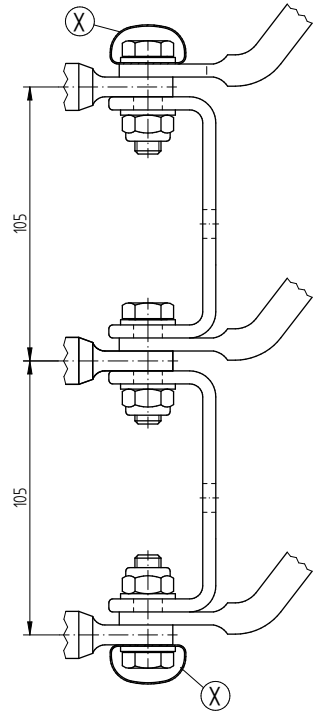

(X) ONLY FOR SELECTOR SIZE D AND DE

PLEASE NOTE: PARALLEL BRIDGES ARE NOT INCLUDED IN THE STANDARD DELIVERY.

DATE	NAME	DOCUMENT NO.
18.01.2016	RAEDLINGER	SED 1050471 000 05
25.02.2016	TKBIRKMAN	CHANGE NO.
25.02.2016	PRODASTSCHUK	1072100
		SCALE 1:1

DIMENSION IN mm EXCEPT AS NOTED



ON-LOAD TAP-CHANGER OILTAP® M | 802/803/1203/1503 AND VACUTAP® VM | 802/1002/1203/1503 - SELECTOR SIZE B/C/D/DE BRIDGES FOR PARALLEL CONNECTION OF SELECTOR CONN. CONT.

SERIAL NUMBER

MATERIAL NUMBER 8995984E SHEET 1/1

© MASCHINENFABRIK REINHAUSEN GMBH 2016  
 THE REPRODUCTION, DISTRIBUTION AND UTILIZATION OF THIS DOCUMENT AS WELL AS THE COMMUNICATION OF ITS CONTENTS TO OTHERS WITHOUT EXPRESS AUTHORIZATION IS PROHIBITED. OFFENDERS WILL BE HELD LIABLE FOR THE PAYMENT OF DAMAGES. ALL RIGHTS RESERVED IN THE EVENT OF THE GRANT OF A PATENT, UTILITY MODEL OR DESIGN.

DATE	18.10.2016	DOCUMENT NO.	SED 1050468 001 07
DFTR.	19.10.2016	NAME	CTETPRAKTIK2
CHKD.	20.10.2016	CHANGE NO.	HILTNER 1077668
STAND.		SCALE	1:10
		PRODASTSCHUK	

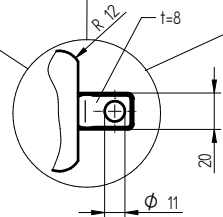
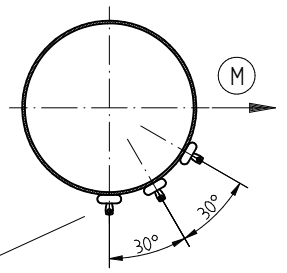
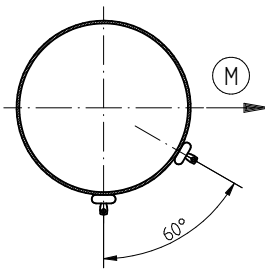
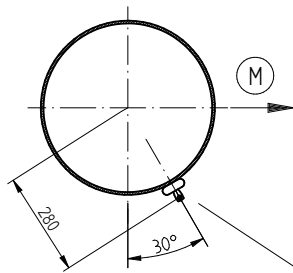
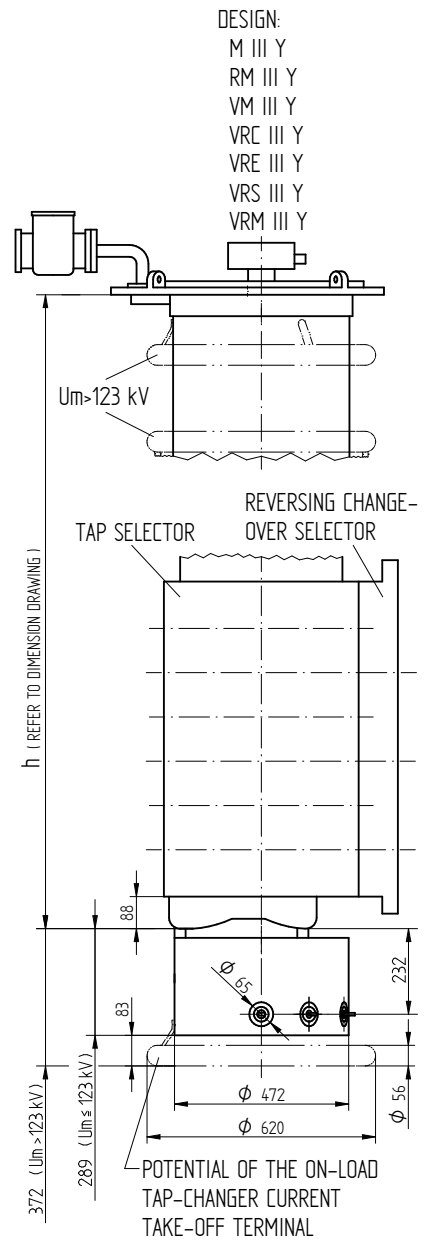
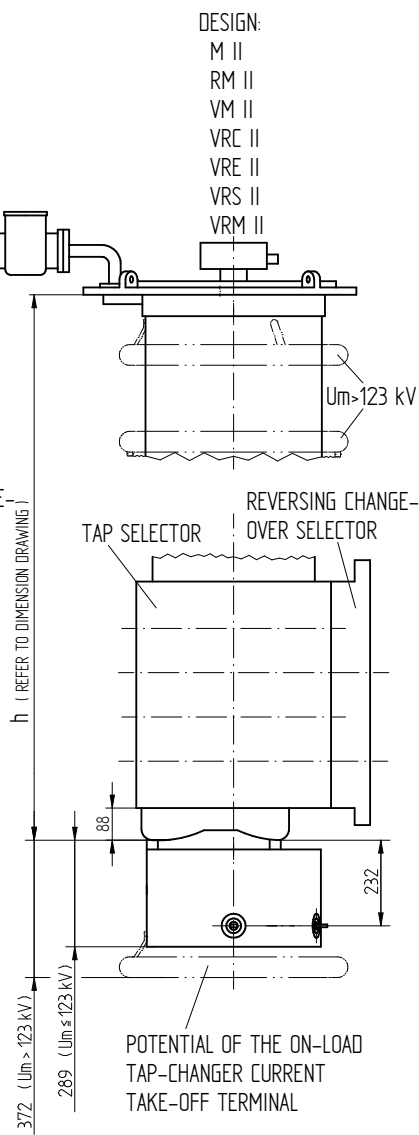
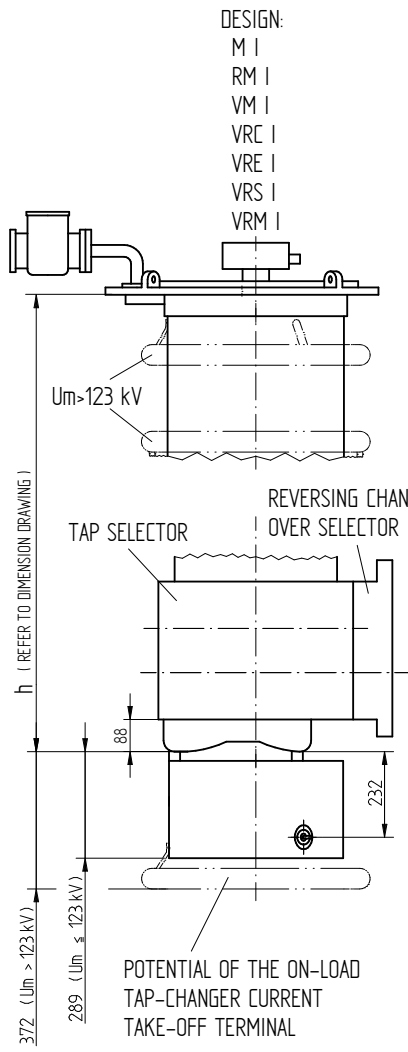

CONNECTION FOR EXTERNAL TIE-IN RESISTOR

(M) DRIVE SIDE OF SELECTOR

CONNECTING FROM TIE-IN SWITCH TO ON-LOAD TAP-CHANGER CURRENT TAKE-OFF TERMINAL IS CARRIED OUT BY MR THE DETAILED CONNECTION DIAGRAM IS BINDING FOR THE DESIGNATION OF THE CONNECTION CONTACTS AND PHASES

NOT APPLICABLE TO VM I 301, VM II 302 AND VM III 300 Y

DIMENSION  
 IN mm  
 EXCEPT AS  
 NOTED



ON-LOAD TAP-CHANGER OILTAP®M, RM / VACUTAP® VM, VR  
 M/RM/VM/VRC/VRE/VRS/VRM - REVERSING CHANGE-OVER SEL. - SIZE B/C/D/DE  
 POTENTIAL CONNECTION UNIT WITH TIE-IN SWITCH WITHOUT TIE-IN RESISTORS

SERIAL NUMBER

MATERIAL NUMBER  
 8988046E

SHEET  
 1/1



© MASCHINENFABRIK REINHAUSEN GMBH 2018  
 THE REPRODUCTION, DISTRIBUTION AND UTILIZATION OF THIS DOCUMENT AS WELL AS THE COMMUNICATION OF ITS CONTENTS TO OTHERS WITHOUT EXPRESS AUTHORIZATION IS PROHIBITED. OFFENDERS WILL BE HELD LIABLE FOR THE PAYMENT OF DAMAGES. ALL RIGHTS RESERVED IN THE EVENT OF A PATENT, UTILITY MODEL OR DESIGN.

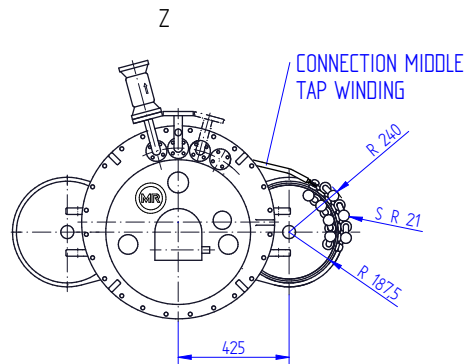
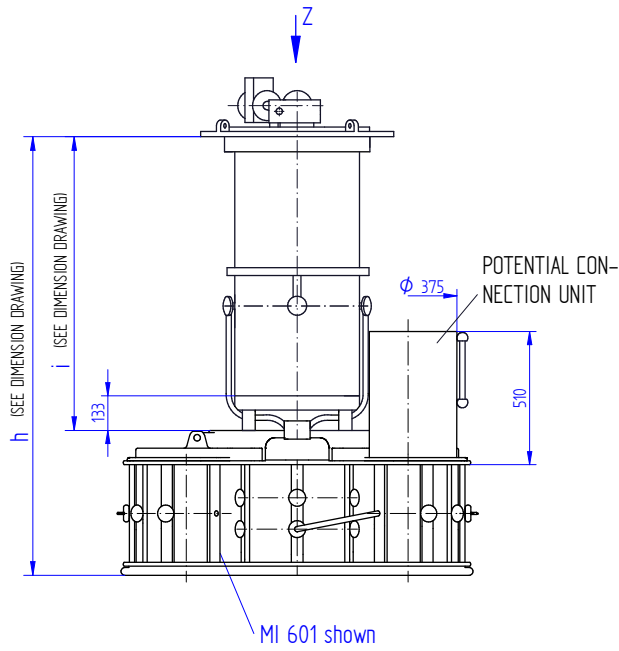

MAX. 7 RESISTOR ELEMENTS (AS SHOWN)

ARRANGEMENT OF SELECTOR CONTACTS,  
 2-5 COARSE TAP CONNECTIONS  
 (PLAN VIEW)

- x ) FOR 3 COARSE TAP CONNECTIONS
- x ) AND y ) FOR 4 COARSE TAP CONNECTIONS
- x ), y ) AND z ) FOR 5 COARSE TAP CONNECTIONS

CONNECTION MIDDLE TAP WINDING

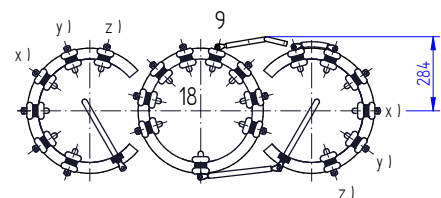
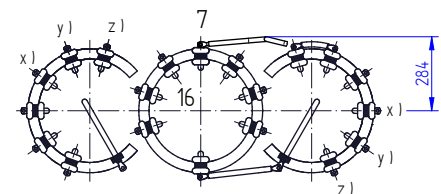
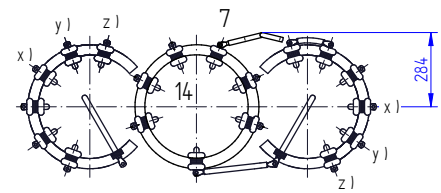
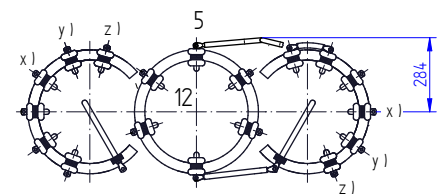
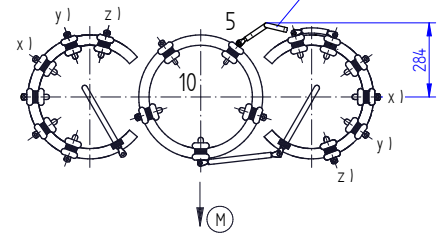

FOR BINDING DESIGNATIONS OF TERMINALS AND PHASES REFER TO THE CONNECTION DIAGRAM OF THE ON-LOAD TAP-CHANGER.

(M) DRIVE SIDE OF SELECTOR

DOCUMENT NO.	19.04.2018	NAME	RAEDLINGER
DFTR.	25.04.2018	CHANGE NO.	1087395
CHKD.	25.04.2018	SCALE	1:10
STAND.		PRODASTSCHUK	

DIMENSION  
 IN mm  
 EXCEPT AS  
 NOTED



ON-LOAD TAP-CHANGER OILTAP® M I AND VACUTAP® VM I, VRC I, VRS I, VRM I  
 WITH MULTIPLE COARSE CHANGE-OVER SELECTOR  
 MOUNTING OF TIE-IN RESISTORS - SELECTOR SIZE B/C/D

SERIAL NUMBER

MATERIAL NUMBER  
 7197337E

SHEET  
 1/1

© MASCHINENFABRIK REINHAUSEN GMBH 2016  
 THE REPRODUCTION, DISTRIBUTION AND UTILIZATION OF THIS DOCUMENT AS WELL AS THE COMMUNICATION OF ITS CONTENTS TO OTHERS WITHOUT EXPRESS AUTHORIZATION IS PROHIBITED. OFFENDERS WILL BE HELD LIABLE FOR THE PAYMENT OF DAMAGES. ALL RIGHTS RESERVED IN THE EVENT OF THE GRANT OF A PATENT, UTILITY MODEL OR DESIGN.

DATE	18.10.2016	DOCUMENT NO.	SED 1665234 000 05
CHD.	19.10.2016	NAME	CTETPRAKTIK2
STAND.	20.10.2016	CHANGE NO.	HILTNER
		SCALE	1:10
			1077668
			PRODASTSCHUK

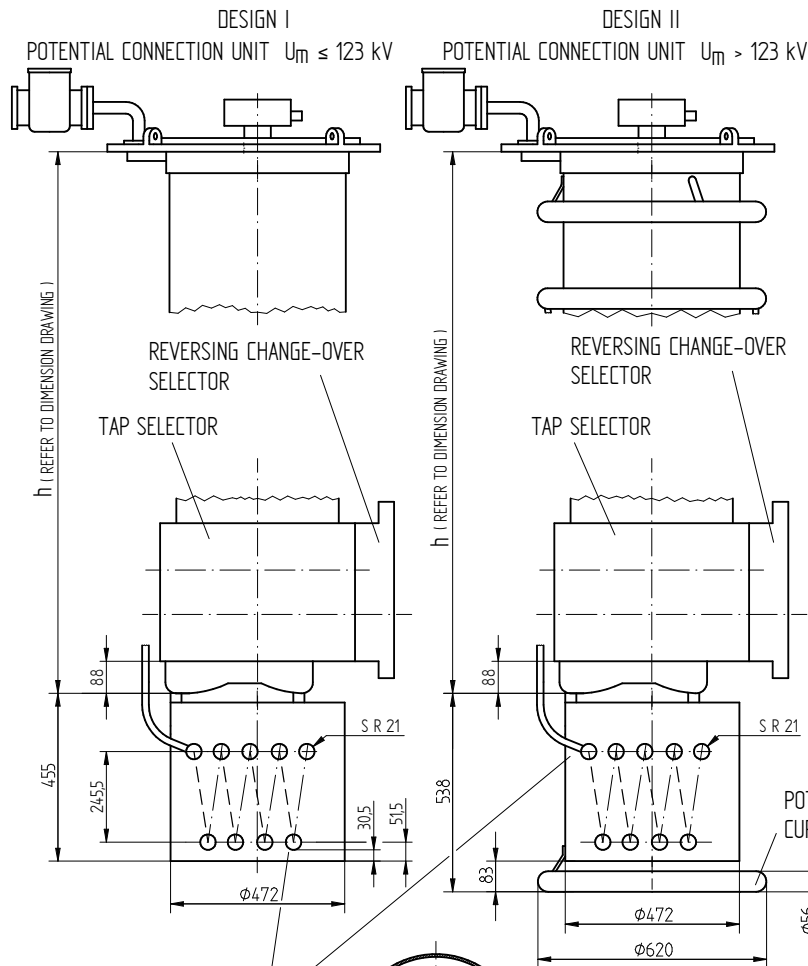

WITHOUT TIE-IN SWITCH  
 FOR MAX. 8 RESISTOR ELEMENTS  
 (AS SHOWN)

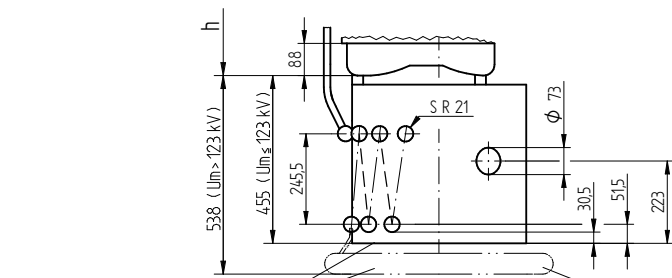
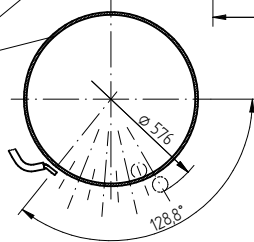

WITH TIE-IN SWITCH  
 FOR MAX. 6 RESISTOR ELEMENTS  
 (AS SHOWN)

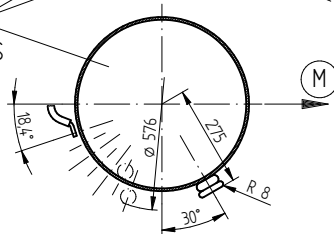

POTENTIAL OF THE MIDDLE  
 OF THE TAP WINDING

ARRANGEMENT OF LEADS  
 TIE-IN RESISTOR - SELECTOR  
 FOR CONTACT LOCATION REFER TO  
 RELEVANT DIMENSION DRAWING

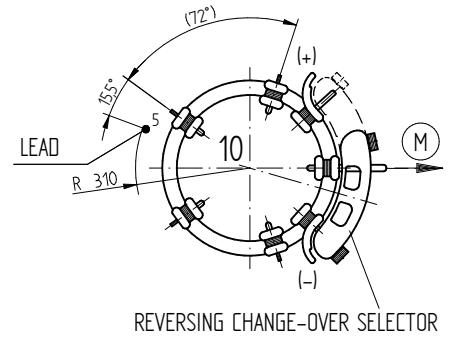

REVERSING CHANGE-OVER SELECTOR

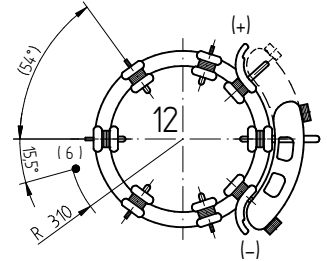

POTENTIAL OF THE ON-LOAD TAP-CHANGER  
 CURRENT TAKE-OFF TERMINAL

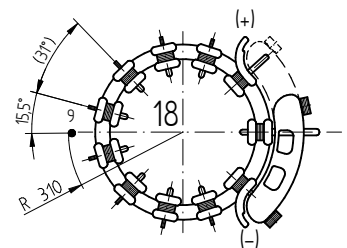
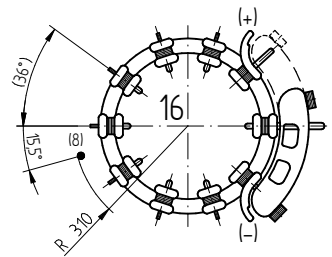
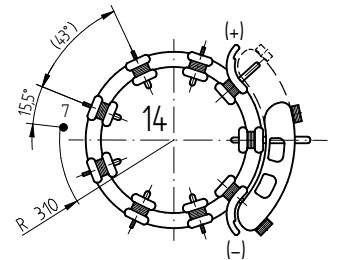

(M) DRIVE SIDE OF SELECTOR

THE DETAILED CONNECTION DIAGRAM IS BINDING FOR THE DESIGNATION OF THE CONNECTION CONTACTS AND PHASES  
 CONNECTIONS FROM THE TIE-IN RESISTOR TO THE SELECTOR AND TO THE ON-LOAD TAP-CHANGER CURRENT TAKE-OFF TERMINAL ARE CARRIED OUT BY MR

NOT APPLICABLE TO VM I 301

DIMENSION  
 IN mm  
 EXCEPT AS  
 NOTED



ON-LOAD TAP-CHANGER OILTAP®M, RM / VACUTAP® VM, VR  
 M/RM/VM/VRC/VRE/VRS/VRM I - REVERS. CHANGE-OVER SEL. - SIZE B/C/D/DE  
 TIE-IN RESISTORS WITH/WITHOUT TIE-IN SWITCH

SERIAL NUMBER

MATERIAL NUMBER  
 8986905E

SHEET  
 1/1

© MASCHINENFABRIK REINHAUSEN GMBH 2016  
 THE REPRODUCTION, DISTRIBUTION AND UTILIZATION OF THIS DOCUMENT AS WELL AS THE COMMUNICATION OF ITS CONTENTS TO OTHERS WITHOUT EXPRESS AUTHORIZATION IS PROHIBITED. OFFENDERS WILL BE HELD LIABLE FOR THE PAYMENT OF DAMAGES. ALL RIGHTS RESERVED IN THE EVENT OF THE GRANT OF A PATENT, UTILITY MODEL OR DESIGN.

DATE	20.10.2016	DOCUMENT NO.	SED 1665189 000 05
DFTR.	20.10.2016	NAME	CTETPRAKTIK2
CHKD.	20.10.2016	CHANGE NO.	HILTNER
STAND.	20.10.2016	SCALE	1:10
		1077668	PRODASTSCHUK

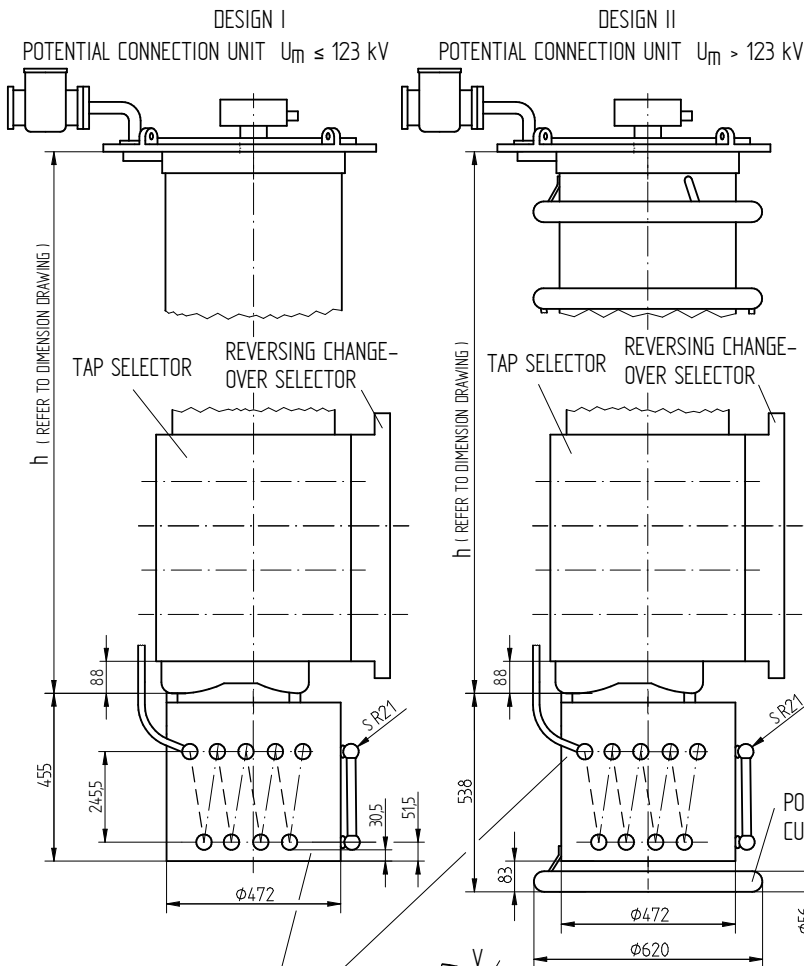

WITHOUT TIE-IN SWITCH  
 FOR MAX. 8 RESISTOR  
 ELEMENTS PER PHASE  
 ( AS SHOWN )

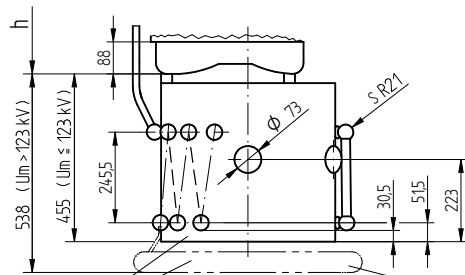
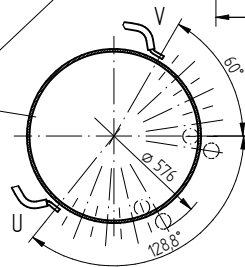

WITH TIE-IN SWITCH  
 FOR MAX. 6 RESISTOR  
 ELEMENTS PER PHASE  
 ( AS SHOWN )

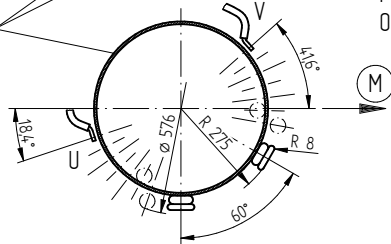

(M) DRIVE SIDE OF SELECTOR

THE DETAILED CONNECTION DIAGRAM IS BINDING FOR THE DESIGNATION OF THE CONNECTION CONTACTS AND PHASES  
 CONNECTIONS FROM THE TIE-IN RESISTOR TO THE SELECTOR AND TO THE ON-LOAD TAP-CHANGER CURRENT TAKE-OFF TERMINAL ARE CARRIED OUT BY MR

NOT APPLICABLE TO VM II 302

ARRANGEMENT OF LEADS  
 TIE-IN RESISTOR - PHASE  
 FOR CONTACT LOCATION REFER TO  
 RELEVANT DIMENSION DRAWING

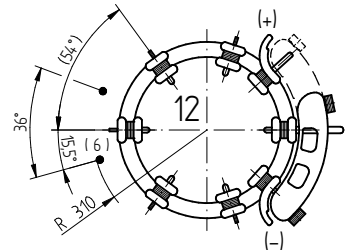
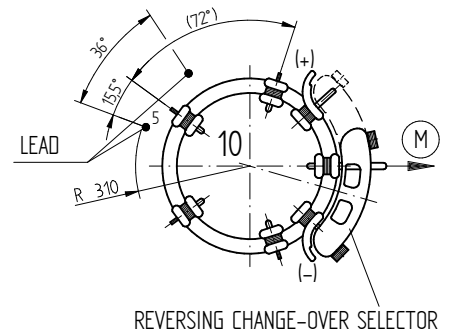

POTENTIAL OF THE ON-LOAD TAP-CHANGER  
 CURRENT TAKE-OFF TERMINAL

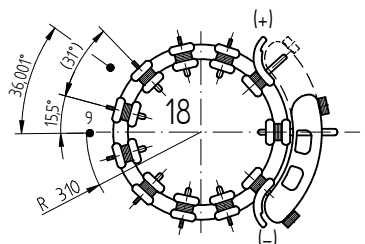
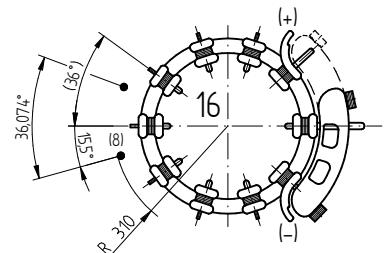
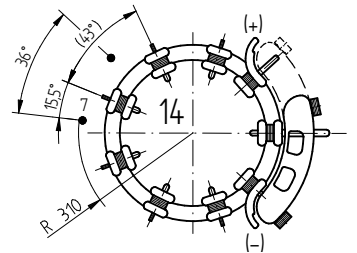

DIMENSION  
 IN mm  
 EXCEPT AS  
 NOTED



ON-LOAD TAP-CHANGER OILTAP®M, RM / VACUTAP® VM, VR  
 M/RM/VM/VRC/VRE/VRS/VRM II- REVERS. CHANGE-OVER SEL- SIZE B/C/D/DE  
 TIE-IN RESISTORS WITH/WITHOUT TIE-IN SWITCH

SERIAL NUMBER

MATERIAL NUMBER  
 8986915E

SHEET  
 1/1

© MASCHINENFABRIK REINHAUSEN GMBH 2018  
 THE REPRODUCTION, DISTRIBUTION AND UTILIZATION OF THIS DOCUMENT AS WELL AS THE COMMUNICATION OF ITS CONTENTS TO OTHERS WITHOUT EXPRESS AUTHORIZATION IS PROHIBITED. OFFENDERS WILL BE HELD LIABLE FOR THE PAYMENT OF DAMAGES. ALL RIGHTS RESERVED IN THE EVENT OF THE GRANT OF A PATENT, UTILITY MODEL OR DESIGN.

DATE	DOCUMENT NO.	NAME	SCALE
12.07.2018	SED 1665139 000 06	BUTERUS	1:10
16.07.2018	CHANGE NO.	WILHELM	
16.07.2018	1086956	PRODASTSCHUK	

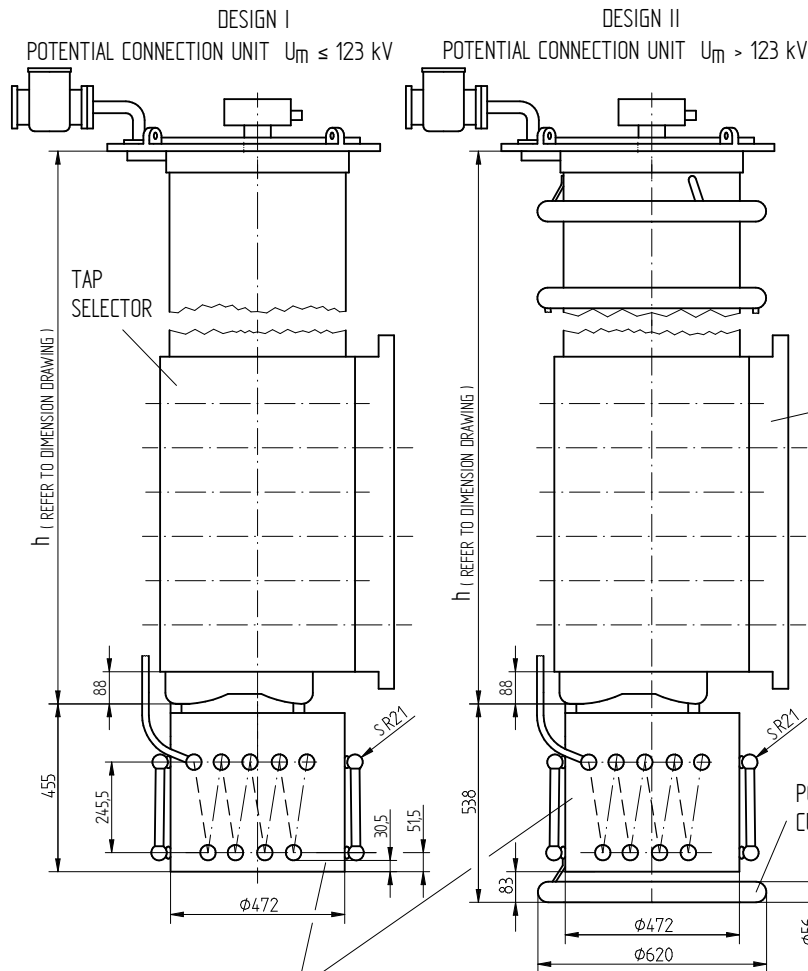

WITHOUT TIE-IN SWITCH  
 FOR MAX. 8 RESISTOR  
 ELEMENTS PER PHASE  
 (AS SHOWN)

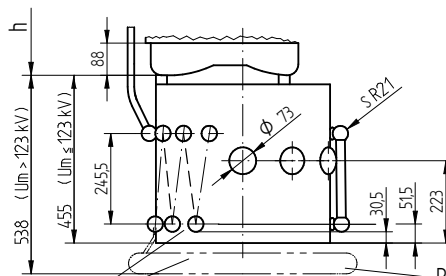
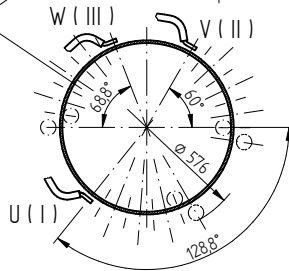

WITH TIE-IN SWITCH  
 FOR MAX. 6 RESISTOR  
 ELEMENTS PER PHASE  
 (AS SHOWN)

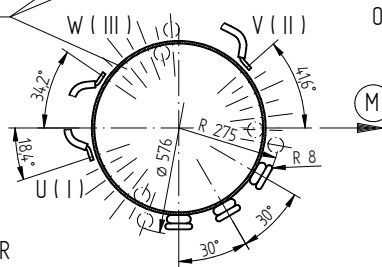

(M) DRIVE SIDE OF SELECTOR

THE DETAILED CONNECTION DIAGRAM IS BINDING FOR THE DESIGNATION OF THE CONNECTION CONTACTS AND PHASES  
 CONNECTIONS FROM THE TIE-IN RESISTOR TO THE SELECTOR AND TO THE ON-LOAD TAP-CHANGER CURRENT TAKE-OFF TERMINAL ARE CARRIED OUT BY MR

NOT APPLICABLE TO VMS III 400 Y - B

ARRANGEMENT OF LEADS  
 TIE-IN RESISTOR - PHASE  
 FOR CONTACT LOCATION REFER TO  
 RELEVANT DIMENSION DRAWING

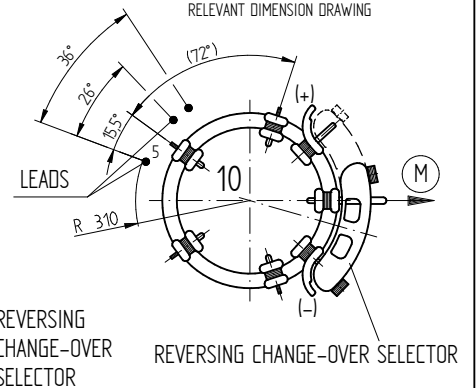

REVERSING  
 CHANGE-OVER  
 SELECTOR

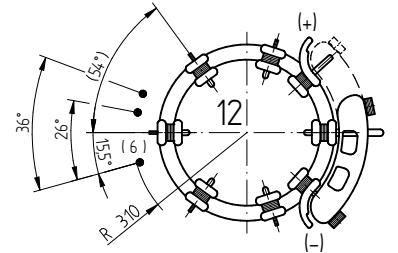

POTENTIAL OF THE ON-LOAD TAP-CHANGER  
 CURRENT TAKE-OFF TERMINAL

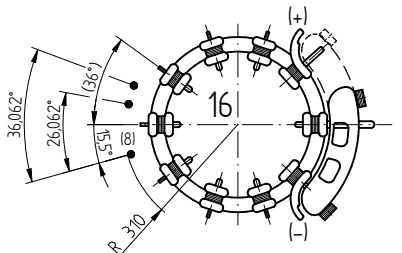
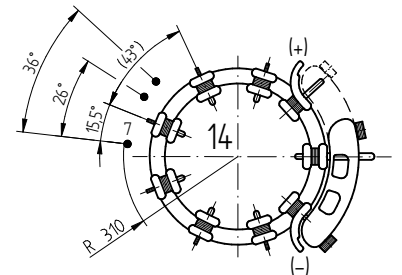

POTENTIAL OF THE MIDDLE  
 OF THE TAP WINDING

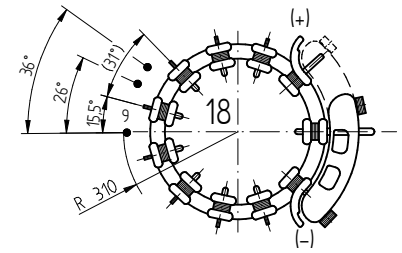

DIMENSION  
 IN mm  
 EXCEPT AS  
 NOTED



OLTC OILTAP® M, RM / VACUTAP® VM®, VMS®-C, VR®  
 M/RM/VM/VMS/VRC/VRE/VRS/VRM III Y - REV. COS - M-SEL. SIZE B/C/D/DE  
 TIE-IN RESISTORS WITH / WITHOUT TIE-IN SWITCH

SERIAL NUMBER

MATERIAL NUMBER  
 8986926E

SHEET  
 1/1

© MASCHINENFABRIK REINHAUSEN GMBH 2018  
 THE REPRODUCTION, DISTRIBUTION AND UTILIZATION OF THIS DOCUMENT AS WELL AS THE COMMUNICATION OF ITS CONTENTS TO OTHERS WITHOUT EXPRESS AUTHORIZATION IS PROHIBITED. OFFENDERS WILL BE HELD LIABLE FOR THE PAYMENT OF DAMAGES. ALL RIGHTS RESERVED IN THE EVENT OF A PATENT, UTILITY MODEL OR DESIGN.

DATE	NAME	DOCUMENT NO.
DFTR. 11.07.2018	BUTERUS	SED 6181604-001 00
CHKD. 16.07.2018	WILHELM	SCALE
STAND. 16.07.2018	PRODASTSCHUK	1086956
		18

SELECTOR WITHOUT CHANGE-OVER SELECTOR

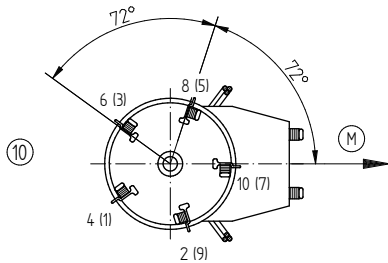

SELECTOR WITH REVERSING CHANGE-OVER SELECTOR

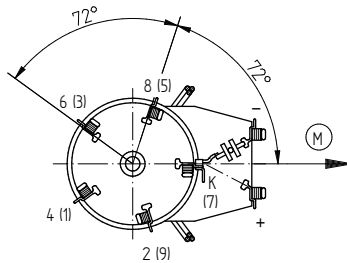

SELECTOR WITH COARSE CHANGE-OVER SELECTOR

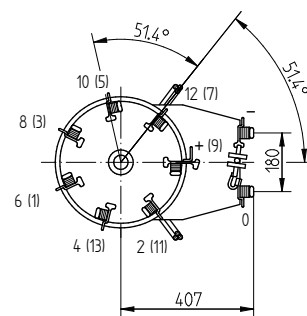
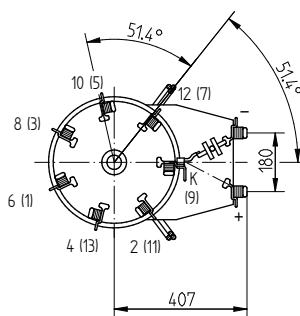
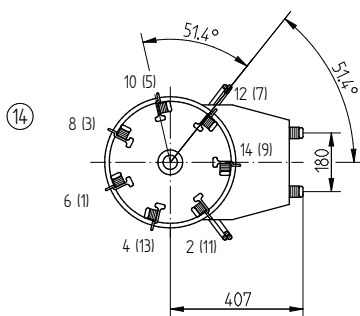
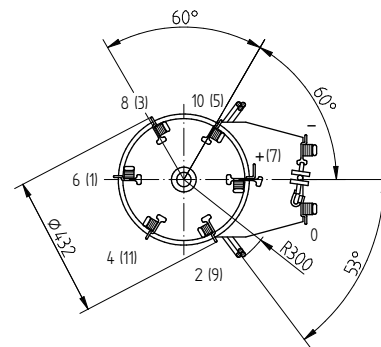
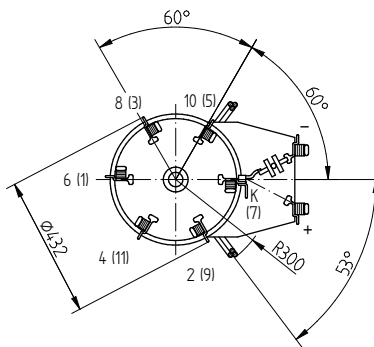
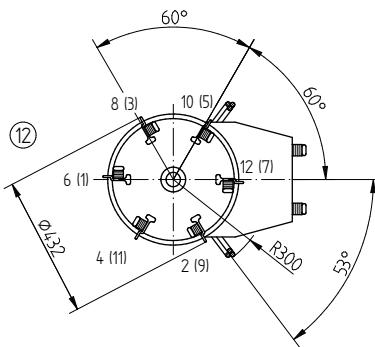
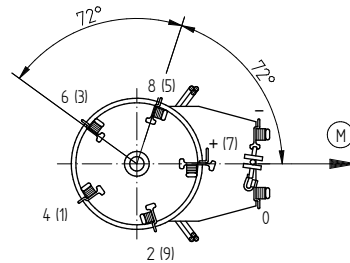

DESIGNATION OF SELECTOR TERMINALS  
 E. G.: 4 UPPER CONTACT PLANE  
 (13) LOWER CONTACT PLANE

(M) DRIVE SIDE OF SELECTOR  
 (10) (12) (14) SELECTOR PITCH

FOR BINDING DESIGNATIONS OF TERMINALS AND PHASES REFER TO THE CONNECTION DIAGRAM OF THE ON-LOAD TAP-CHANGER.

DIMENSION IN mm EXCEPT AS NOTED



ON-LOAD TAP-CHANGER VACUTAP® VMS®  
 ARRANGEMENT OF CONTACTS AT SELECTOR  
 SELECTOR SIZE B

SERIAL NUMBER

MATERIAL NUMBER  
101170250E

SHEET  
1/1

© MASCHINENFABRIK REINHAUSEN GMBH 2018  
 THE REPRODUCTION, DISTRIBUTION AND UTILIZATION OF THIS DOCUMENT AS WELL AS THE COMMUNICATION OF ITS CONTENTS TO OTHERS WITHOUT EXPRESS AUTHORIZATION IS PROHIBITED. OFFENDERS WILL BE HELD LIABLE FOR THE PAYMENT OF DAMAGES. ALL RIGHTS RESERVED IN THE EVENT OF THE GRANT OF A PATENT, UTILITY MODEL OR DESIGN.

DFTR.	DATE	NAME	DOCUMENT NO.
CHKD.	11.07.2018	BUTERUS	SED 6181620 001 00
STAND.	16.07.2018	WILHELM	SCALE
	16.07.2018	PRODASTSCHUK	1086956

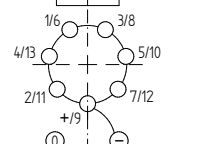
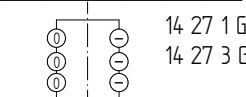
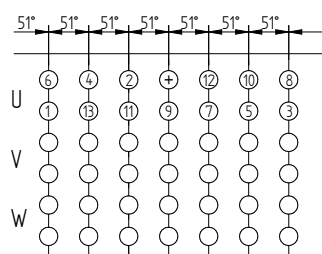
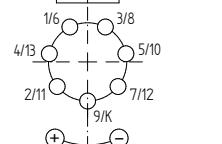
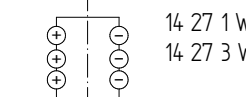
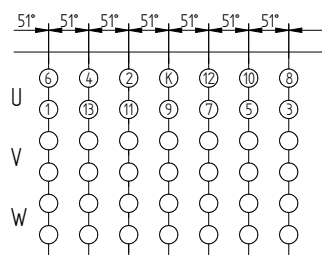
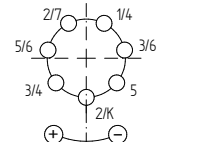
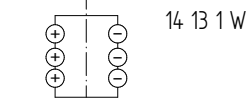
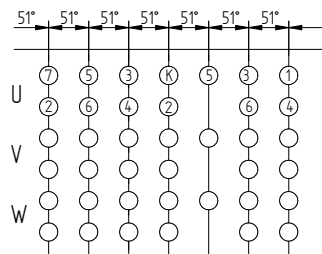
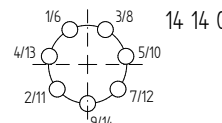
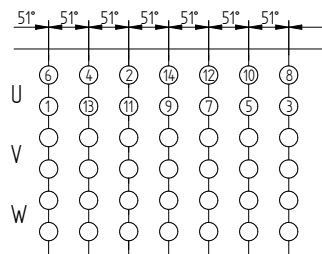
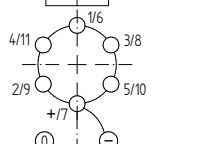
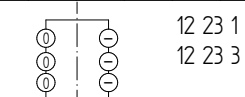
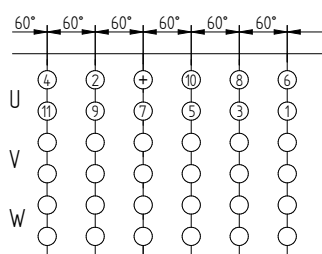
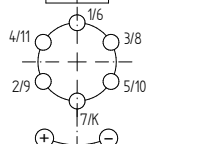
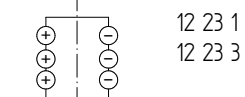
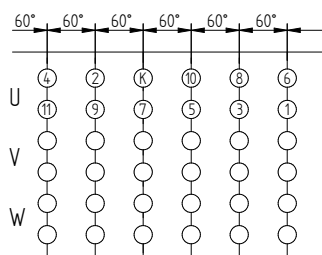
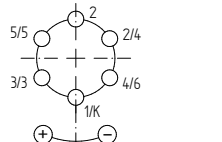
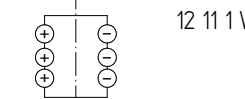
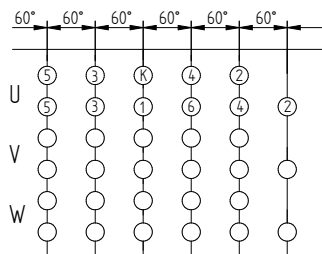
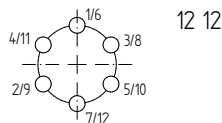
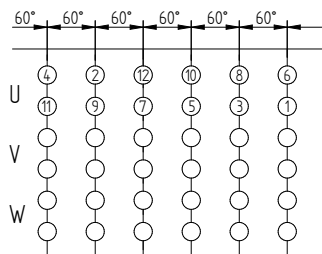
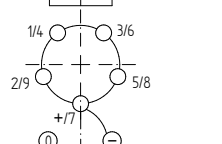
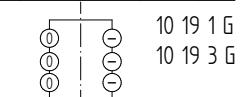
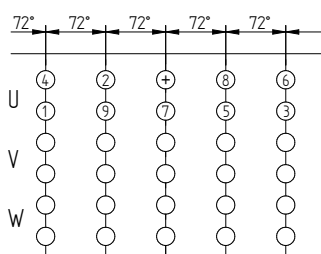
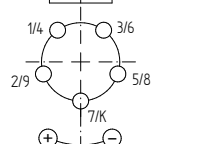
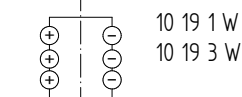
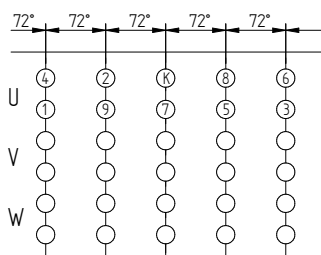
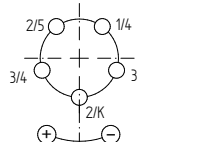
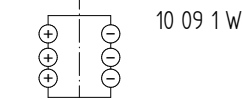
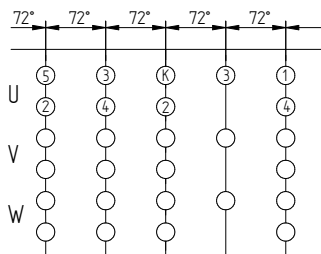
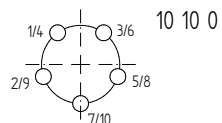
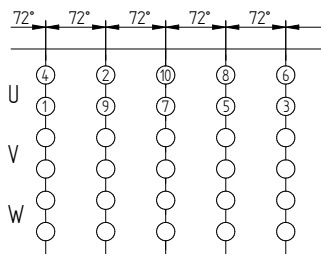

DIMENSION  
IN mm  
EXCEPT AS  
NOTED



ON-LOAD TAP-CHANGER VACUTAP® VMS®  
CONTACT ARRANGEMENT ON SELECTOR  
SELECTOR SIZE B

SERIAL NUMBER

MATERIAL NUMBER  
101170290E

SHEET  
1/1

© MASCHINENFABRIK REINHOLD GMBH 2018  
 THE REPRODUCTION, DISTRIBUTION AND UTILIZATION OF THIS DOCUMENT AS WELL AS THE COMMUNICATION OF ITS CONTENTS TO OTHERS WITHOUT EXPRESS AUTHORIZATION IS PROHIBITED. OFFENDERS WILL BE HELD LIABLE FOR THE PAYMENT OF DAMAGES. ALL RIGHTS RESERVED IN THE EVENT OF THE GRANT OF A PATENT, UTILITY MODEL OR DESIGN.

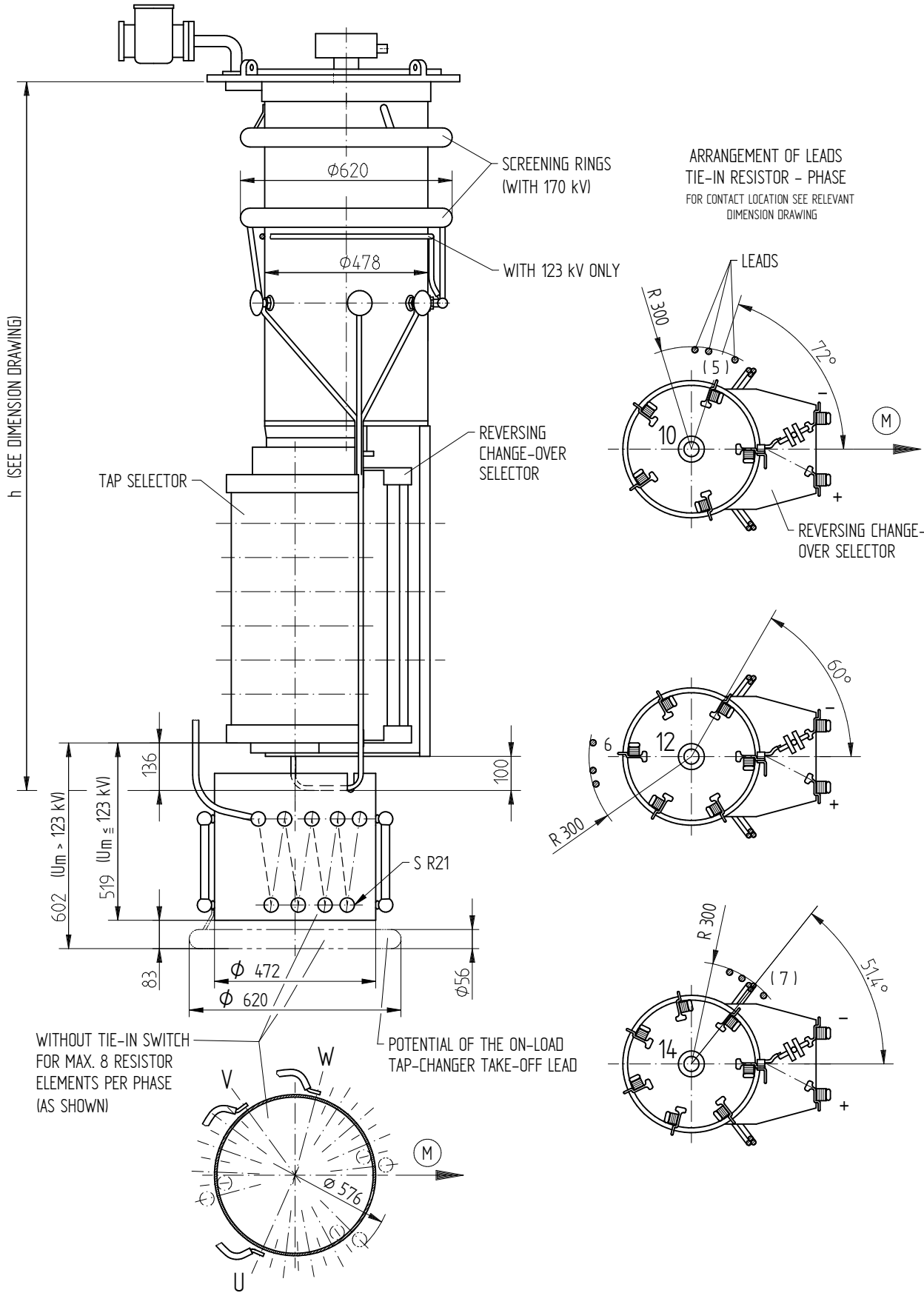

(M) - DRIVE SIDE OF SELECTOR

THE CONNECTION DIAGRAM OF THE ON-LOAD TAP-CHANGER IS BINDING FOR THE DESIGNATION OF THE TERMINALS AND PHASES.

DATE	NAME	DOCUMENT NO.
11.07.2018	BUTERUS	SED 6011874 001 00
CHKD. 16.07.2018	WILHELM	CHANGE NO.
STAND. 16.07.2018	PRODASTSCHUK	1086956
		SCALE 1:8

DIMENSION  
 IN mm  
 EXCEPT AS  
 NOTED



ON-LOAD TAP-CHANGER VACUTAP® VMS®  
 VMSIII400Y - B - TIE-IN RESISTORS WITHOUT TIE-IN SWITCH  
 DIMENSION DRAWING

SERIAL NUMBER

MATERIAL NUMBER  
 101165630E

SHEET  
 1/1

© MASCHINENFABRIK REINHAUSEN GMBH 2016  
 THE REPRODUCTION, DISTRIBUTION AND UTILIZATION OF THIS DOCUMENT AS WELL AS THE COMMUNICATION OF ITS CONTENTS TO OTHERS WITHOUT EXPRESS AUTHORIZATION IS PROHIBITED. OFFENDERS WILL BE HELD LIABLE FOR THE PAYMENT OF DAMAGES. ALL RIGHTS RESERVED IN THE EVENT OF THE GRANT OF A PATENT, UTILITY MODEL OR DESIGN.

SELECTOR WITHOUT CHANGE-OVER SELECTOR

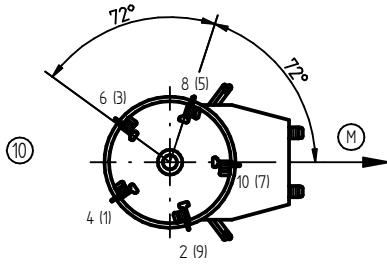

SELECTOR WITH REVERSING CHANGE-OVER SELECTOR

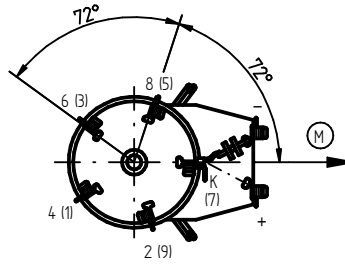

SELECTOR WITH COARSE CHANGE-OVER SELECTOR

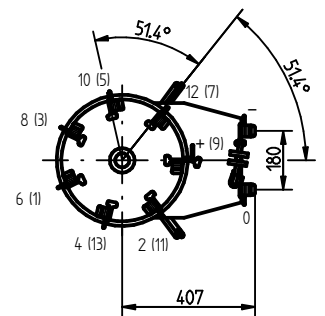
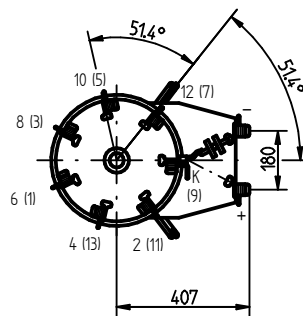
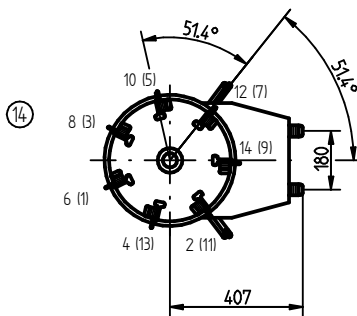
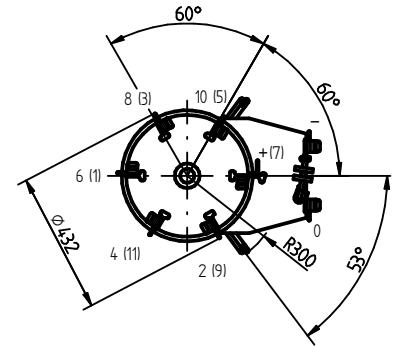
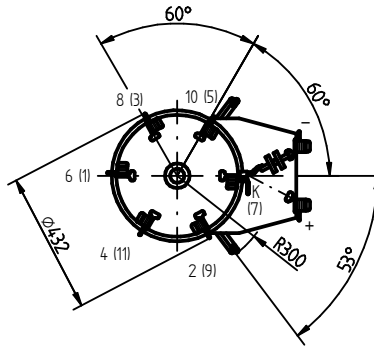
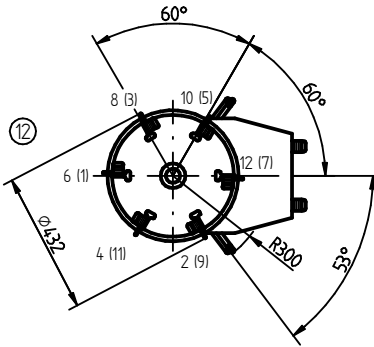
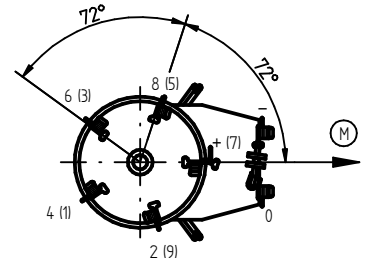

DESIGNATION OF SELECTOR TERMINALS  
 E. G.: 4 UPPER CONTACT PLANE  
 (13) LOWER CONTACT PLANE

(M) DRIVE SIDE OF SELECTOR  
 (10) (12) (14) SELECTOR PITCH

FOR BINDING DESIGNATIONS OF TERMINALS AND PHASES REFER TO THE CONNECTION DIAGRAM OF THE ON-LOAD TAP-CHANGER.

DATE	NAME	DOCUMENT NO.
26.01.2016	RAEDLINGER	SED 1050454-001 02
CHKD. 25.02.2016	TKBIRKMAN	SCALE
STAND 25.02.2016	PRODASTSCHUK	CHANGE NO. 1072100
		18

DIMENSION  
 IN mm  
 EXCEPT AS  
 NOTED



ON-LOAD TAP-CHANGER OILTAP® MS / VACUTAP® VM 300  
 ARRANGEMENT OF CONTACTS AT SELECTOR  
 SELECTOR SIZE B

SERIAL NUMBER

MATERIAL NUMBER  
 8980414E

SHEET  
 1/1



© MASCHINENFABRIK REINHAUSEN GMBH 2016  
 THE REPRODUCTION, DISTRIBUTION AND UTILIZATION OF THIS DOCUMENT AS WELL AS THE COMMUNICATION OF ITS CONTENTS WITHOUT EXPRESS AUTHORIZATION IS PROHIBITED. OFFENDERS WILL BE HELD LIABLE FOR THE PAYMENT OF DAMAGES. ALL RIGHTS RESERVED IN THE EVENT OF THE GRANT OF A PATENT, UTILITY MODEL OR DESIGN.

DATE	NAME	DOCUMENT NO.
26.01.2016	RAEDLINGER	SED 2617011 001 01
25.02.2016	TKBIRKMANN	SCALE
25.02.2016	PRODASTSCHUK	CHANGE NO.
		1072100

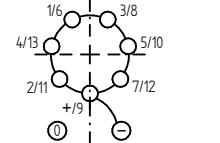
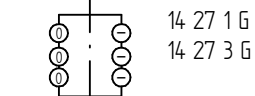
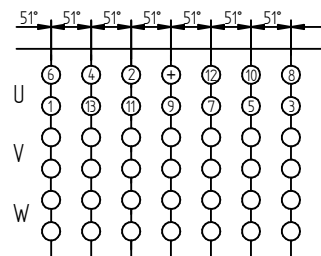
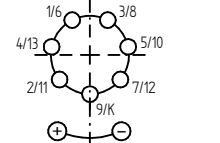
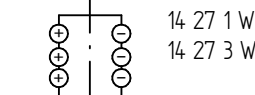
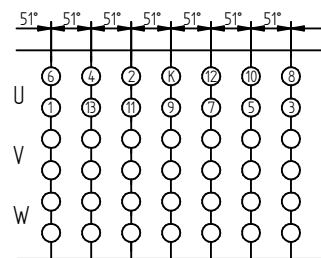
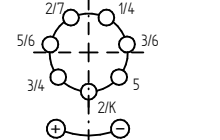
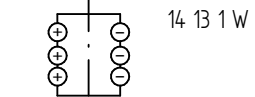
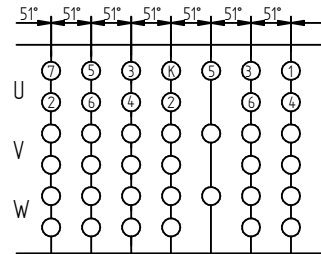
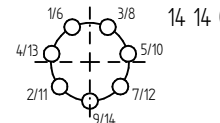
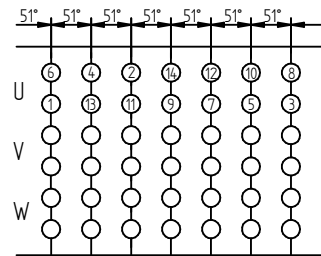
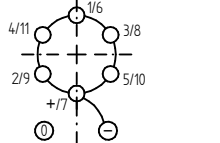
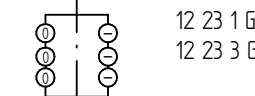
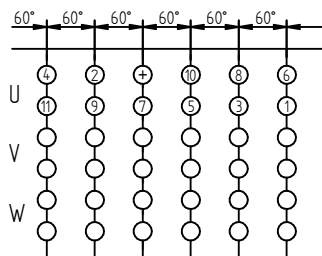
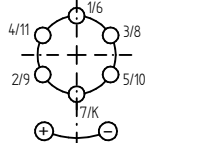
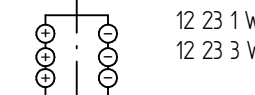
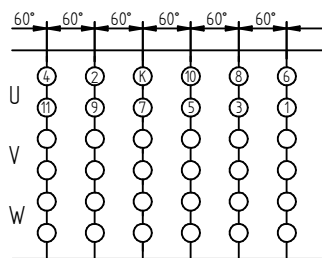
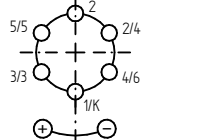
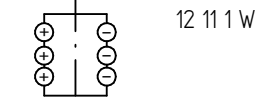
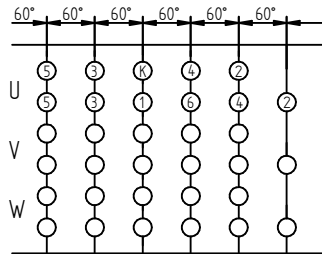
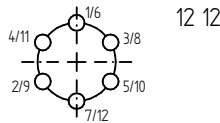
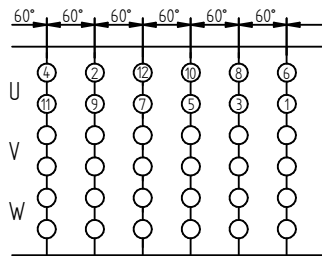
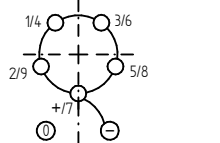
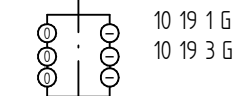
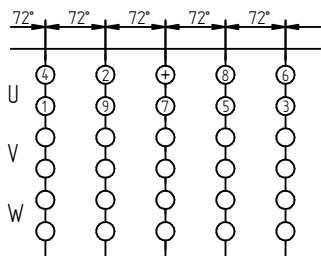
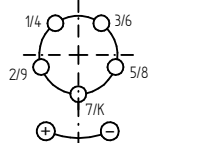
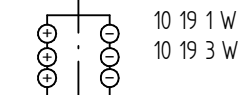
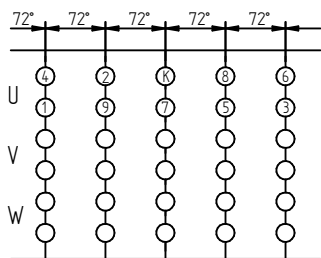
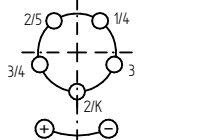
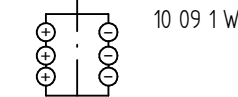
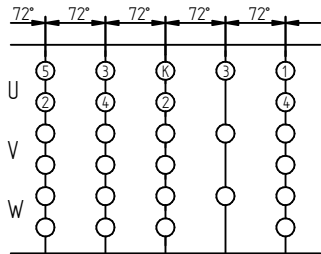
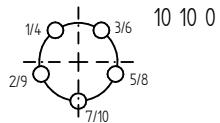
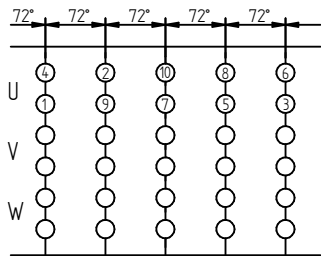

DIMENSION  
IN mm  
EXCEPT AS  
NOTED



ON-LOAD TAP-CHANGER OILTAP® MS / VACUTAP® VM 300  
CONTACT ARRANGEMENT ON SELECTOR FOR SELECTOR SIZE B

SERIAL NUMBER

MATERIAL NUMBER  
8911145E

SHEET  
1/1

© MASCHINENFABRIK REINHAUSEN GMBH 2016  
 THE REPRODUCTION, DISTRIBUTION AND UTILIZATION OF THIS DOCUMENT AS WELL AS THE COMMUNICATION OF ITS CONTENTS WITHOUT EXPRESS AUTHORIZATION IS PROHIBITED. OFFENDERS WILL BE HELD LIABLE FOR THE PAYMENT OF DAMAGES. ALL RIGHTS RESERVED IN THE EVENT OF THE GRANT OF A PATENT, UTILITY MODEL OR DESIGN.

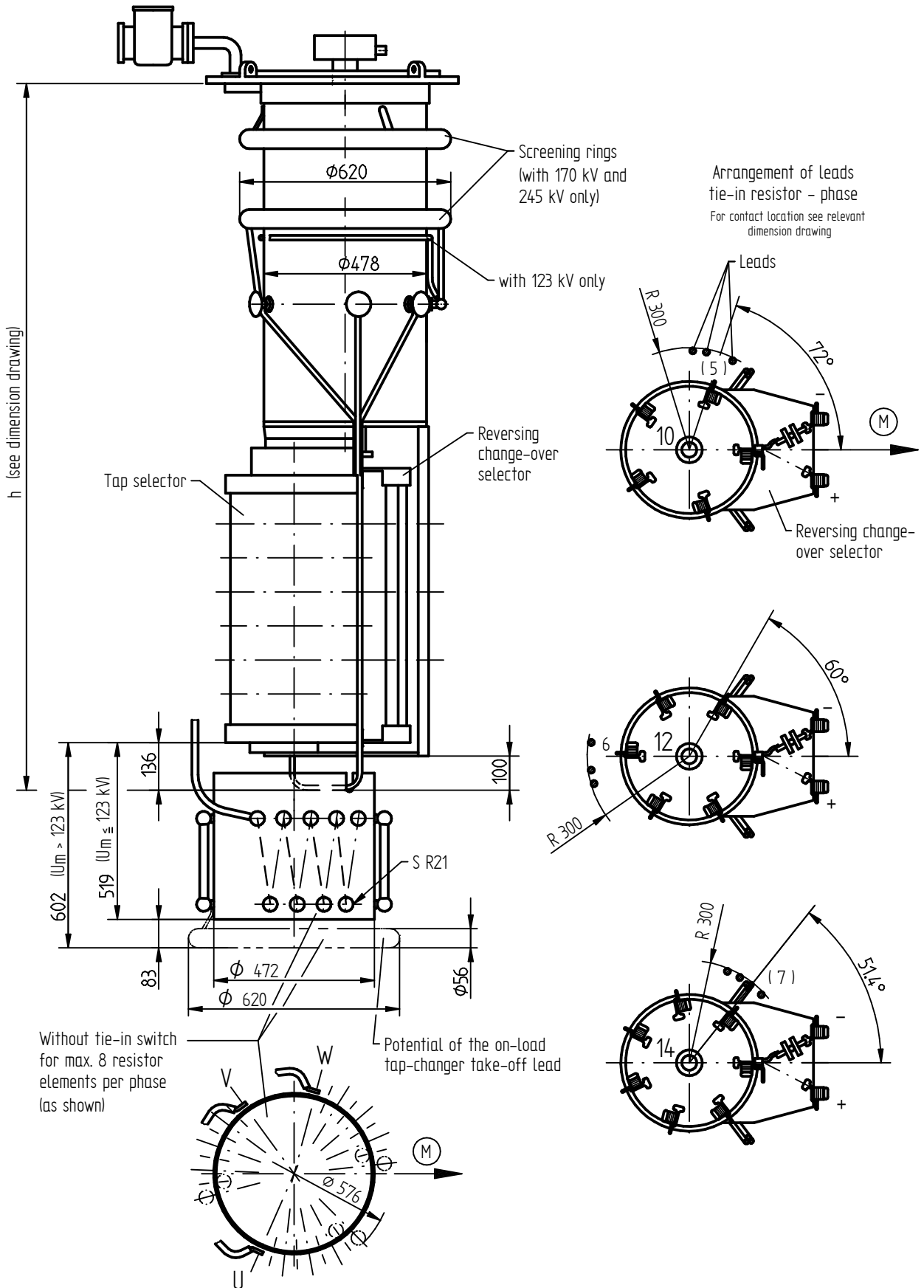

(M) - Drive side of selector

The connection diagram of the on-load tap-changer is binding for the designation of the terminals and phases.

DATE	NAME	DOCUMENT NO.
23.03.2016	RAEDLINGER	SED 1050467 001 04
CHKD. 11.04.2016	MENZELS	CHANGE NO.
STAND. 11.04.2016	PRODASTSCHUK	1073378
		SCALE
		1:8

DIMENSION  
IN mm  
EXCEPT AS  
NOTED



ON-LOAD TAP-CHANGER OILTAP® MS AND VACUTAP® VM®  
MS III / VM III 300 - SELECTOR SIZE B  
TIE-IN RESISTORS WITHOUT TIE-IN SWITCH

SERIAL NUMBER

MATERIAL NUMBER  
8986954E

SHEET  
1/1

© MASCHINENFABRIK REINHAUSEN GMBH 2016  
 THE REPRODUCTION, DISTRIBUTION AND UTILIZATION OF THIS DOCUMENT AS WELL AS THE COMMUNICATION OF ITS CONTENTS TO OTHERS WITHOUT EXPRESS AUTHORIZATION IS PROHIBITED. OFFENDERS WILL BE HELD LIABLE FOR THE PAYMENT OF DAMAGES. ALL RIGHTS RESERVED IN THE EVENT OF THE GRANT OF A PATENT, UTILITY MODEL OR DESIGN.

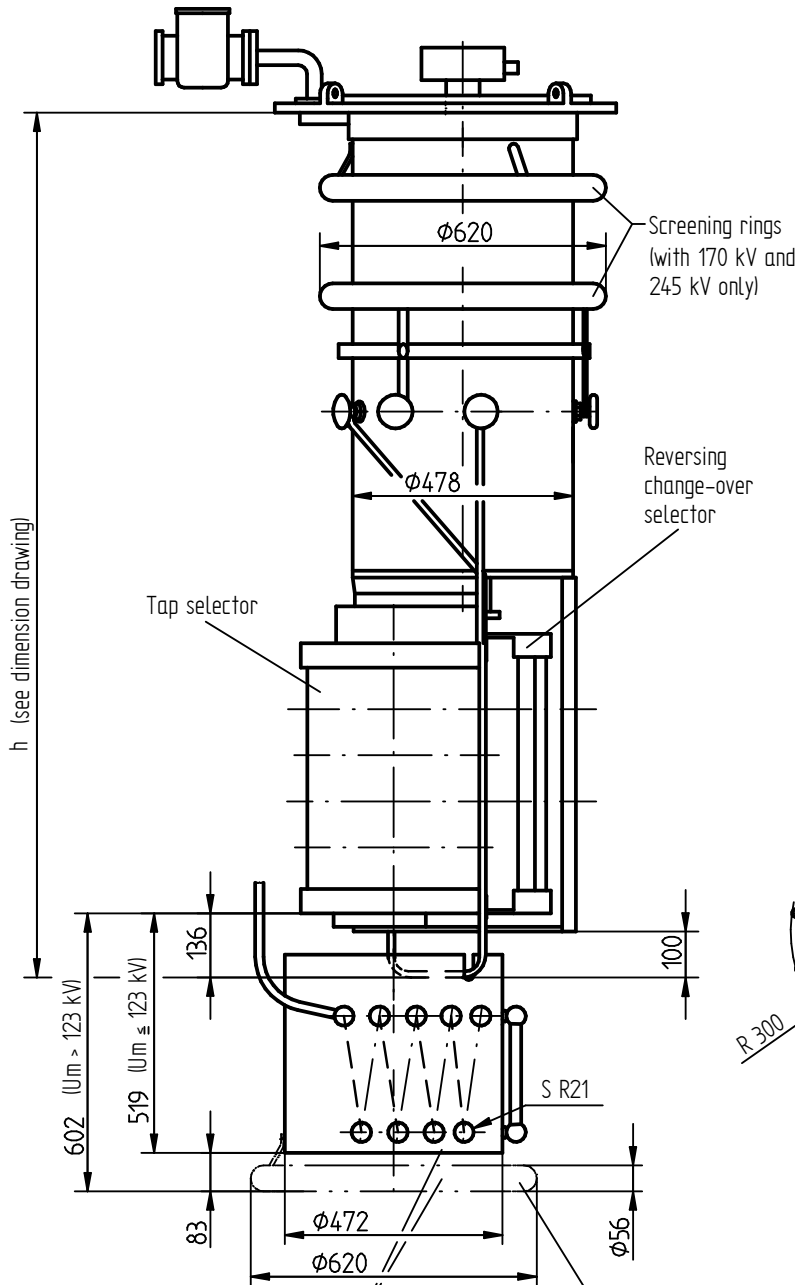

Arrangement of leads tie-in resistor - phase  
 For contact location see relevant dimension drawing

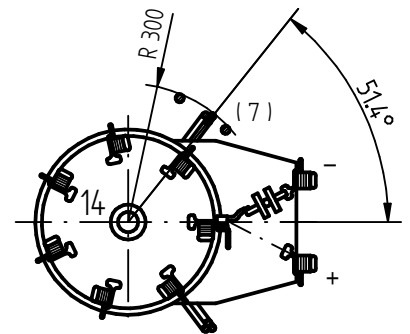
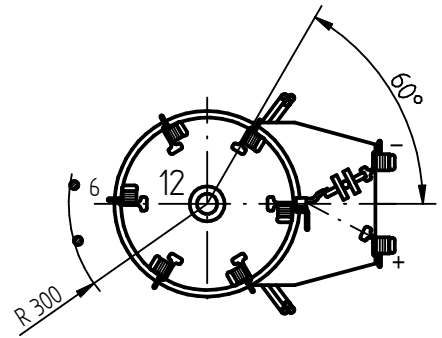
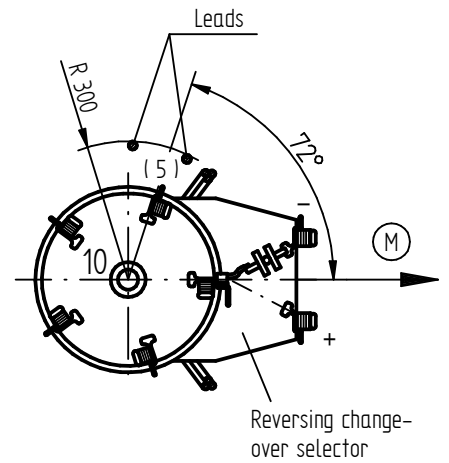

Without tie-in switch for max. 8 resistor elements per phase (as shown)

Potential of the on-load tap-changer take-off terminal

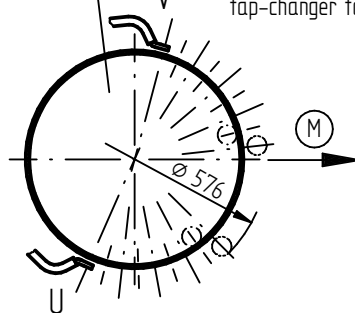

(M) - Drive side of selector

The connection diagram of the on-load tap-changer is binding for the designation of the terminals and phases.

DATE	NAME	DOCUMENT NO.
23.03.2016	RAEDLINGER	SED 1050465 001 03
CHKO. 11.04.2016	MENZELS	CHANGE NO.
STAND. 11.04.2016	PRODASTSCHUK	1073378
		SCALE 1:8

DIMENSION IN mm EXCEPT AS NOTED



ON-LOAD TAP-CHANGER OILTAP® MS AND VACUTAP® VM®  
 MS II / VM II 302 - SELECTOR SIZE B  
 TIE-IN RESISTORS WITHOUT TIE-IN SWITCH

SERIAL NUMBER

MATERIAL NUMBER 8986944E

SHEET 1/1

© MASCHINENFABRIK REINHAUSEN GMBH 2016  
 THE REPRODUCTION, DISTRIBUTION AND UTILIZATION OF THIS DOCUMENT AS WELL AS THE COMMUNICATION OF ITS CONTENTS TO OTHERS WITHOUT EXPRESS AUTHORIZATION IS PROHIBITED. OFFENDERS WILL BE HELD LIABLE FOR THE PAYMENT OF DAMAGES. ALL RIGHTS RESERVED IN THE EVENT OF THE GRANT OF A PATENT, UTILITY MODEL OR DESIGN.

DATE	NAME	DOCUMENT NO.
22.03.2016	RAEDLINGER	SED 1050463 001 03
CHKO. 11.04.2016	MENZELS	CHANGE NO.
STAND. 11.04.2016	PRODASTSCHUK	1073378
		SCALE
		1:8

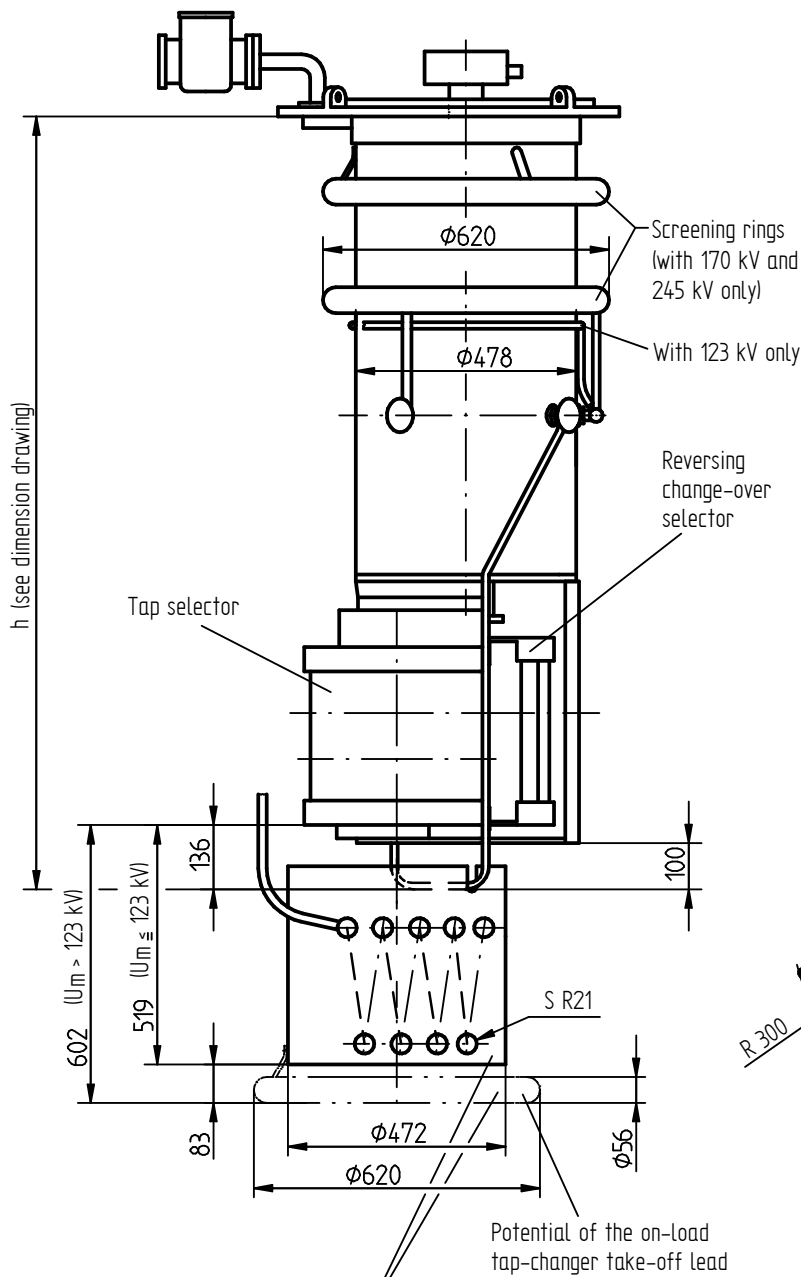

Arrangement of leads tie-in resistor - selector  
 For contact location see relevant dimension drawing

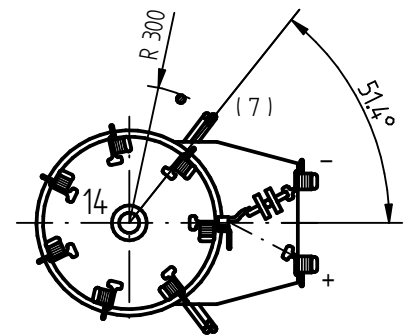
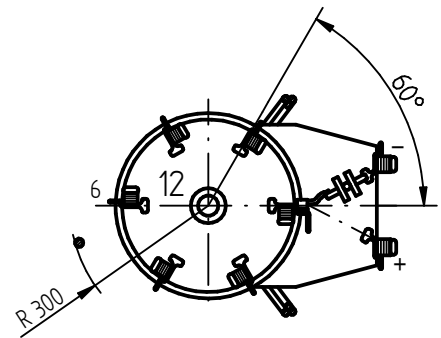
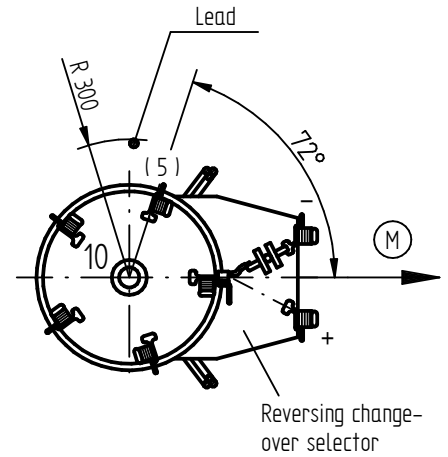

Without tie-in switch for max. 8 resistor elements (as shown)

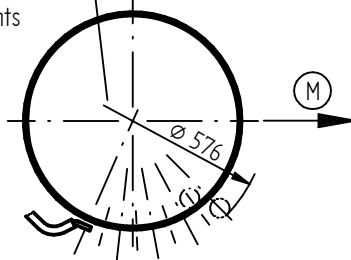

(M) - Drive side of selector

The connection diagram of the on-load tap-changer is binding for the designation of the terminals.

DIMENSION IN mm EXCEPT AS NOTED



ON-LOAD TAP-CHANGER OILTAP® MS AND VACUTAP® VM®  
 MS I / VM I 301 - SELECTOR SIZE B  
 TIE-IN RESISTORS WITHOUT TIE-IN SWITCH

SERIAL NUMBER

MATERIAL NUMBER  
 8986934E

SHEET  
 1/1

## 4.6 Электрические схемы (примеры)

Ниже представлены примеры электрических схем.

Электрическая схема в соответствии с заказом входит в комплект поставки.

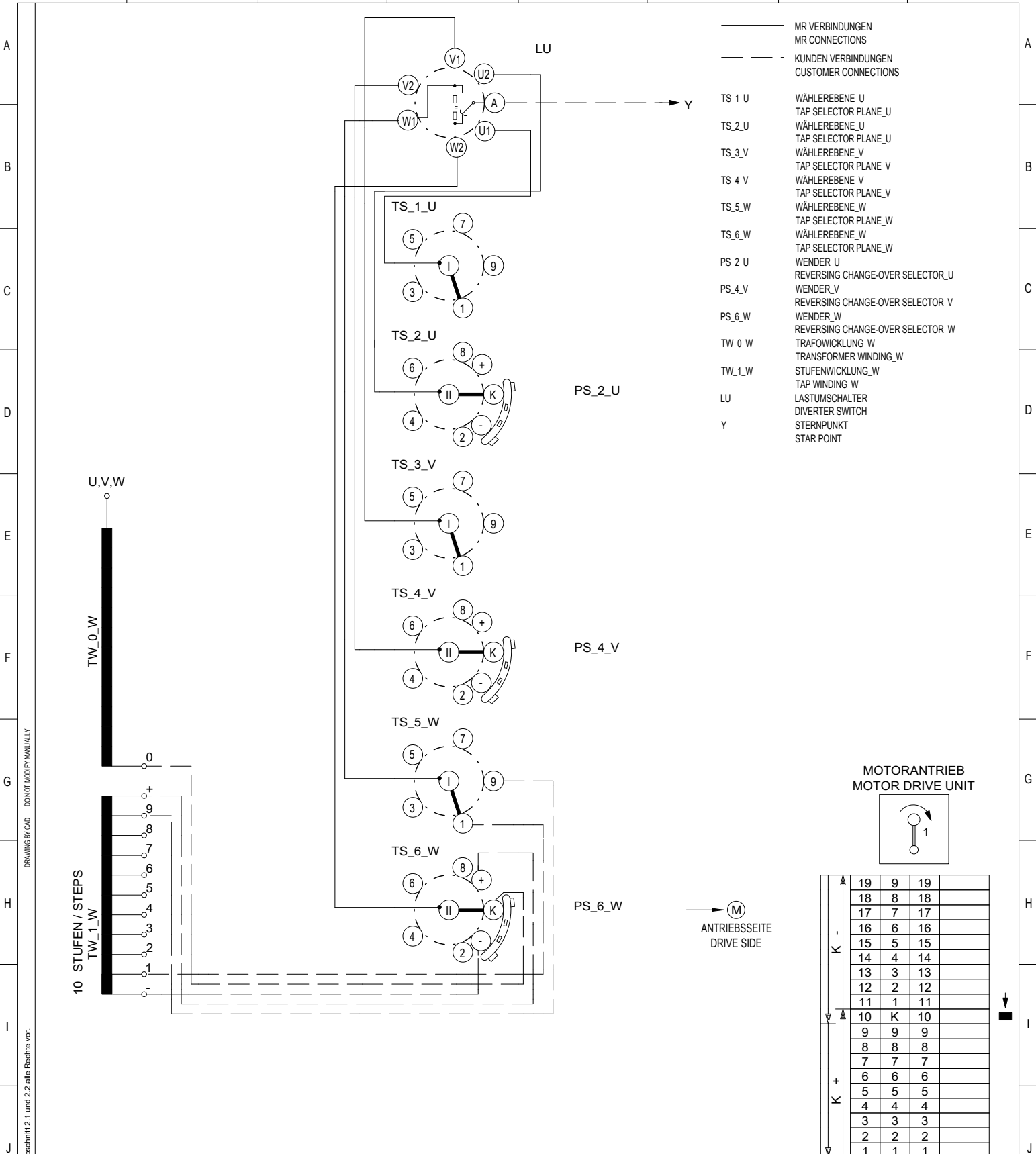

DRAWING BY CAD - DO NOT MODIFY MANUALLY

Für diese technische Unterlage behalten wir uns gemäss DIN 34 Abschnitt 2.1 und 2.2 alle Rechte vor.

BETRIEBSSTELLUNGEN SERVICE POSITIONS	19
VERSCHIEDENE SPANNUNGEN DIFFERENT VOLTAGES	19
JUSTIERSTELLUNG ADJUSTMENT POSITION	10

STELLUNG DES WENDERS POSITION OF REVERSING CHANGE-OVER SELECTOR	19
BETRIEBSSTELLUNG SERVICE POSITION	19
BEZEICHNUNG DER WÄHLERKONTAKTE DESIGNATION OF TAP SELECTOR CONTACTS	19
BEZEICHNUNG DER STELLUNGEN DESIGNATION OF POSITIONS	19
REGELBEREICH (kV) REGULATION RANGE (kV)	10

K -	19	9	19
	18	8	18
	17	7	17
	16	6	16
	15	5	15
	14	4	14
	13	3	13
	12	2	12
	11	1	11
	10	K	10
	9	9	9
	8	8	8
	7	7	7
	6	6	6
	5	5	5
	4	4	4
	3	3	3
	2	2	2
	1	1	1
K +			

→ (M) ANTRIEBSSEITE  
DRIVE SIDE

**LASTSTUFENSCHALTER VACUTAP® VM III 650Y-123/C-10 19 1W**  
**ON-LOAD TAP-CHANGER**

NO.	MODIFICATION	DATE	NAME

DATE	07.08.2018
ERIC	KONFIG
VERIFIED	CSO
STANDARD	

SCHALTBILD  
CONNECTION DIAGRAM

LANGUAGE:	DE
EN	
PROJECT:	2414658_01

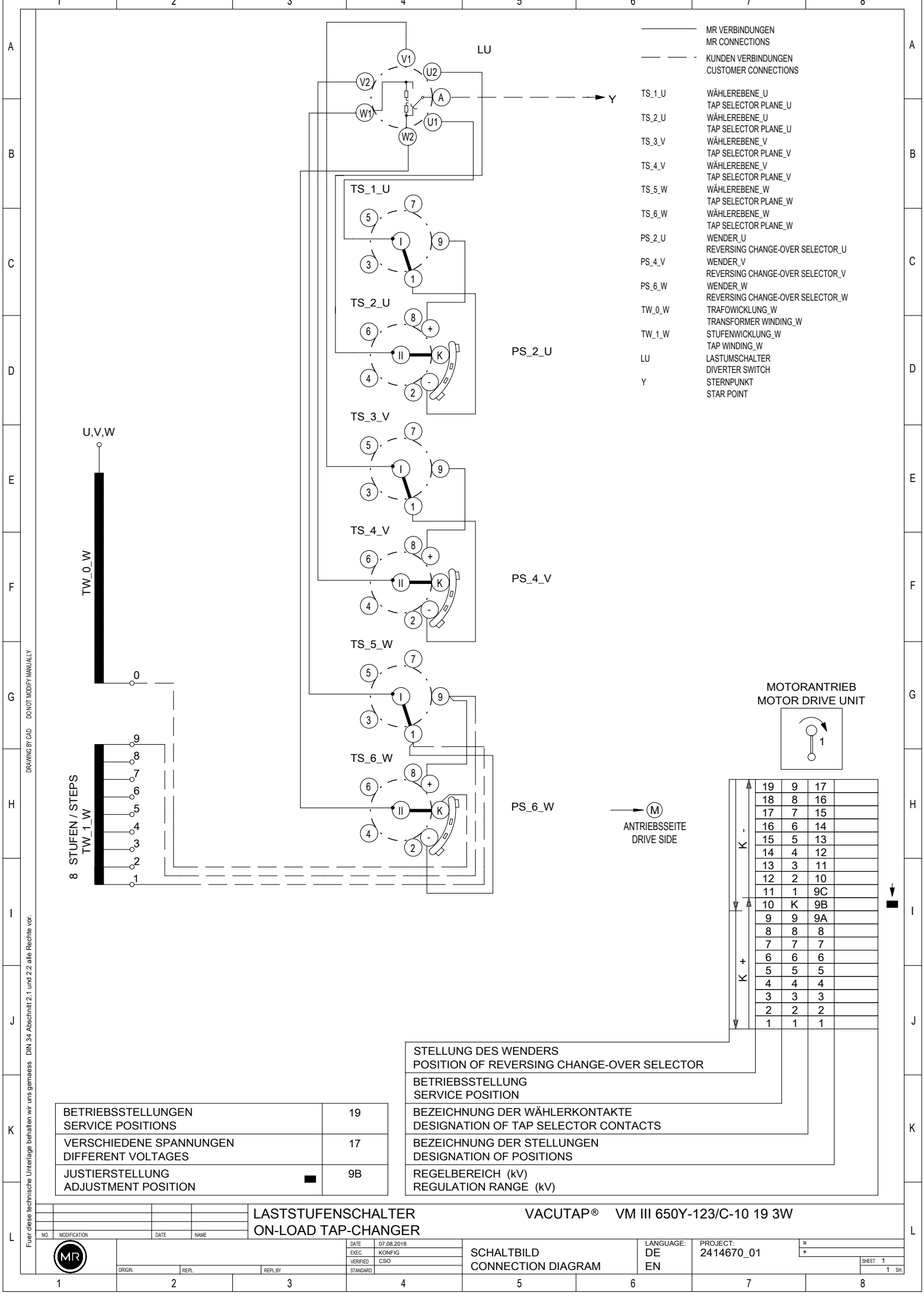

- MR VERBINDUNGEN  
MR CONNECTIONS
- KUNDEN VERBINDUNGEN  
CUSTOMER CONNECTIONS
- TS\_1\_U WÄHLEREBENE\_U  
TAP SELECTOR PLANE\_U
- TS\_2\_U WÄHLEREBENE\_U  
TAP SELECTOR PLANE\_U
- TS\_3\_V WÄHLEREBENE\_V  
TAP SELECTOR PLANE\_V
- TS\_4\_V WÄHLEREBENE\_V  
TAP SELECTOR PLANE\_V
- TS\_5\_W WÄHLEREBENE\_W  
TAP SELECTOR PLANE\_W
- TS\_6\_W WÄHLEREBENE\_W  
TAP SELECTOR PLANE\_W
- PS\_2\_U WENDER\_U  
REVERSING CHANGE-OVER SELECTOR\_U
- PS\_4\_V WENDER\_V  
REVERSING CHANGE-OVER SELECTOR\_V
- PS\_6\_W WENDER\_W  
REVERSING CHANGE-OVER SELECTOR\_W
- TW\_0\_W TRAFOWICKLUNG\_W  
TRANSFORMER WINDING\_W
- TW\_1\_W STUFENWICKLUNG\_W  
TAP WINDING\_W
- LU LASTUMSCHALTER  
DIVERTER SWITCH
- Y STERNPUNKT  
STAR POINT



MOTORANTRIEB  
MOTOR DRIVE UNIT

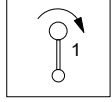

→ (M)  
ANTRIEBSSEITE  
DRIVE SIDE

19	9	17	
18	8	16	
17	7	15	
16	6	14	
15	5	13	
14	4	12	
13	3	11	
12	2	10	
11	1	9C	
10	K	9B	
9	9	9A	
8	8	8	
7	7	7	
6	6	6	
5	5	5	
4	4	4	
3	3	3	
2	2	2	
1	1	1	

STELLUNG DES WENDERS  
POSITION OF REVERSING CHANGE-OVER SELECTOR

BETRIEBSSTELLUNG  
SERVICE POSITION

BEZEICHNUNG DER WÄHLERKONTAKTE  
DESIGNATION OF TAP SELECTOR CONTACTS

BEZEICHNUNG DER STELLUNGEN  
DESIGNATION OF POSITIONS

REGELBEREICH (kV)  
REGULATION RANGE (kV)

BETRIEBSSTELLUNGEN SERVICE POSITIONS	19
VERSCHIEDENE SPANNUNGEN DIFFERENT VOLTAGES	17
JUSTIERSTELLUNG ADJUSTMENT POSITION	9B

LASTSTUFENSCHALTER VACUTAP® VM III 650Y-123/C-10 19 3W  
ON-LOAD TAP-CHANGER

NO.	MODIFICATION	DATE	NAME



DATE	07.08.2018
ERIC	KONFIG
VERIFIED	CSO
STANDARD	

SCHALTBILD  
CONNECTION DIAGRAM

LANGUAGE:  
DE  
EN

PROJECT:  
2414670\_01

FÜR DIESE TECHNISCHE UNTERLAGE BEHALTEN WIR UNS GEMÄSS DIN 34 ABSCHNITT 2.1 UND 2.2 ALLE RECHTE VOR.  
 DRAWING BY CAD DO NOT MODIFY MANUALLY

**ACHTUNG**  
 PARALLELBRÜCKEN VON MR NICHT ANGEBAUT  
 VON TS\_1 (PS\_1) NACH TS\_2 (PS\_2)  
 VON TS\_3 NACH TS\_4

**ATTENTION !**  
 PARALLEL BRIDGES ARE NOT INSTALLED BY MR  
 FROM TS\_1 (PS\_1) TO TS\_2 (PS\_2)  
 FROM TS\_3 TO TS\_4

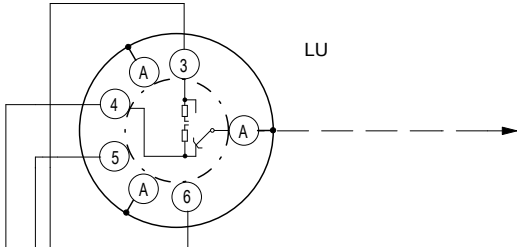

- MR VERBINDUNGEN  
MR CONNECTIONS
- - - KUNDEN VERBINDUNGEN  
CUSTOMER CONNECTIONS
- TS\_1 WÄHLEREBENE  
TAP SELECTOR PLANE
- TS\_2 WÄHLEREBENE  
TAP SELECTOR PLANE
- TS\_3 WÄHLEREBENE  
TAP SELECTOR PLANE
- TS\_4 WÄHLEREBENE  
TAP SELECTOR PLANE
- PS\_1 GROBWÄHLER  
COARSE TAP SELECTOR
- PS\_2 GROBWÄHLER  
COARSE TAP SELECTOR
- TW\_0 TRAFOWICKLUNG  
TRANSFORMER WINDING
- TW\_1 STUFENWICKLUNG  
TAP WINDING
- LU LASTUMSCHALTER  
DIVERTER SWITCH

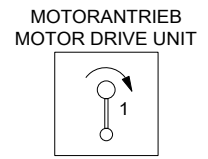
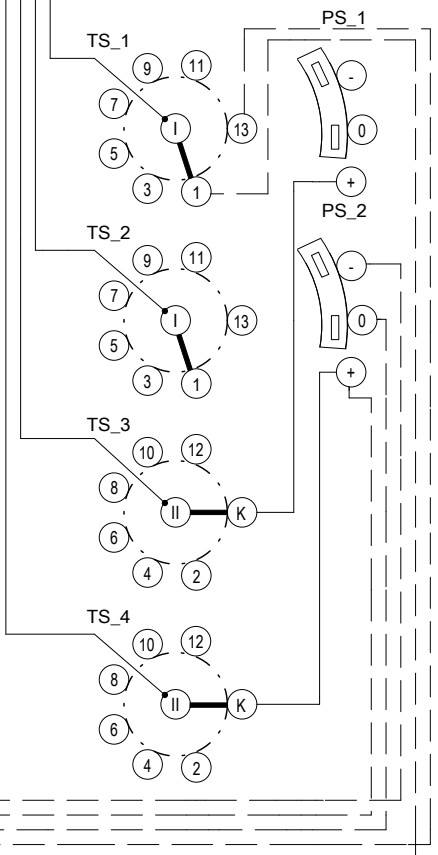
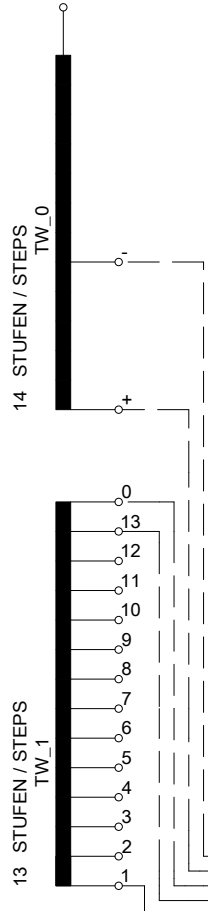

27	13	27	
26	12	26	
25	11	25	
24	10	24	
23	9	23	
22	8	22	
21	7	21	
20	6	20	
19	5	19	
18	4	18	
17	3	17	
16	2	16	
15	1	15	
14	K	14	
13	13	13	
12	12	12	
11	11	11	
10	10	10	
9	9	9	
8	8	8	
7	7	7	
6	6	6	
5	5	5	
4	4	4	
3	3	3	
2	2	2	
1	1	1	

➔ (M)  
 ANTRIEBSSEITE  
 DRIVE SIDE

STELLUNG DES GROBWÄHLERS POSITION OF COARSE TAP SELECTOR
BETRIEBSSTELLUNG SERVICE POSITION
BEZEICHNUNG DER WÄHLERKONTAKTE DESIGNATION OF TAP SELECTOR CONTACTS
BEZEICHNUNG DER STELLUNGEN DESIGNATION OF POSITIONS
REGELBEREICH (kV) REGULATION RANGE (kV)

BETRIEBSSTELLUNGEN SERVICE POSITIONS	27
VERSCHIEDENE SPANNUNGEN DIFFERENT VOLTAGES	27
JUSTIERSTELLUNG ADJUSTMENT POSITION	14

**LASTSTUFENSCHALTER VACUTAP® VM I 802-123/D-14 27 1G**  
**ON-LOAD TAP-CHANGER**

NO.	MODIFICATION	DATE	NAME



DATE	07.08.2018
ERIC	KONFIG
VERIFIED	CSO
STANDARD	

SCHALTBILD  
 CONNECTION DIAGRAM

LANGUAGE:  
 DE  
 EN

PROJECT:  
 2414631\_01

FÜR DIESE TECHNISCHE UNTERLAGE BEHALTEN WIR UNS GEMÄSS DIN 34 ABSCHNITT 2.1 UND 2.2 ALLE RECHTE VOR.  
 DRAWING BY CAD DO NOT MODIFY MANUALLY



- MR VERBINDUNGEN  
MR CONNECTIONS
- - - KUNDEN VERBINDUNGEN  
CUSTOMER CONNECTIONS
- TS\_1 - TS\_4 WÄHLEREBENEN  
TAP SELECTOR PLANES
- MS\_1 - MS\_4 MEHRFACHGROBWÄHLER  
MULTIPLE COARSE TAP SELECTOR
- TW\_0 TRAFOWICKLUNG  
TRANSFORMER WINDING
- TW\_1 STUFENWICKLUNG  
TAP WINDING
- LU LASTUMSCHALTER  
DIVERTER SWITCH

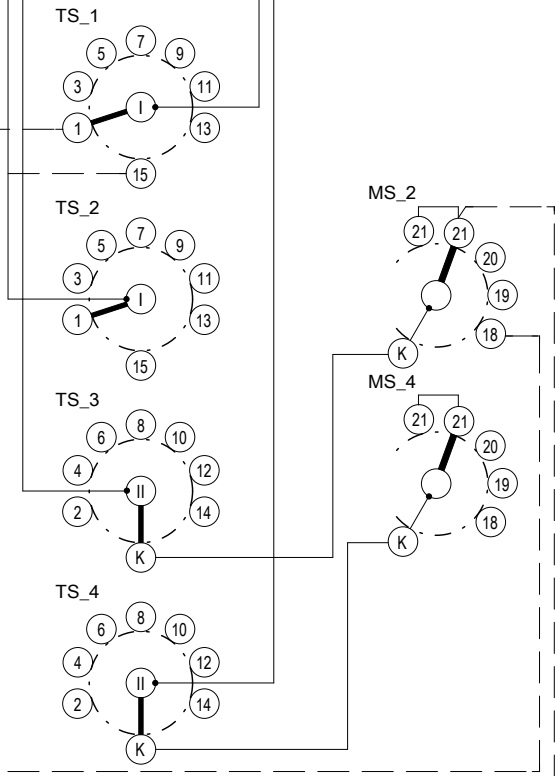
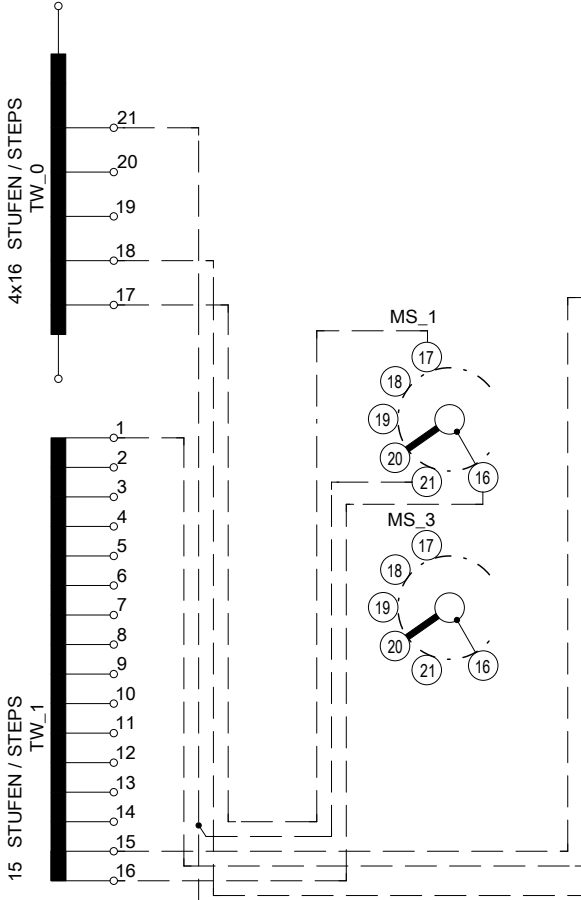
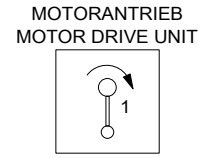
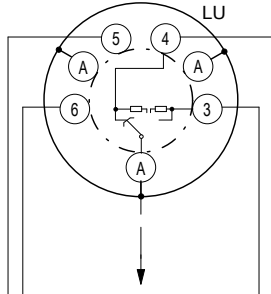

79	15	79
78	14	78
77	13	77
76	12	76
75	11	75
74	10	74
73	9	73
72	8	72
71	7	71
70	6	70
69	5	69
68	4	68
67	3	67
66	2	66
65	1	65
64	K	64
63	15	63
62	14	62
61	13	61
60	12	60
59	11	59
58	10	58
57	9	57
56	8	56
55	7	55
54	6	54
53	5	53
52	4	52
51	3	51
50	2	50
49	1	49
48	K	48
47	15	47
46	14	46
45	13	45
44	12	44
43	11	43
42	10	42
41	9	41
40	8	40
39	7	39
38	6	38
37	5	37
36	4	36
35	3	35
34	2	34
33	1	33
32	K	32
31	15	31
30	14	30
29	13	29
28	12	28
27	11	27
26	10	26
25	9	25
24	8	24
23	7	23
22	6	22
21	5	21
20	4	20
19	3	19
18	2	18
17	1	17
16	K	16
15	15	15
14	14	14
13	13	13
12	12	12
11	11	11
10	10	10
9	9	9
8	8	8
7	7	7
6	6	6
5	5	5
4	4	4
3	3	3
2	2	2
1	1	1

**ACHTUNG**  
PARALLELBÜCKEN VON MR NICHT ANGEBAUT  
VON TS\_1 NACH TS\_2  
VON TS\_3 NACH TS\_4  
VON MS\_1 NACH MS\_3  
VON MS\_2 NACH MS\_4

**ATTENTION !**  
PARALLEL BRIDGES ARE NOT INSTALLED BY MR  
FROM TS\_1 TO TS\_2  
FROM TS\_3 TO TS\_4  
FROM MS\_1 TO MS\_3  
FROM MS\_2 TO MS\_4

BETRIEBSSTELLUNGEN SERVICE POSITIONS	79
VERSCHIEDENE SPANNUNGEN DIFFERENT VOLTAGES	79
JUSTIERSTELLUNG ADJUSTMENT POSITION	16

ANTRIEBSSEITE  
DRIVE SIDE

STELLUNG DES GROBWÄHLERS  
POSITION OF COARSE TAP SELECTOR

BETRIEBSSTELLUNG  
SERVICE POSITION

BEZEICHNUNG DER WÄHLERKONTAKTE  
DESIGNATION OF TAP SELECTOR CONTACTS

BEZEICHNUNG DER STELLUNGEN  
DESIGNATION OF POSITIONS

**LASTSTUFENSCHALTER VACUTAP® VM I 802-123/C-16 79 1G**  
**ON-LOAD TAP-CHANGER**

NO.	MODIFICATION	DATE	NAME

ORIGIN	REPL.	REPL BY

DATE	07.08.2018
ERIC	KONFIG
VERIFIED	CSO
STANDARD	

SCHALTBILD  
CONNECTION DIAGRAM

LANGUAGE:	DE
EN	
PROJECT:	2407535_01

**ACHTUNG**  
 PARALLELBRÜCKEN VON MR NICHT ANGEBAUT  
 VON TS\_1 (PS\_1) NACH TS\_2 (PS\_2) NACH TS\_3 (PS\_3)  
 VON TS\_4 NACH TS\_5 NACH TS\_6

**ATTENTION !**  
 PARALLEL BRIDGES ARE NOT INSTALLED BY MR  
 FROM TS\_1 (PS\_1) TO TS\_2 (PS\_2) TO TS\_3 (PS\_3)  
 FROM TS\_4 TO TS\_5 TO TS\_6

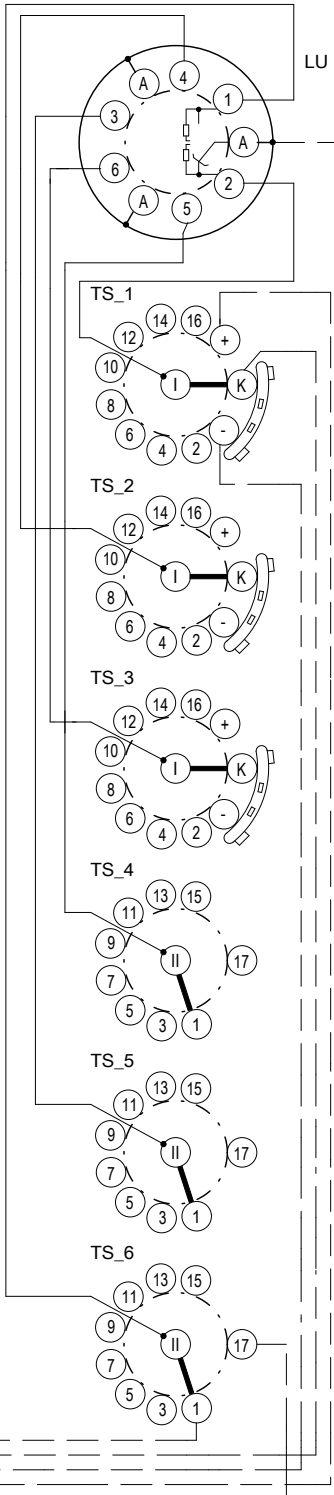

- MR VERBINDUNGEN  
MR CONNECTIONS
- KUNDEN VERBINDUNGEN  
CUSTOMER CONNECTIONS
- TS\_1 WÄHLEREbene  
TAP SELECTOR PLANE
- TS\_2 WÄHLEREbene  
TAP SELECTOR PLANE
- TS\_3 WÄHLEREbene  
TAP SELECTOR PLANE
- TS\_4 WÄHLEREbene  
TAP SELECTOR PLANE
- TS\_5 WÄHLEREbene  
TAP SELECTOR PLANE
- TS\_6 WÄHLEREbene  
TAP SELECTOR PLANE
- PS\_1 WENDER  
REVERSING CHANGE-OVER SELECTOR
- PS\_2 WENDER  
REVERSING CHANGE-OVER SELECTOR
- PS\_3 WENDER  
REVERSING CHANGE-OVER SELECTOR
- TW\_0 TRAFOWICKLUNG  
TRANSFORMER WINDING
- TW\_1 STUFENWICKLUNG  
TAP WINDING
- LU LASTUMSCHALTER  
DIVERTER SWITCH

**MOTORANTRIEB**  
**MOTOR DRIVE UNIT**

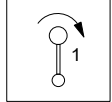

35	17	35
34	16	34
33	15	33
32	14	32
31	13	31
30	12	30
29	11	29
28	10	28
27	9	27
26	8	26
25	7	25
24	6	24
23	5	23
22	4	22
21	3	21
20	2	20
19	1	19
18	K	18
17	17	17
16	16	16
15	15	15
14	14	14
13	13	13
12	12	12
11	11	11
10	10	10
9	9	9
8	8	8
7	7	7
6	6	6
5	5	5
4	4	4
3	3	3
2	2	2
1	1	1

(M)  
 ANTRIEBSSEITE  
 DRIVE SIDE

STELLUNG DES WENDERS  
 POSITION OF REVERSING CHANGE-OVER SELECTOR

BETRIEBSSTELLUNG  
 SERVICE POSITION

BEZEICHNUNG DER WÄHLERKONTAKTE  
 DESIGNATION OF TAP SELECTOR CONTACTS

BEZEICHNUNG DER STELLUNGEN  
 DESIGNATION OF POSITIONS

REGELBEREICH (kV)  
 REGULATION RANGE (kV)

BETRIEBSSTELLUNGEN SERVICE POSITIONS	35
VERSCHIEDENE SPANNUNGEN DIFFERENT VOLTAGES	35
JUSTIERSTELLUNG ADJUSTMENT POSITION	18

**LASTSTUFENSCHALTER** VACUTAP® VM I 1203-123/C-18 35 1W  
**ON-LOAD TAP-CHANGER**

SCHALTBILD  
 CONNECTION DIAGRAM

LANGUAGE:  
 DE PROJECT: 2414636\_01  
 EN

FÜR DIESE TECHNISCHE UNTERLAGE BEHALTEN WIR UNS GEMÄSS DIN 34 ABSCHNITT 2.1 UND 2.2 ALLE RECHTE VOR.  
 DRAWING BY CAD DO NOT MODIFY MANUALLY



NO.	MODIFICATION	DATE	NAME

DATE	07.08.2018
EXEC.	KONFIG
VERIFIED	CSO
STANDARD	

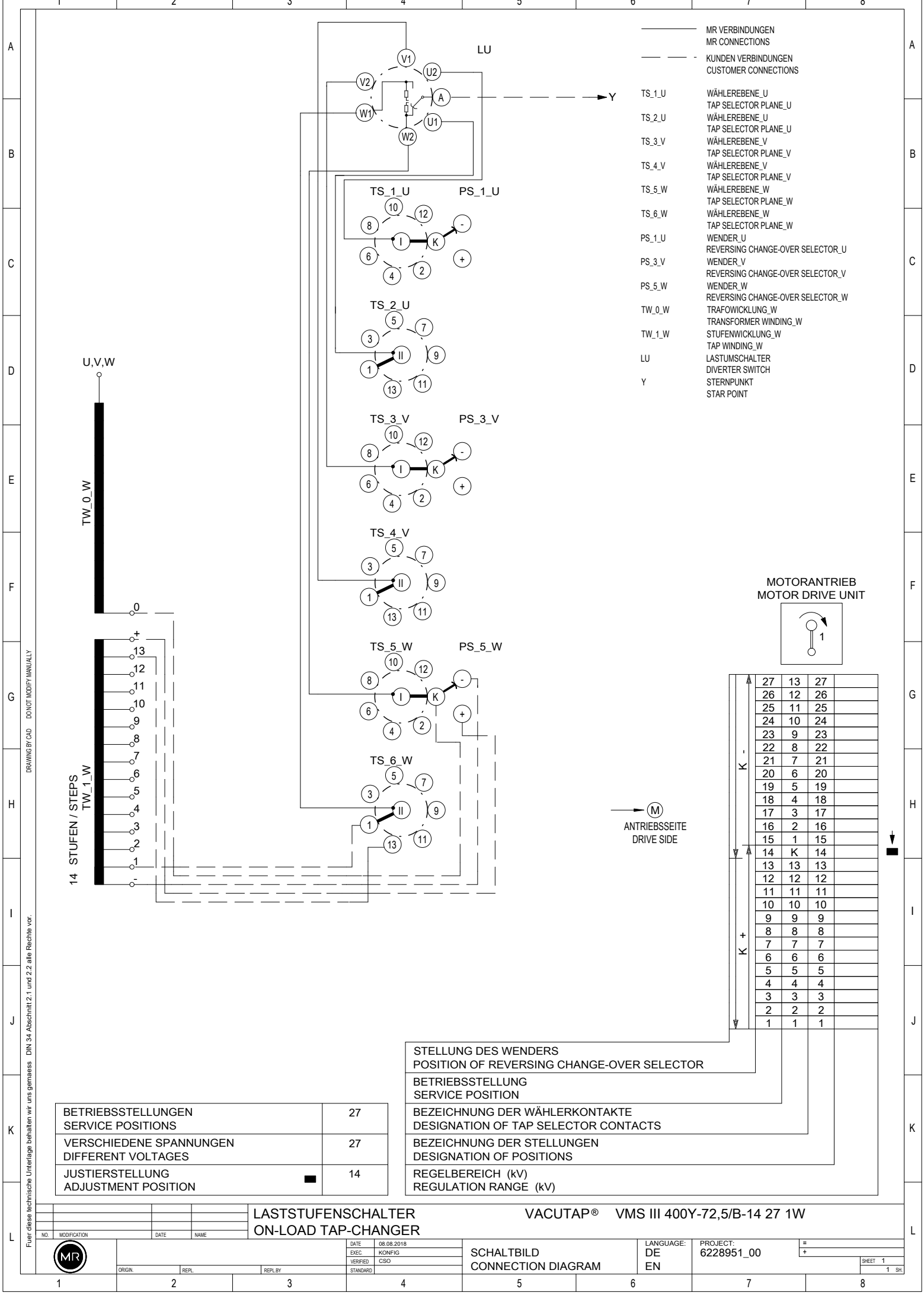

- MR VERBINDUNGEN  
MR CONNECTIONS
- - - KUNDEN VERBINDUNGEN  
CUSTOMER CONNECTIONS
- TS\_1\_U WÄHLEREbene\_U  
TAP SELECTOR PLANE\_U
- TS\_2\_U WÄHLEREbene\_U  
TAP SELECTOR PLANE\_U
- TS\_3\_V WÄHLEREbene\_V  
TAP SELECTOR PLANE\_V
- TS\_4\_V WÄHLEREbene\_V  
TAP SELECTOR PLANE\_V
- TS\_5\_W WÄHLEREbene\_W  
TAP SELECTOR PLANE\_W
- TS\_6\_W WÄHLEREbene\_W  
TAP SELECTOR PLANE\_W
- PS\_1\_U WENDER\_U  
REVERSING CHANGE-OVER SELECTOR\_U
- PS\_3\_V WENDER\_V  
REVERSING CHANGE-OVER SELECTOR\_V
- PS\_5\_W WENDER\_W  
REVERSING CHANGE-OVER SELECTOR\_W
- TW\_0\_W TRAFOWICKLUNG\_W  
TRANSFORMER WINDING\_W
- TW\_1\_W STUFENWICKLUNG\_W  
TAP WINDING\_W
- LU LASTUMSCHALTER  
DIVERTER SWITCH
- Y STERNPUNKT  
STAR POINT

**MOTORANTRIEB  
MOTOR DRIVE UNIT**

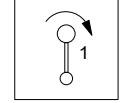

27	13	27	
26	12	26	
25	11	25	
24	10	24	
23	9	23	
22	8	22	
21	7	21	
20	6	20	
19	5	19	
18	4	18	
17	3	17	
16	2	16	
15	1	15	
14	K	14	
13	13	13	
12	12	12	
11	11	11	
10	10	10	
9	9	9	
8	8	8	
7	7	7	
6	6	6	
5	5	5	
4	4	4	
3	3	3	
2	2	2	
1	1	1	

→ (M)  
ANTRIEBSSEITE  
DRIVE SIDE

STELLUNG DES WENDERS  
POSITION OF REVERSING CHANGE-OVER SELECTOR

BETRIEBSSTELLUNG  
SERVICE POSITION

BEZEICHNUNG DER WÄHLERKONTAKTE  
DESIGNATION OF TAP SELECTOR CONTACTS

BEZEICHNUNG DER STELLUNGEN  
DESIGNATION OF POSITIONS

REGELBEREICH (kV)  
REGULATION RANGE (kV)

BETRIEBSSTELLUNGEN SERVICE POSITIONS	27
VERSCHIEDENE SPANNUNGEN DIFFERENT VOLTAGES	27
JUSTIERSTELLUNG ADJUSTMENT POSITION	14

**LASTSTUFENSCHALTER VACUTAP® VMS III 400Y-72,5/B-14 27 1W**  
**ON-LOAD TAP-CHANGER**

FÜR DIESE TECHNISCHE UNTERLAGE BEHALTEN WIR UNS GEMÄSS DIN 34 ABSCHNITT 2.1 UND 2.2 ALLE RECHTE VOR.  
 DRAWING BY CAD DO NOT MODIFY MANUALLY

- MR VERBINDUNGEN  
MR CONNECTIONS
- KUNDEN VERBINDUNGEN  
CUSTOMER CONNECTIONS
- TS\_1 WÄHLEREbene  
TAP SELECTOR PLANE
- TS\_2 WÄHLEREbene  
TAP SELECTOR PLANE
- TS\_3 WÄHLEREbene  
TAP SELECTOR PLANE
- TS\_4 WÄHLEREbene  
TAP SELECTOR PLANE
- TS\_5 WÄHLEREbene  
TAP SELECTOR PLANE
- TS\_6 WÄHLEREbene  
TAP SELECTOR PLANE
- PS\_2 WENDER  
REVERSING CHANGE-OVER SELECTOR
- PS\_4 WENDER  
REVERSING CHANGE-OVER SELECTOR
- PS\_6 WENDER  
REVERSING CHANGE-OVER SELECTOR
- TW\_0 TRAFOWICKLUNG  
TRANSFORMER WINDING
- TW\_1 STUFENWICKLUNG  
TAP WINDING
- LU LASTUMSCHALTER  
DIVERTER SWITCH
- Y STERNPUNKT  
STAR POINT

MOTORANTRIEB  
MOTOR DRIVE UNIT

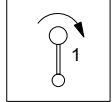

35	17	35
34	16	34
33	15	33
32	14	32
31	13	31
30	12	30
29	11	29
28	10	28
27	9	27
26	8	26
25	7	25
24	6	24
23	5	23
22	4	22
21	3	21
20	2	20
19	1	19
18	K	18
17	17	17
16	16	16
15	15	15
14	14	14
13	13	13
12	12	12
11	11	11
10	10	10
9	9	9
8	8	8
7	7	7
6	6	6
5	5	5
4	4	4
3	3	3
2	2	2
1	1	1

(M)  
ANTRIEBSSEITE  
DRIVE SIDE

STELLUNG DES WENDERS  
POSITION OF REVERSING CHANGE-OVER SELECTOR

BETRIEBSSTELLUNG  
SERVICE POSITION

BEZEICHNUNG DER WÄHLERKONTAKTE  
DESIGNATION OF TAP SELECTOR CONTACTS

BEZEICHNUNG DER STELLUNGEN  
DESIGNATION OF POSITIONS

REGELBEREICH (kV)  
REGULATION RANGE (kV)

BETRIEBSSTELLUNGEN SERVICE POSITIONS	35
VERSCHIEDENE SPANNUNGEN DIFFERENT VOLTAGES	35
JUSTIERSTELLUNG ADJUSTMENT POSITION	18

LASTSTUFENSCHALTER VACUTAP® VMS III 400Y-123/C-18 35 1W  
ON-LOAD TAP-CHANGER

FÜR DIESE TECHNISCHE UNTERLAGE BEHALTEN WIR UNS GEMÄSS DIN 34 ABSCHNITT 2.1 UND 2.2 ALLE RECHTE VOR.  
 DRAWING BY CAD DO NOT MODIFY MANUALLY

NO.	MODIFICATION	DATE	NAME

DATE	08.08.2018
ERIC	KONFIG
VERIFIED	CSO
STANDARD	

ORIGIN	REPL	REPL BY

SCHALTBILD  
CONNECTION DIAGRAM

LANGUAGE:  
DE  
EN

PROJECT:  
6228952\_00



## **Maschinenfabrik Reinhausen GmbH**

Falkensteinstrasse 8  
93059 Regensburg  
Germany  
+49 941 4090-0  
info@reinhausen.com  
[reinhausen.com](https://www.reinhausen.com)

**Please note:**

The data in our publications may differ from the data of the devices delivered.  
We reserve the right to make changes without notice.  
2332907/06 RU - VACUTAP<sup>®</sup> VM<sup>®</sup>, VM 300, VMS<sup>®</sup> Технические характеристики -  
F0248906 - 07/23  
Maschinenfabrik Reinhausen GmbH 2023

THE POWER BEHIND POWER.